

三菱工業用ミシン部品カタログ

Industrial Sewing Machine Parts Catalog

Model LY2-3750

目次	CONTENTS	Page
A 本体関係	Arm bed & it's accessories	2
B 縫機構 (I)	Sewing mechanism (I)	4
C 縫機構 (II) および下送り機構	Sewing mechanism (II) & feed rock lower shaft mechanism	6
D 送り調節機構	Stitch length mechanism	8
E 上部水平送り機構	Upper feed rock shaft mechanism	10
F 上部上下送り機構	Upper feed lifting rock shaft mechanism	12
G 押え機構	Presser foot mechanism	14
H 糸切り機構	Knife actuating mechanism	16
J タッチバック機構および検出器機構	Touch back mechanism & detector mechanism	18
K 給油機構	Oil lubrication mechanism	20
L 付属品	Accessories	22
M 索引	Index	24

ミシン用部品コードの採番基準 MITSUBISHI SPARE PARTS No. Designation system

注：※欄には英文字(A,B,...X,Y,Z)が入る。
Remarks : Alphabet(A,B,...X,Y,Z) should be taken at ※ mark.

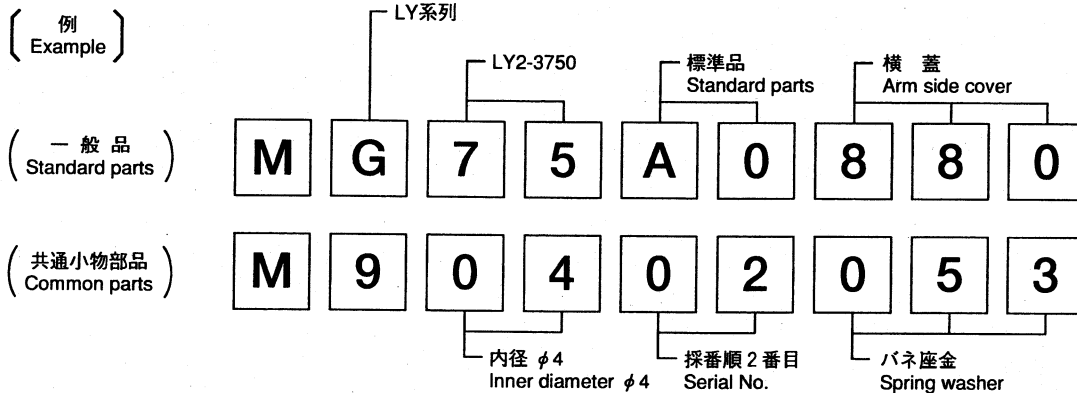
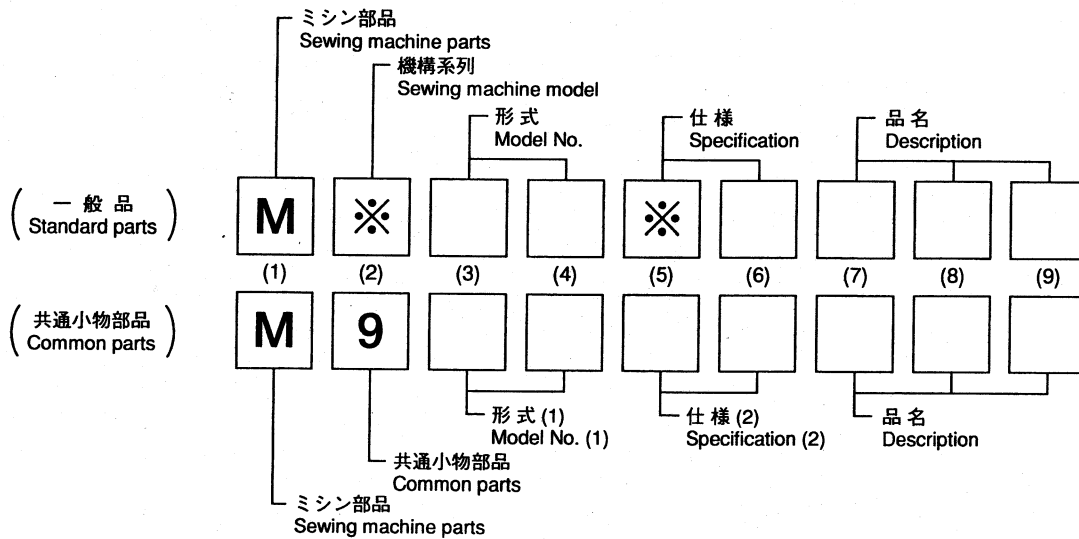

注：一般品についての機種形名は、その部品が最初に使用された機種形名を示します。従って長期に亘る場合は、機種の変更が行われるため、当初の機種以外の機種で使用されている場合があります。
Sewing machine Models, of Standard Parts are indicated model of these parts are registered firstly. Parts are used for not only the indicated model, but also another models, in reason of New development, improvement after.

パーツカタログご利用に際して Information on use of the parts catalog

- ・ 補用品ご注文の際は、部品コードでご注文下さい。また、このパーツブックの管理番号と発行年月（表紙右下、例えば、P-1...19908）モデル機械番号を、合わせてご連絡頂ければ幸いです。
- ・ 一部の部品について、改良のため予告なしに変更になる場合がありますのでご了承下さい。
- ・ このパーツカタログは1999年12月のデータにもとづいて作成されたものです。
- ・ 部品コード欄が、—となっている部品は、補給いたしません。ただし組コードが記載されているものは、組部品として補給いたしますので、組コードでご注文下さい。
- ・ 使用個数欄の英数字組合せ文字は、このモデル番号のサブ機械番号をしめしています。
- ・ 尚、本パーツブックの記載内容にお気付きの点がありましたら、お知らせ頂ければ幸いです。
- ・ When ordering any spare part, please specify its part code. In addition, please specify the management number and issued date of this parts catalog (e. g. P-1 ...199008 indicated at bottom right of the front cover) and the machine model number.
- ・ Some parts are subject to change due to modification without notice.
- ・ This parts catalog is based the data as of Dec.1999.
- ・ Any part marked-in the part code column will not be supplied. When a part has its assembly code, please specify the assembly code because that part is supplied as an assembly part.
- ・ Alphanumerical characters indicated in the required quantity column indicate the sub machine number of this model number.
- ・ Please write to us if you have any question on this parts catalog.

① 本体関係
 ARM BED & IT'S ACCESSORIES

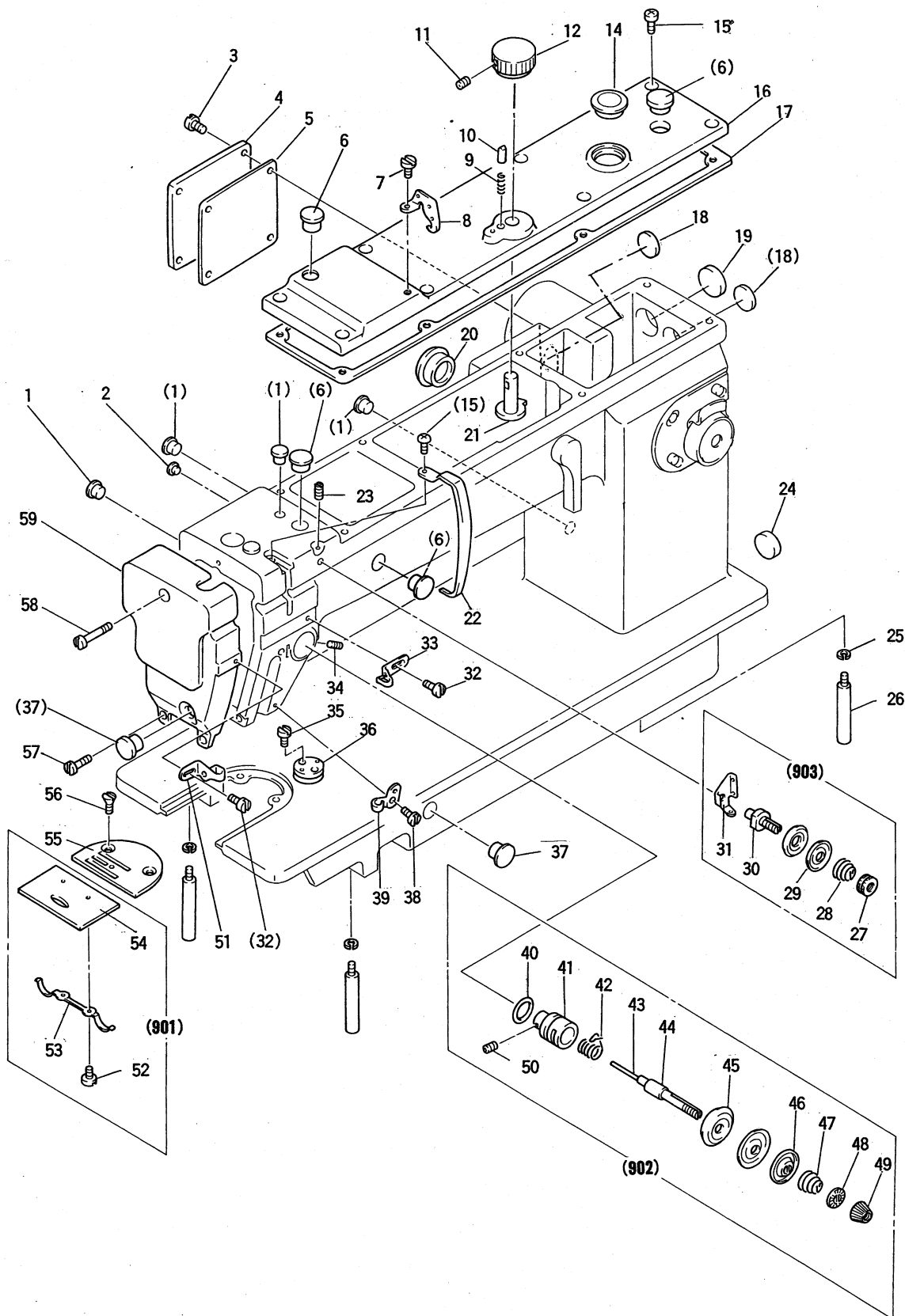

A 本体機構

ARM BED & IT'S ACCESSORIES

Fig. 変更 No.	部品コード Mod Parts.No.	部品名	Description	使用数 Amt. Reg.
A01	M90883080	ゴムセシ	Rubber plug ϕ 8.8	4
A02	M90573080	ゴムセシ	Rubber plug ϕ 5.7	1
A03	M91109004	サカネツキフライネシ	Screw 11/64(40)x8	4
A04	MG75A0880	ヨコフター1	Arm side cover-1	1
A05	MG75A0691	カスケツト	Gascket for arm side cover-1	1
A06	M91910080	ゴムセシ	Rubber plug ϕ 19	4
A07	M91109002	ヒラネシ	Screw 11/64(40)x7	1
A08	MG75A0180	イトアンナイ	Thread guide (arm top)	1
A09	MG75A0572	ツルマキハネ	Coil spring	1
A10	M90431060	ピン	Pin	1
A11	M91053020	ロツカクアナツキトメネシ	Socket set screw M4X6	2
A12	MG70A0631	ダイヤル	Dial	1
A14	MF20A0135	アフラムト	Oil check window	1
A15	M91106604	フライネシ	Screw 11/64(40)X8	9
A16	MG70A0600	トップカバー	Top cover	1
A17	MG75A1691	カスケツト	Gascket for top cover	1
A18	M92200080	セシ	Rubber plug ϕ 22	2
A19	M92900080	セシ	Rubber plug ϕ 29	1
A20	M92601080	セシ	Rubber plug ϕ 26	1
A21	MG75A0291	シヨウケオクリヨウセツカム	Upper feed lifting regulator cam	1
A22	MF03A0584	テンヒンカバー	Thread take-up cover	1
A23	M91108001	トメネシ	Set screw 11/64(40)x5.5	1
A24	M92701080	セシ	Rubber plug ϕ 27	1
A25	M90106053	ハネサカネ	Spring washer 6	3
A26	MF10A0151	サエ	Leg	3
A27	M91101046	ツマミナツト	Pre-tension adjusting nut 11/64(40)	1
A28	MF36A0245	エンスイハネ	Pre-tension spring	1
A29	MF10A1555	チヨウシサラ	Tension discs for pre-tension	2
A30	MF00A0553	チヨウシホウ	Pre-tension stud	1
A31	MF00A0181	イトアンナイ	Thread guide	1
A32	M90909003	マルヒラネシ	Screw 9/64(40)x6	2
A33	MG43A0181	イトアンナイ	Thread guide	1
A34	M91508001	トメネシ	Set screw 15/64(28)x6	1
A35	M91107002	ヒラネシ	Screw 11/64(40)x5.5	2
A36	MG30A0601	トリツカイタ	Cloth guide plate	1
A37	M91182080	セシ	Rubber plug ϕ 11.8	2
A38	M90906002	ヒラネシ	Screw 9/64(40)x4.5	1
A39	MQ50A0181	イトアンナイ	Thread guide	1
A40	M91501085	リング	O-ring S15	1
A41	MF10A0709	フツシユ	Thread tension regulator bushing	1
A42	MF02A0187	イトトリハネ	Thread take-up spring	1
A43	M90228060	ピン	Thread tension pin	1
A44	MF02A0553	チヨウシホウ	Thread tension stud	1
A45	MF10A0555	チヨウシサラ	Thread tension discs	2
A46	MM11A0556	チヨウシサラオサエ	Thread tension releasing disc	1
A47	MG52A0245	エンスイハネ	Thread tension spring	1
A48	MT60A0802	マワリトメ	Thumb nut revolution stopper	1
A49	M91605045	ツマミナツト	Thumb nut 1/4(40)	1
A50	M90901002	ヒラネシ	Screw 9/64(40)x4	1
A51	MG43A1181	イトアンナイ	Thread guide	1
A52	M90604002	ヒラネシ	Screw 3/32(56)x2.2	2
A53	MF10A0471	イタハネ	Spring for slide plate	1
A54	MG75A0470	スアリイタ	Slide plate	1
A55	MF26B0101	ハリイタ	Needle plate (B2.6)	1
A56	M91102011	マルサラネシ	Screw 11/64(40)x8.5	2
A57	M91106003	マルヒラネシ	Screw 11/64(40)x20	2
A58	M91070003	マルヒラネシ	Screw M4X30	1
A59	MG75A0830	メンイタ	Face plate	1
A901	MG75E0470	スアリイタクミタテ	Slide plate complete	1
A902	MG75E0210	チヨウセツキクミタテ	Thread tension regulator complete	1
A903	MF00E0550	イトチヨウセツキクミタテ	Pre-tension assy.	1

② 縫い機構(I)
SEWING MECHANISM (I)

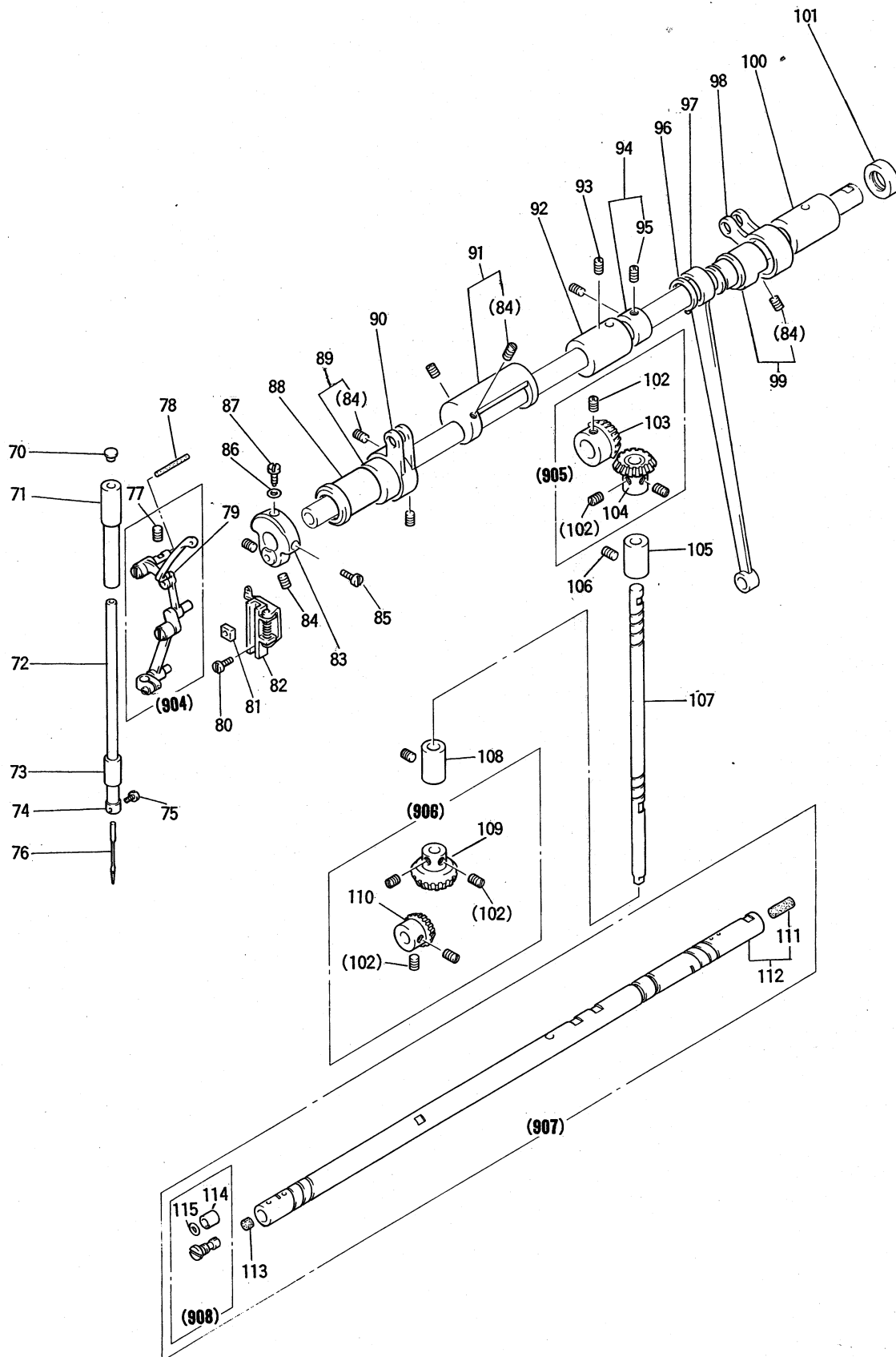

B 縫機構 (1)
SEWING MECHANISM (1)

Fig. 変更 部品コード				使用数	
No.	Mod	Parts.No.	部 品 名	Description	Amt. Reg.
B070		M90883080	ゴムセシ	Rubber plug ϕ 8.8	1
B071		MF60A0663	ハリホウメタルウエ	Needle bar bushing(upper)	1
B072		MG75A0660	ハリホウ	Needle bar	1
B073		MG75A0664	ハリホウメタルシタ	Needle bar bushing(lower)	1
B074		MG42A0181	イトアンナイ	Thread guide for needle bar	1
B075		M90815002	ヒラネジ	Screw 1/8(44)x4.5	1
B076		MG37A0128	ミシンハリ DPX17-22	Needle DPX17-22	1
B077		M91513001	トメネジ	Set screw 15/64(28)x10	1
B078		MF01A0740	フェルト	Felt	1
B079		MF03A0417	ゴムワ	Oil shade cap	1
B080		M91106004	フライネジ	Screw 11/64(40)x8	2
B081		MF10A0325	カクマ	Square block	1
B082		MG44E0662	ハリカイトクミタテ	Needle bar connecting link guide assy.	1
B083		MG75E0383	クランククミタテ	Crank assy.	1
B084		M91606001	トメネジ	Set screw 1/4(40)x6	8
B085		M91801002	ヒラネジ	Screw 9/32(28)x13	1
B086		M90700085	オリンク	O-ring 1AP7	1
B087		M91802006	ヒラネジホウサキ	Screw 9/32(28)x14	1
B088		MG75A0232	ウラシクメタルヒタリクミタテ	Bushing for arm shaft(left)	1
B089		MG75E0492	ハンシンリンクミタテ	Upper feed lifting cam	1
B090		MG75A0956	レンセツカン	Upper feed rock crank	1
B091		MG75E0693	ハランスウエイクミタテ	Balance weight	1
B092		MF05A0234	ウラシクメタルナカ	Upper shaft bushing (middle)	1
B093		M91506001	トメネジ	Set screw 15/64(28)x7	1
B094		MF80A0352	カラクミタテ	Collar for arm shaft assy.	1
B095		M91602001	トメネジ	Set screw 1/4(40)x4	2
B096		M90320065	Cタイプメウシクヨウ 20	C-type stop ling 20	1
B097		MG75A1956	レンセツカン	Crank rod	1
B098		MG75A2956	レンセツカン	Upper feed rock Crank	1
B099		MG75E1492	ハンシンリンクミタテ	Upper feed lifting cam	1
B100		MG75A0233	ウラシクメタルミキ	Upper shaft bushing(right)	1
B101		M91472086	オイルシール	Oil seal	1
B102		M91610001	トメネジ	Set screw 1/4(40)x7	8
B103		MF40A0331	ウラシクカサハクマルマ	Upper shaft gear	1
B104		MF40A0333	タテシクカサハクマルマウエ	Vertical shaft gear (upper)	1
B105		MG75A0521	タテシクメタルウエ	Vertical shaft bushing (upper)	1
B106		M91513001	トメネジ	Set screw 15/64(28)x9.5	2
B107		MG75A0520	タテシク	Vertical shaft	1
B108		MF74B0522	タテシクメタルシタ	Vertical shaft bushing (lower)	1
B109		MF40A0334	タテシクカサハクマルマシタ	Vertical shaft gear (lower)	1
B110		MF40A0332	シタシクカサハクマルマ	Lower shaft gear	1
B111		M90740080	ゴムセシ	Rubber plug	1
B112		MG75E0230	ウラシククミタテ	Arm shaft	1
B113		MF01A1740	フェルト	Felt	1
B114		MG75A0417	ゴムワ	Rubber bushing	1
B115		M90402085	オリンク	O-ring S4	1
B904		MG75E0580	テンビンハリクミタテ	Thread take-up lever assy.	1
B905		MF01E0331	カサハクマルマクミタテ	Bevel gear for arm shaft	1
B906		MF01E0332	カサハクマルマクミタテ	Bevel gear for arm shaft	1
B907		MG75E1230	ウラシククミタテ	Upper shaft assy.	1
B908		M907006060	キヨウチヨウセツピソクミタテ	Oil amount adjusting pin assy.	1

③ 縫機構 (II) および下送り機構
 SEWING MECHANISM (II) & FEED ROCK LOWER SHAFT
 MECHANISM

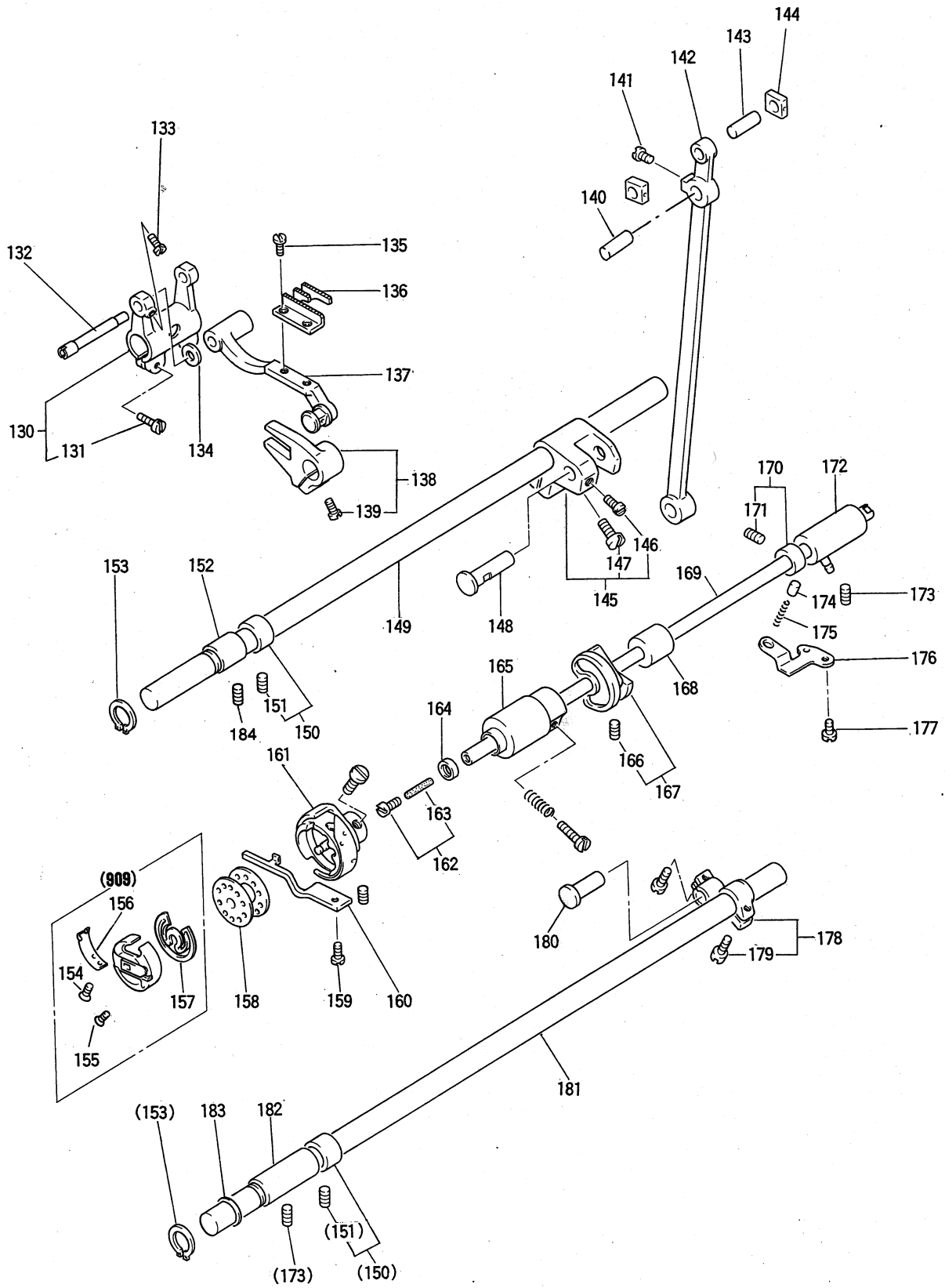

C 縫機構 (II) および下送り機構

SEWING MECHANISM (II) & FEED ROCK LOWER SHAFT MECHANISM

Fig. 変更 部品コード				使用数	
No.	Mod	Parts.No.	部品名	Amt. Reg.	
				BIT	
C130		MF90A0278	スライオクリウテヒタリクミタテ	Feed rock shaft crank(left)	1
C131		M91204003	マルヒラネジ	Screw 3/16(28)X12	2
C132		MF90A0283	ハンジシク	Shaft for feed bar (eccentric)	1
C133		M91106004	フライネジ	Screw 11/64(40)x8	1
C134		M90619050	サカネ	Washer	1
C135		M90806002	ヒラネジ	Screw 1/8(44)X6	2
C136		MG75A0104	オクリ	Feed dog B1.6	1
C137		MF00E0281	オクリクミタテ	Feed bar assy.	1
C138		MF01E0276	シヨウケオクリフタマクミタテ	Feed lifting rock shaft fork	1
C139		M91112002	ヒラネジ	Screw 11/64(40)X12	1
C140		MG75A0454	シク	Upper Feed rock shaft	1
C141		M91521002	ヒラネジ	Screw 11/64(40)x7	1
C142		MG75A3956	レンセツカン	Connecting rod for upper feed	1
C143		MG75A1454	シク	Upper feed rock shaft	1
C144		MN40A0325	カクコマ	Square block	2
C145		MG75E0279	スライオクリウテミキクミタテ	Feed rock shaft crank (right)	1
C146		M91516002	ヒラネジ	Screw 15/64(28)X8.5	1
C147		M91507002	ヒラネジ	Screw 15/64(28)X18	1
C148		M97013060	ツハツキシク	Pin	1
C149		MG75A0491	スライオクリシク	Feed rock shaft	1
C150		MF80A0352	カラクミタテ	Collar for arm shaft assy.	2
C151		M91602001	トメネジ	Set screw 1/4(40)x4	4
C152		MG75A0285	オクリシクメタル	Bushing for feed rock shaft (left)	1
C153		M90315065	カクタトメシクヨウ 15	C-type stop ling 15	2
C154		M97086030	イトチヨウシネジ	Tension regulating screw 3/32(100)X2.2	1
C155		M97088030	イトチヨウシハネトメネジ	Tension spring screw 1/16(80)X1.5	1
C156		MF03A0557	イトチヨウシハネ	Bobbin thread tension spring	1
C157		MF03A0245	クテンホウシハネ	Bobbin tension spring	1
C158		MF25B0123	ホヒン	Bobbin	1
C159		M91118002	ヒラネジ	Screw 11/64(40)x10	1
C160		MF20A0229	ウチカマトメ	Rotating hook positioner	1
C161		MG44B0120	カクミタテ KHS20-RMP	Rotating hook complete KHS20-RMP	1
C162		M91259030	トクシネジ	Special screw	1
C163		MF05A0740	フィルタ	Oil felter for lower shaft	1
C164		M90800086	オイルシール	Oil seal	1
C165		MF00A0451	シタシクメタルヒタリ	Lower shaft bushing(left)	1
C166		M91602020	ソケットアナツキトメネジ	Soket set screw 1/4(40)x10	2
C167		MF00A0350	イトキリカムクミタテ	Thread trimmer cam assy.	1
C168		MF00A0453	シタシクメタルナカ	Lower shaft bushing(middle)	1
C169		MG75A0450	シタシク	Lower shaft	1
C170		MF01E0352	カラクミタテ	Thrust collar assy.	1
C171		M91106001	トメネジ	Set screw 11/64(40)x3.7	2
C172		MG75A0452	シタシクメタルミキ	Lower shaft bushing(right)	1
C173		M91513001	トメネジ	Set screw 15/64(28)x9.5	2
C174		MF00A0753	プランジャ	Plunger	1
C175		MF00A0572	ツルマキハネ	Spring	1
C176		MF83A0154	アンナイタ	Guide plate	1
C177		M91515002	ヒラネジ	Screw 15/64(28)x10	1
C178		MF00A0277	シヨウケオクリウテミキクミタテ	Feed lifting rock shaft crank(right)assy.	1
C179		M91204003	マルヒラネジ	Screw 3/16(28)x12	2
C180		M90904060	ツハツキシク	Pin	1
C181		MG75A1460	シヨウケオクリシク	Feed lifting rock shaft	1
C182		MF70A0286	シヨウケオクリシクメタルヒタリ	Bushing for lifting rock shaft (left)	1
C183		M91502050	サカネ	Washer	1
C184		M91503001	トメネジ	Set screw 15/64(28)x4.5	1
C909		MG44E0125	ホヒンケース	Bobbin case complete	1

4 送り調節機構
 STITCH LENGTH MECHANISM

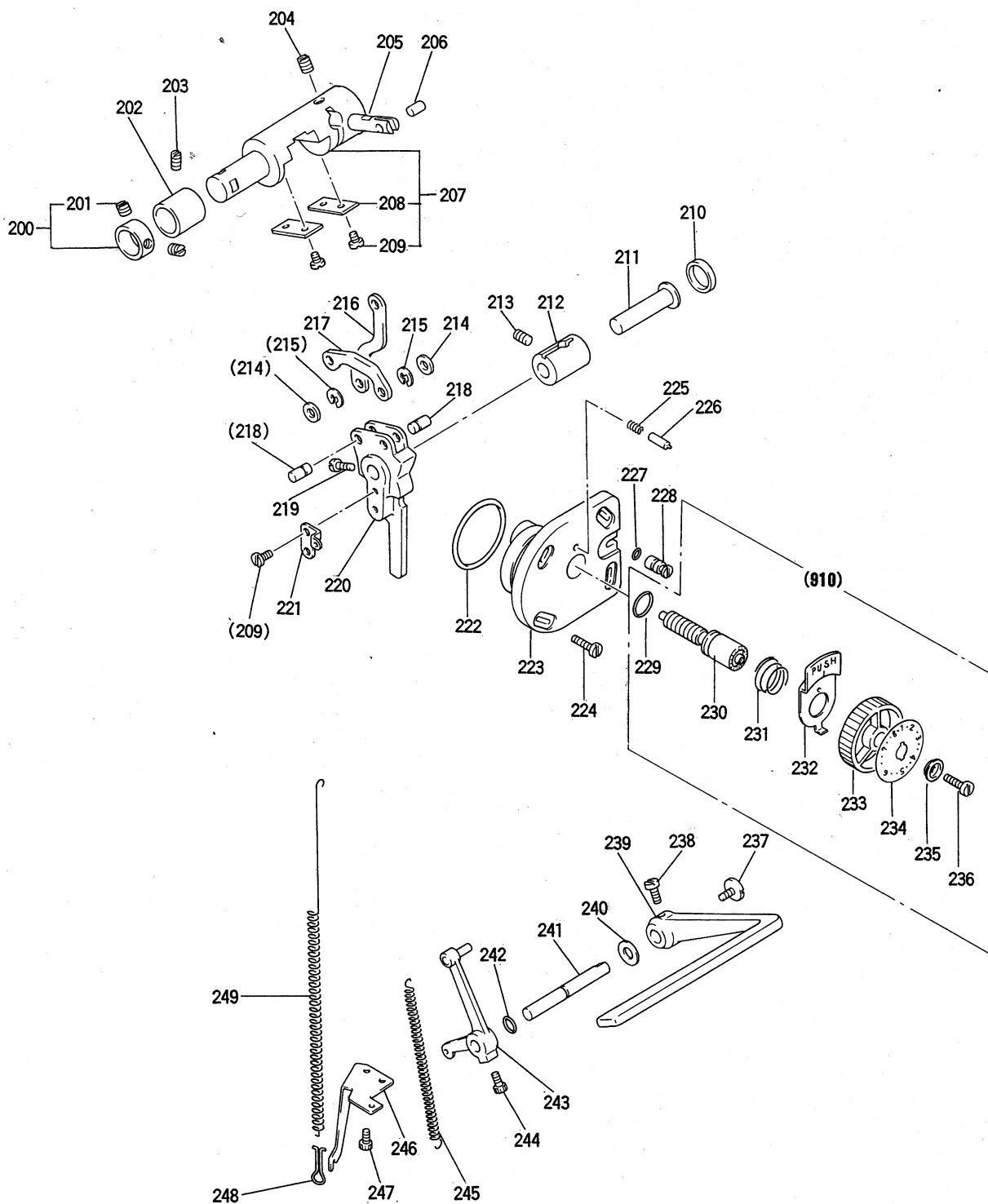

D 送り調節機構

STITCH LENGTH MECHANISM

Fig. No.	変更 Mod	部品コード Parts.No.	部品名	Description	使用数 Amt. Reg. BIT
D200		MF80A0352	カラークミタテ	Thrust collar assy.	1
D201		M91602001	トメネジ	Set screw 1/4(40)X4	2
D202		MG75A0285	オクリシメタル	Bushing	1
D203		M91108001	トメネジ	Set screw 11/64(40)X6	1
D204		M91513001	トメネジ	Set screw 15/64(28)X9.5	1
D205		MG75A0602	トリツツカネ	Bracket pin	1
D206		MG75A2454	シク	Pin	1
D207		MG75E0321	加工シヤクミタテ	Reverse bar complete	1
D208		MN45A0154	案内イタ	Guide plate	2
D209		M91106004	フマインシ	Screw 11/64(40)x8	6
D210		M92004080	ゴムセン	Rubber plug φ20	1
D211		M90904063	タンツクシク	Pin	1
D212		MF70A0750	フツシ	Bushing for feed regulator	1
D213		M91506001	トメネジ	Set screw 11/64(28)X6.5	1
D214		MG75A1476	スペーサ	Spacer	2
D215		M90504065	E型外メリ 4	E-type stop ring 4	2
D216		MG75A0910	リンク	Link	1
D217		MG75A1910	リンク	Link	1
D218		MG75A3454	シク	Pin	2
D219		M91516002	ヒラネジ	Screw 15/64(28)x8.5	1
D220		MG75A0152	オクリチヨウセツカム	Feed regulator	1
D221		MF00A2708	カケカネ	Spring holder	1
D222		M93600085	Oリング	O-ring S36	1
D223		MG75A0603	トリツツクタイ	Bracket	1
D224		M91118002	ヒラネジ	Screw 11/64(40)x10	4
D225		MF05A0572	ツルマキハネ	Spring	1
D226		MF00A0852	ピン	Pin	1
D227		M90700085	Oリング 1AP7	O-ring 1AP7	1
D228		MG75E0633	ヌイメチヨウセツシクミタテ	Feed regulator pin complete	1
D229		M91000085	Oリング 1AP10A	O-ring 1AP10A	1
D230		MF85A0640	オクリチヨウセツシ	Stitch length regulator screw	1
D231		MF02A0245	エンスイハネ	Coil spring	1
D232		MF00A0950	レバ	Releasing lever	1
D233		MG75A0631	ダイヤル	Dial	1
D234		MG75A0841	メモリイタ	Stitch length indicating plate	1
D235		MF00A0257	オサエカネ	Bushing	1
D236		M91215002	ヒラネジ	Screw 3/16(28)x12	1
D237		M91207003	マルヒラネジ	Screw 3/16(28)x6.5	1
D238		M91515002	ヒラネジ	Screw 15/64(28)x10	2
D239		MF01A0632	ヌイメカケンレバ	Feed reversing lever	1
D240		M95003053	ハネサカネ	Spring washer	1
D241		MF00A0633	ヌイメカケンシク	Feed reversing lever shaft	1
D242		M90600085	Oリング 1AP6	O-ring 1AP6	1
D243		MG75E0635	ヌイメカケンウテクミタテ	Reverse sewing crank assy.	1
D244		M91501007	マルヒラネジホウサキ	Screw 15/64(28)x14.5	1
D245		MG75A1572	ツルマキハネ	Spring	1
D246		MF00A1708	カケカネ	Spring holder	1
D247		M91505002	ヒラネジ	Screw 15/64(28)x13.5	1
D248		MN15A0708	カケカネ	Spring holder	1
D249		MG75A2572	ツルマキハネ	Spring	1
D910		MG75E0640	オクリチヨウセツシクミタテ	Screw bar assy.	1

⑤ 上部水平送り機構
UPPER FEED ROCK SHAFT MECHANISM

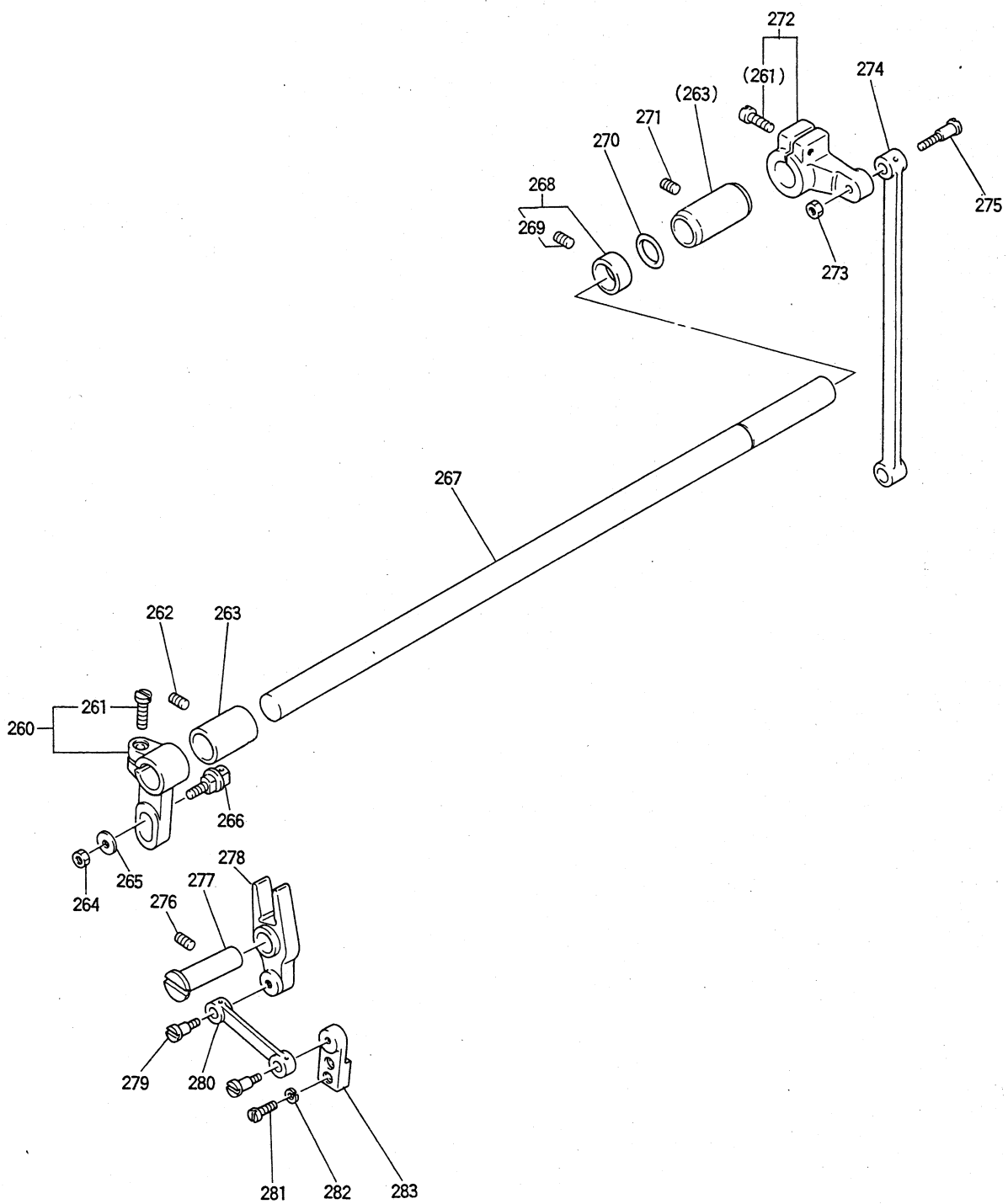

E 上部水平送り機構

UPPER FEED ROCK SHAFT MECHANISM

Fig. 変更 部品コード				使用数	
No.	Mod	Parts.No.	部 品 名	Description	Amt. Reg.
					811
E260		MG75E0464	シヨウフスハイウテヒタリクミ	Upper feed rock shaft crank(left)	1
E261		M91507002	ヒラネジ	Screw 15/64(28)x18	2
E262		M91108001	トメネジ	Set screw 11/64(40)x5.5	1
E263		MG75A0286	オクリシクメタル	Bushing for upper feed rock shaft	2
E264		M91604045	ナット	Nut 1/4(24)	1
E265		M90601050	ミカキサカネ 6	Washer 6	1
E266		MG50E0410	コロサエシククミタテ	Feed connecting slick block complete	1
E267		MG75A1491	シヨウフスハイオクリシク	Upper feed rock shaft	1
E268		MF80A0352	カラクミタテ	Thrust collar with screw	1
E269		M91602001	トメネジ	Set screw 1/4(40)x4	2
E270		M91200085	Oリング	O-ring S12	1
E271		M91108001	トメネジ	Set screw 11/64(40)x5.5	1
E272		MG75E0465	シヨウフスハイウテミキクミタテ	Upper feed rock shaft crank (right)	1
E273		M91802045	ナット	Nut 9/32(28)	1
E274		MG75A4956	レンセツカン	Feed driving connecting rod	1
E275		M91803015	ヒラネジタンツキ	Hinged screw 9/32(28)x7	1
E276		M91506001	トメネジ	Set screw 15/64(28)x6.5	1
E277		MG75A0530	タンツキシク	Hinged pin	1
E278		MG75A0950	ハンカンレバ	Feed connecting lever	1
E279		M91681015	ヒラネジタンツキ	Hinged screw 1/4(40)x12	2
E280		MG75A5956	レンセツカン	Walking foot connecting rod	1
E281		M90903002	ヒラネジ	Screw 9/64(40)x6.5	2
E282		M90304053	ハネサカネ 3.5	Spring washer 3.5	2
E283		MG75A1602	トリツカガネ	Feed arm	1

⑥ 上部上下送り機構

UPPER FEED LIFTING ROCK SHAFT MECHANISM

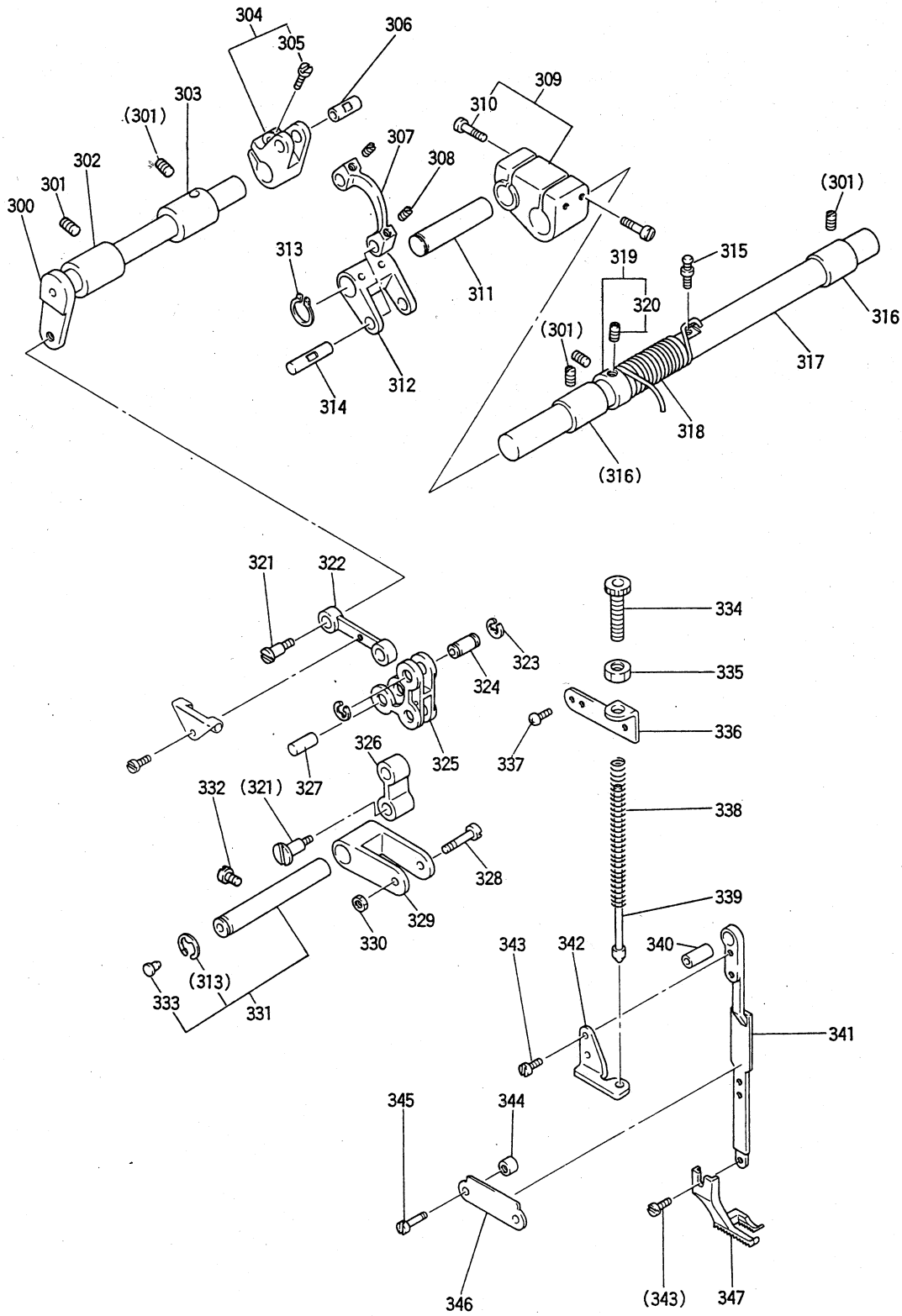

F 上部上下送り機構

UPPER FEED LIFTING ROCK SHAFT MECHANISM

Fig. 変更 部品コード				使用数	
No.	Mod	Parts.No.	部品名	Description	Amt. Reg.
					BIT
F300		MG75A0460	シヨウフシヨウケシク	Upper feed lifting rock shaft	1
F301		M91108001	トメネジ	Set screw 11/64(40)X5.5	4
F302		MG75A1286	シヨウフシヨウケメタル	Bushing for upper feed lifting rock shaft	1
F303		MG75A0287	シヨウフシヨウケメタル	Bushing for upper feed lifting rock shaft	1
F304		MG75E0463	シヨウフシヨウケウデミキクミタテ	Feed lifting rock shaft crank(right)assy	1
F305		M91505002	ヒラネジ	Screw 15/64(28)X13.5	1
F306		MG75A4454	シク	Upper feed lifting rock crank shaft	1
F307		MG75A6956	レンセツカン	Link	1
F308		M91106001	トメネジ	Set screw 11/64(40)X3.8	2
F309		MG75E0564	オクリチヨウセツタイクミタテ	Upper feed regulator bracket	1
F310		M91113002	ヒラネジ	Screw 11/64(40)X15	4
F311		MG75A5454	シク	Shaft	1
F312		MG75A2910	リンク	Link	1
F313		M90516065	Cカトメワシクヨウ 10	C-type stop ring 10	2
F314		MG75A6454	シク	Pin	1
F315		M91508030	トクシユネジ	Screw 15/64(28)X10	1
F316		MG75A0285	オクリシクメタル	Upper feed shaft bushing	2
F317		MG75A0559	オクリチヨウセツシク	Upper feed regulator shaft	1
F318		MG75A0729	ヒネリハネ	Coil spring	1
F319		MF80A0352	カラクミタテ	Thrust collar assy	1
F320		M91602001	トメネジ	Set screw 1/4(40)X4	2
F321		M91681015	ヒラネジタンツキ	Hinged screw 1/4(40)X12	2
F322		MG75A7956	レンセツカン	Feed lifting rock shaft link	1
F323		M90511065	Eカトメワシク 6	E-type stop ring 6	2
F324		MG75A7454	シク	Pin	1
F325		MG75A0763	ベルクランク	Bell crank	1
F326		MG75A8956	レンセツカン	Link	1
F327		MG75A8454	シク	Pin	1
F328		M91522015	ヒラネジタンツキ	Stud screw 15/64(28)X5	1
F329		MG75A0765	ベルクランクササエ	Bell crank supporter	1
F330		M91501045	ナット	Nut 15/64(28)	1
F331		MG75E0454	シククミタテ	Bell crank support shaft	1
F332		M91502002	ヒラネジ	Screw 15/64(28)X12	1
F333		M90573080	セン	Rubber plug φ5.7	1
F334		M91801035	ツマミネジ	Feed regulating screw 9/32(28)X31	1
F335		M91802045	ナット	Nut 9/32(28)	1
F336		MG75A0564	オサエチヨウセツタイ	Presser regulating bracket	1
F337		M91106004	フロマイネジ	Screw 11/64(40)X8	2
F338		MG75A4572	ツルマキハネ	Spring	1
F339		MG75A0154	アンナイカネクミタテ	Spring guide bar complete	1
F340		MG75A0750	フツシユ	Walking foot guide link bushing	1
F341		MG75A0295	オクリアシサエ	Walking foot guide link	1
F342		MG75A0708	ハネカケカネ	Spring holder	1
F343		M90922002	ヒラネジ	Screw 9/64(40)X8	3
F344		M93009050	サカネ	Washer	2
F345		M91112002	ヒラネジ	Screw 11/64(40)X12	2
F346		MG30A0296	ソトサエアンナイ	Walking foot guide bracket	1
F347		MG10B0294	ソトサエ	Walking foot	1

7 押え機構

PRESSER FOOT MECHANISM

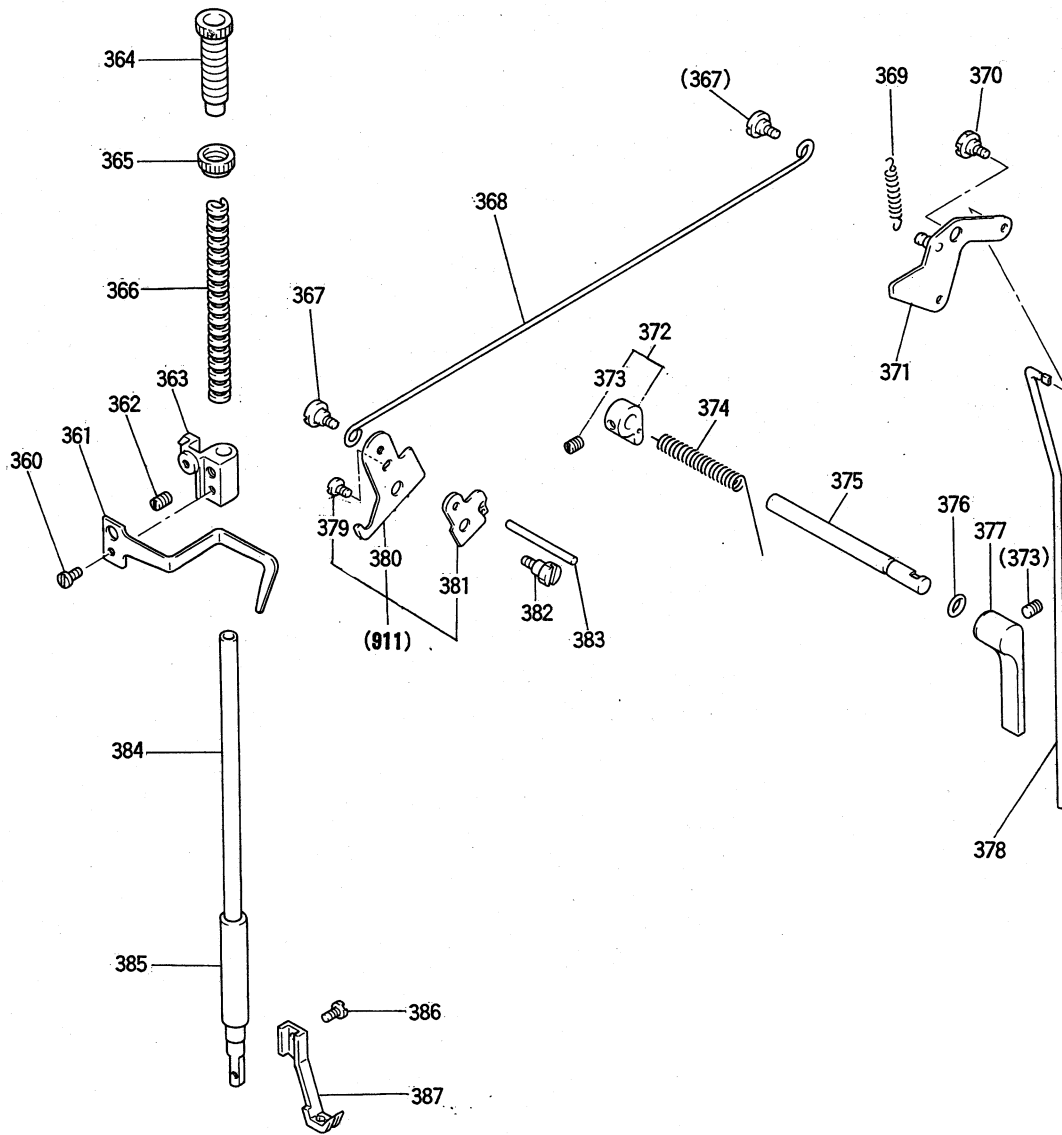

G 押え機構

PRESSER FOOT MECHANISM

Fig. 変更 No.	部品コード Mod	部品名 Parts.No.	Description	使用数 Amt. Reg.
G360	M91109002	ヒラネジ	Screw 11/64(40)x7	1
G361	MG75A0216	ウワイトアンナイ	Thread guide	1
G362	M91506001	トメネジ	Set screw 15/64(28)x7	1
G363	MG75A0265	オサエホウタキ	Presser bar guide bracket	1
G364	M93221035	ツマミネジ	Thumb screw 1/2(28)x43	1
G365	M93202047	トクシユナツト	Nut 1/2(28)	1
G366	MG75A0259	オサエハネ	Presser bar spring	1
G367	M91219015	ヒラネジ タンツキ	Stud screw 3/16(28)X3.5	2
G368	MG75A0738	ヒキホウ	Knee lifter rod	1
G369	MG75A3572	ツルマキハネ	Coil spring	1
G370	M91503031	ホルト	Bolt 15/64(28)X6.5	1
G371	MG75E0252	オサエケレハ-ミキクミタテ	Knee lifter lever assy.	1
G372	MG75E0253	オサエケカムクミタテ	Presser bar lifting cam assy.	1
G373	M91503001	トメネジ	Set screw 15/64(28)x4.5	2
G374	MG75A1729	ヒネリハネ	Coil spring	1
G375	MG75A9454	オサエケシク	Presser foot lifting shaft	1
G376	M90500085	リング	O-ring 1AP5	1
G377	MG75A0252	オサエケレハ	Presser bar lifter	1
G378	MG75A0511	ソウサホウ	Knee lifter connecting rod	1
G379	M91131002	ヒラネジ	Screw 11/64(40)X6.5	1
G380	—	オサエケレハ-ヒタリ	Knee lifter lever(left)	1
G381	—	イトユルメカム	Tension releasing cam	1
G382	M91504031	タンツキホルト	Stud Bolt 15/64(28)X7	1
G383	M90423060	イトユルメピン	Thread releasing pin	1
G384	MG75A0262	オサエホウ	Presser bar	1
G385	MF00A0267	オサエホウメタル	Bushing for presser bar busing	1
G386	M90922002	ヒラネジ	Screw 9/64(40)x8	1
G387	MG52E0256	ウチオサエクミタテ	Presser foot assy.	1
G387	MG41B0256	オサエアシ	Presser foot	(1)
G911	MG75E1252	オサエケレハ-ヒタリクミタテ	Knee lifter lever(left)assy.	1

⑧ 糸切り機構
KNIFE ACTUATING MECHANISM

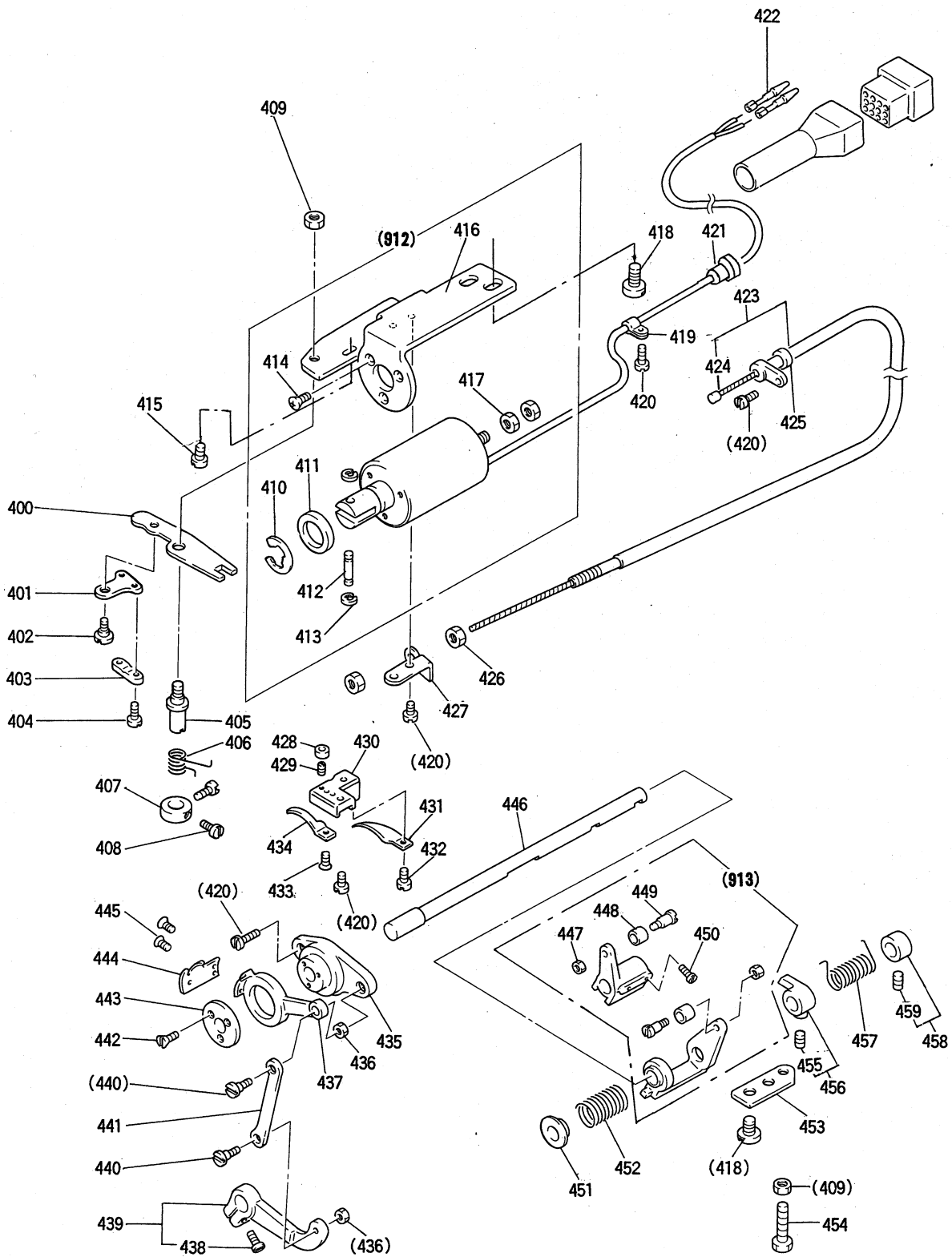

H 系切り機構

KNIFE ACTUATING MECHANISM

Fig.	変更	部品コード			使用数
No.	Mod	Parts.No.	部品名	Description	Amt.Reg.
					BIT
H400		MF00A1391	クトウウタ	Thread trimmer driving lever	1
H401		MF90A0361	カカネ	Flexible wire holder	1
H402		M91127015	ヒラネジタツキ	Stud screw 11/64(40)x5	1
H403		MF36A0750	フツシユ	Flexible wire presser	1
H404		M90802002	ヒラネジ	Screw 1/8(44)x7	2
H405		M97082030	トクシユネジ	Stud screw 15/64(28)x7.5	1
H406		MF00A1729	ヒネリハネ	Trimming lever spring	1
H407		MF00A1352	カラ	Spring support collar	1
H408		M90903002	ヒラネジ	Screw 9/64(40)x6.5	2
H409		M91502045	ナット	Nut 15/64(28)	2
H410		M90703065	エタメリ 12	E-type stop ring 12	1
H411		MF01A0397	クッション	Cushion	1
H412		M90516063	ピン	Pin	1
H413		M90504065	エタメリ 4	E-type stop ring 4	2
H414		M94008037	Pサネジ M4x6	Screw M4x6	3
H415		M91118002	ヒラネジ	Screw 11/64(40)x10	1
H416		MF00A1509	ソレノイドトリツケイタ	Solenoid bracket	1
H417		M92074075	ナット M5	Nut M5	2
H418		M91510002	ヒラネジ	Screw 15/64(28)x12	4
H419		M94003099	ナイロンクリップ AB-3N	Cord holder AB-3N	1
H420		M91106004	フライネジ	Screw 11/64(40)x8	7
H421		M91004080	フツシユ	Bushing	1
H422		M93003099	ピンターミナル(オス)	Terminal pin(Male)	2
H423		MG75E0746	フレキシブルワイヤクミタテ	Flexible wire assy.	1
H424		MG75A1746	フレキシブルワイヤ	Flexible wire	1
H425		M90400085	O リング 1AP4	O-ring 1AP4	1
H426		M91373045	ナット M5	Nut M5x4T	2
H427		MF00A0780	ホルダ	Holder	1
H428		M91110045	ナット	Nut 9/64(40)	1
H429		M90913001	トメネジ	Set screw 9/64(40)x8.5	1
H430		MF00A1603	トリツケイタ	Bracket for fixed blade	1
H431		MG52A0180	イトアンナイ	Thread guide	1
H432		M90921002	ヒラネジ	Screw 9/64(40)x8	1
H433		M90907010	サネジ	Screw 9/64(40)x5	1
H434		MG52A0838	コテイメス	Fixed blade	1
H435		MF00A1527	タサ	Knife holding bracket saddle	1
H436		M91107045	ナット	Nut 11/64(40)	2
H437		MF02A0836	メスタヒタリ	Knife base (left)	1
H438		M91117002	マルヒラネジ	Screw 11/64(40)x13	1
H439		MF00A1392	クトウウタ	Knife driving crank	1
H440		M91111015	ヒラネジタツキ	Stud screw 11/64(40)x6.2	2
H441		MF00A8910	リンク	Link	1
H442		M90803010	サネジ	Screw 1/8(44)x6	3
H443		M94006052	サカネ	Thrust collar ϕ 28	1
H444		MG52A0834	メスタヒタリ	Movable knife (left)	1
H445		M91151010	サネジ	Screw 11/64(40)x7	2
H446		MF00A5454	メソウトウシク	Knife driving shaft	1
H447		M91201045	ナット	Nut 3/16(28)	2
H448		MF00A0411	コロ	Roller	2
H449		MF00A0412	コロシク	Roller stud	2
H450		M91516002	ヒラネジ	Screw 15/64(28)x8.5	2
H451		MF00A0750	フツシユ	Bushing	1
H452		MF00A9572	ツルマキハネ	Coil spring	1
H453		MF00A1477	ストッパイタ	Lever stopper plate	1
H454		M91512022	ホルト	Bolt 15/64(28)x23	1
H455		M91606001	トメネジ	Set screw 1/4(40)x5	1
H456		MH00A2477	ストッパクミタテ	Stopper assy.	1
H457		MF00A0729	ヒネリハネ	Coil spring	1
H458		MF01E1352	カラクミタテ	Thrust collar assy.	1
H459		M91602001	トメネジ	Set screw 1/4(40)x4	1
H912		MG75E2519	イトクリソレノイドクミタテ	Thread trimming solenoid	1
H913		MF01E0351	カムツイシユウウテクミタテ	Cam follower crank assy.	1

⑨ タッチバック機構および検出器機構
TOUCH BACK MECHANISM & DETECTOR MECHANISM

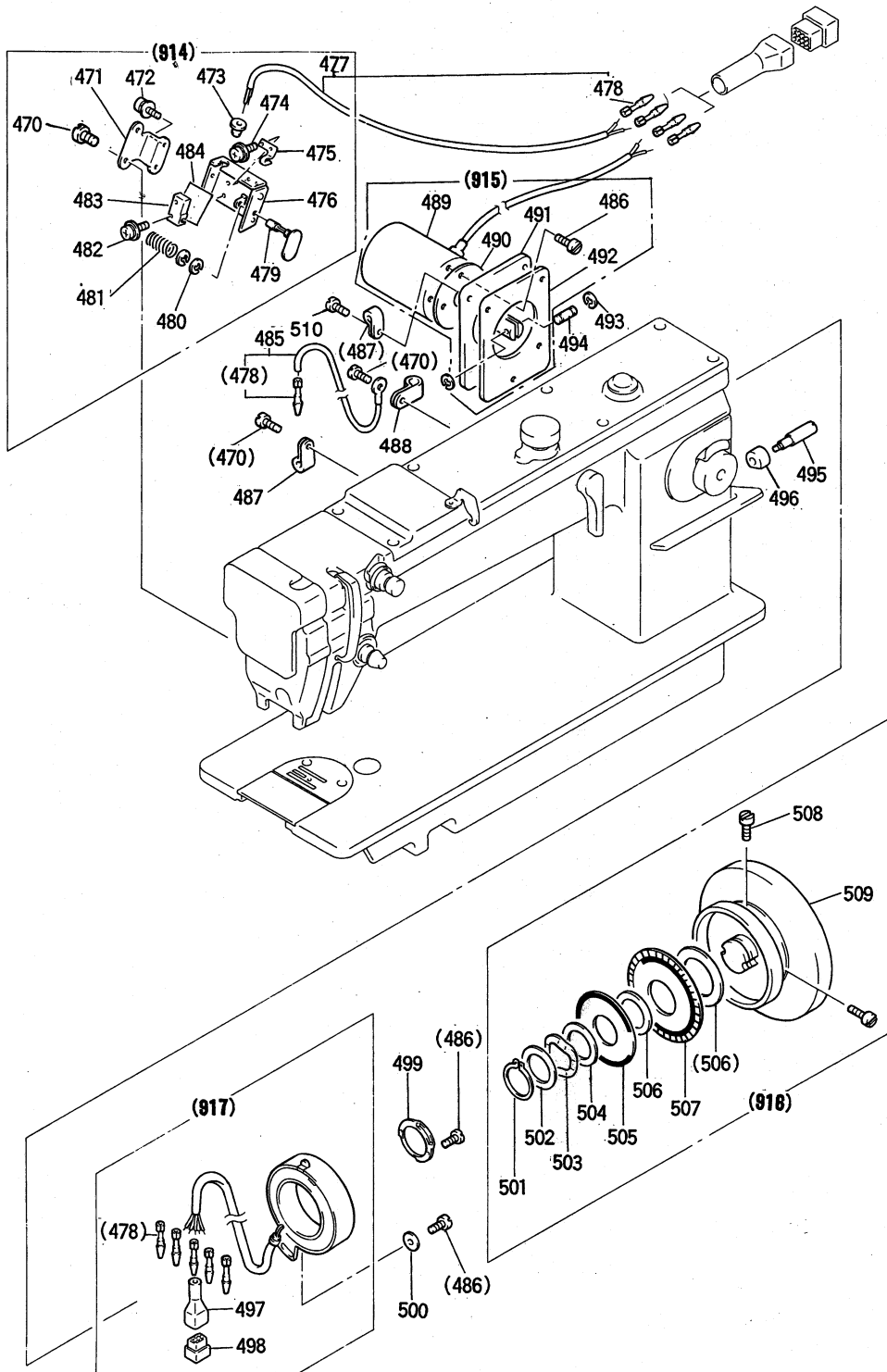

J タッチバック機構および検出器機構

TOUCH BACK MECHANISM & DETECTOR MECHANISM

Fig. No.	変更 Mod	部品コード Parts.No.	部品名	Description	使用数 Amt. Reg.
J470		M91109004	サカネツキフ ^o ラマイネジ	Screw 11/64(40)X8	8
J471		MG75A0601	トリツケイタ	Bracket	1
J472		M90309037	SW-PWツキ Pナネジ	Screw M3X5	2
J473		M91003080	コム ^o ツシ	Rubber plug	1
J474		M90201037	Pナネジ	Screw 2X4	2
J474		M90315050	コサカネM2	Washer M2	2
J474		M90306053	ハネサカネM2	Washer M2	2
J475		MF00A0192	イタハネ	Plate spring	1
J476		MG75A1601	スイッチトリツケイタ	Bracket for touch switch	1
J477		M97070095	コードクミタテ	Cord assy.	1
J478		M93303099	ピン 1380TL	Terminal pin	5
J479		MF00A0270	オシホタン	Push button	1
J480		M90512065	Eカ ^o タメワ 3	E-type stop ring 3	2
J481		MF00A7572	ツルマキハネ	Coil spring	1
J482		M90251037	Pハ ^o イントネジ	Screw M2X8	2
J483		M90208099	マイクロスイッチ	Micro switch	1
J484		MF01A0502	セツエンイタ	Insulator seat	1
J485		M97003095	ア ^o スセクミタテ	Ground wire assy.	1
J486		M91106004	フ ^o ラマイネジ	Screw 11/64(40)x8	7
J487		M94003099	ナイロンクリップ AB-3N	Cord holder	2
J488		MB60A1620	ナイロンクリップ AB-8N	Cord holder	1
J489		M91021095	ソレノイド	Solenoid	1
J490		MF01A0691	カスケツト	Gasket	1
J491		MG75A1880	ヨコフタ ^o 2	Arm side cover-2	1
J492		MG75A2691	カスケツト	Gasket	1
J493		M90504065	Eカ ^o タメワ 4	E-type stop ring 4	2
J494		M90516063	ピン	Pin	1
J495		MG75A0426	サエ	Stud screw	1
J496		MN36A0417	コム	Rubber cushion	1
J497		MF06E0366	コネクタ ^o キャップクミタテ	Connector cap assy.	1
J498		M91018099	コネクタ-1360P	Nylon connector 12-pole	1
J499		MF01A0257	オサエイタ	Detector bracket supporter	1
J500		M93002050	サカネ	Washer 12	1
J501		M90330065	カ ^o タメワ	Retaining ring-C type 30	1
J502		M93001050	サカネ	Washer 30	1
J503		MF01A0259	ハンテンイタオサエス ^o リンク	Supporter spring	1
J504		MF01A1476	スペ ^o サ B	Spacer B	1
J505		MF01A1694	ハンシャ ^o ン B21	Speed command disc B21(up)	1
J506		MF01A0476	スペ ^o サ A	Spacer A	2
J507		MF01A2694	ハンシャ ^o ン B12	Speed command disc B12(down)	1
J508		M91502002	ヒラネジ	Set screw 15/64(28)X12	2
J509		MG75A0682	プ ^o リ	Pulley	1
J510		M91111004	フ ^o ラマイネジ	Screw 11/64(40)X10	1
J914		MG75E0534	タッチスイッチクミタテ	Touch switch assy.	1
J915		MG75E3519	ヨコフタ ^o ソレノイドクミタテ	Arm side cover solenoid assy.	1
J916		MG75E0682	プ ^o リクミタテ	Pulley assy.	1
J917		MB60A2406	ケンシツキクミタテ(センサー)	Detector bracket assy.(sensor)	1

10 給油機構

OIL LUBRICATION MACHANISM

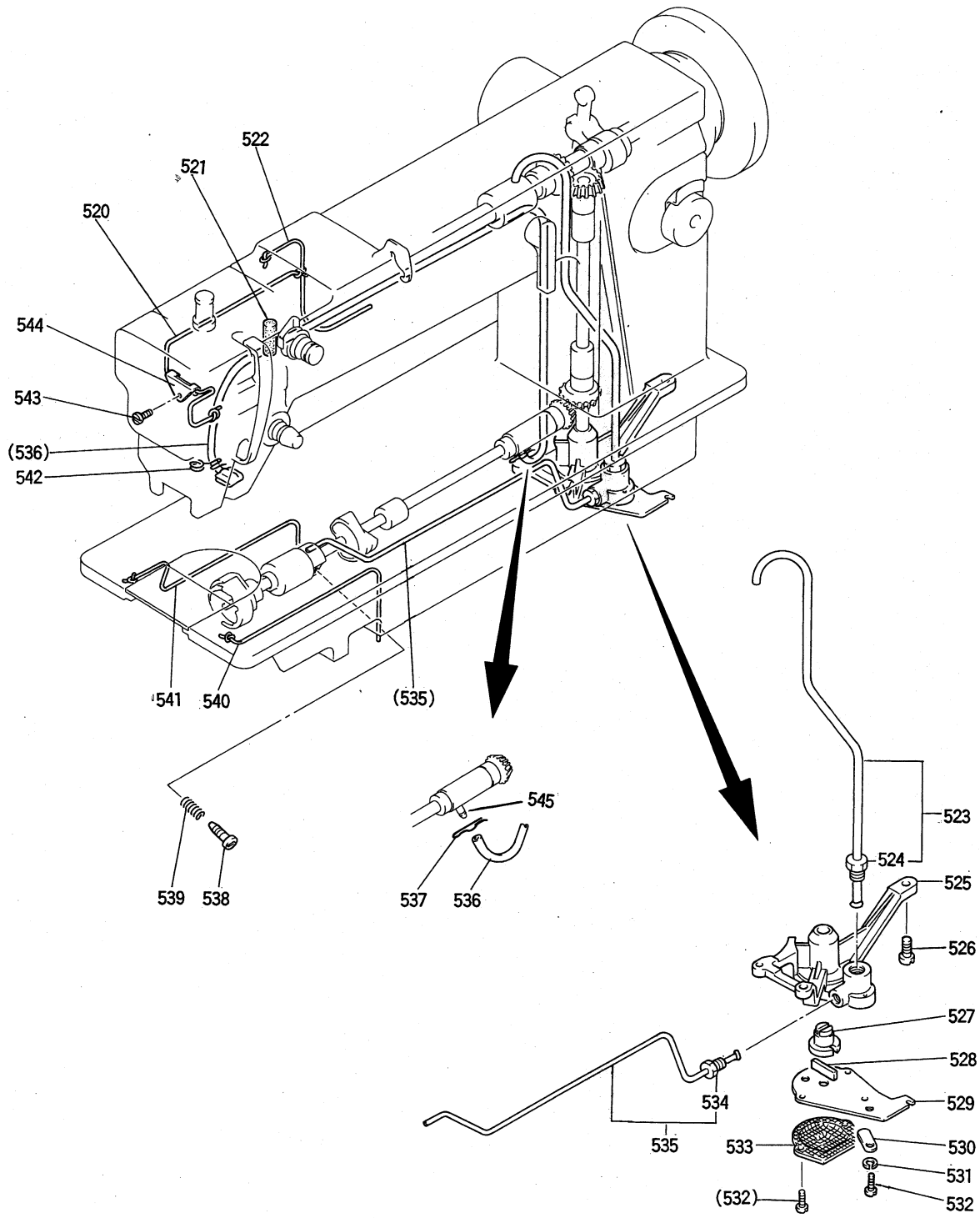

K 給油機構

OIL LUBRICATION MECHANISM

Fig. No.	変更 Mod	部品コード Parts.No.	部品名	Description	使用数 Amt. Reg. BIT
K520		MG75A0148	ヒモ	Oil wick	1
K521		MF01A2740	フェルト	Oil felt $\phi 8 \times 30$	1
K522		MG75A1148	ヒモ	Oil wick $\phi 1.5 \times 100$	1
K523		MG75E0688	ハ ^イ °ウエクミタテ	Upper shaft oil tube assy.	1
K524		MF40A1750	フツシユ	Oil tube lock bushing 1/2(28)	1
K525		MG75E0783	ポンプケース	Oil pump	1
K526		M91103004	フ ^ラ マイネジ	Screw 11/64(40)x13	3
K527		MG75A0977	ローター	Roter	1
K528		MG75A0496	スライダ	Slider	1
K529		MG75A2601	トリツキイタ	Oil pump fitting plate	1
K530		MF10A1742	フタ	Oil adjusting plate	1
K531		M90304053	ハ ^ネ サ ^カ ネ 3.5	Spring washer M3.5	1
K532		M90801004	フ ^ラ マイネジ	Screw 1/8(44)x13	3
K533		MF10E0337	アミクミタテ	Oil pump filter	1
K534		M92201047	フツシユ	Bushing 11/32(28)	1
K535		MG75E2688	キュウハ ^イ °シタクミタテ	Lower shaft Oil tube assy.	1
K536		MG75E0731	カンユハ ^イ °クミタテ	Oil return pipe assy.	1
K537		MF01A0378	タ ^ル ムクリツツ [°] 6	Holder for oil braid 6	1
K538		M97084030	トクシユネジ	Oil adjusting screw	1
K539		MF80A1572	ツルマキハ ^ネ	Spring	1
K540		MF00A0148	ヒモ	Oil wick $\phi 2.5 \times 240$	1
K541		MG75A0148	ヒモ	Oil wick $\phi 2.5 \times 315$	1
K542		MF00A2780	ホルダ	Holder	1
K543		M90906002	ヒラネジ	Screw 9/64(40)x4.5	1
K544		MG75A0780	ホルダ	Holder	1
K545		MF80A0688	ハ ^イ °	Oil pipe	1

11 付属品
ACCESSORIES

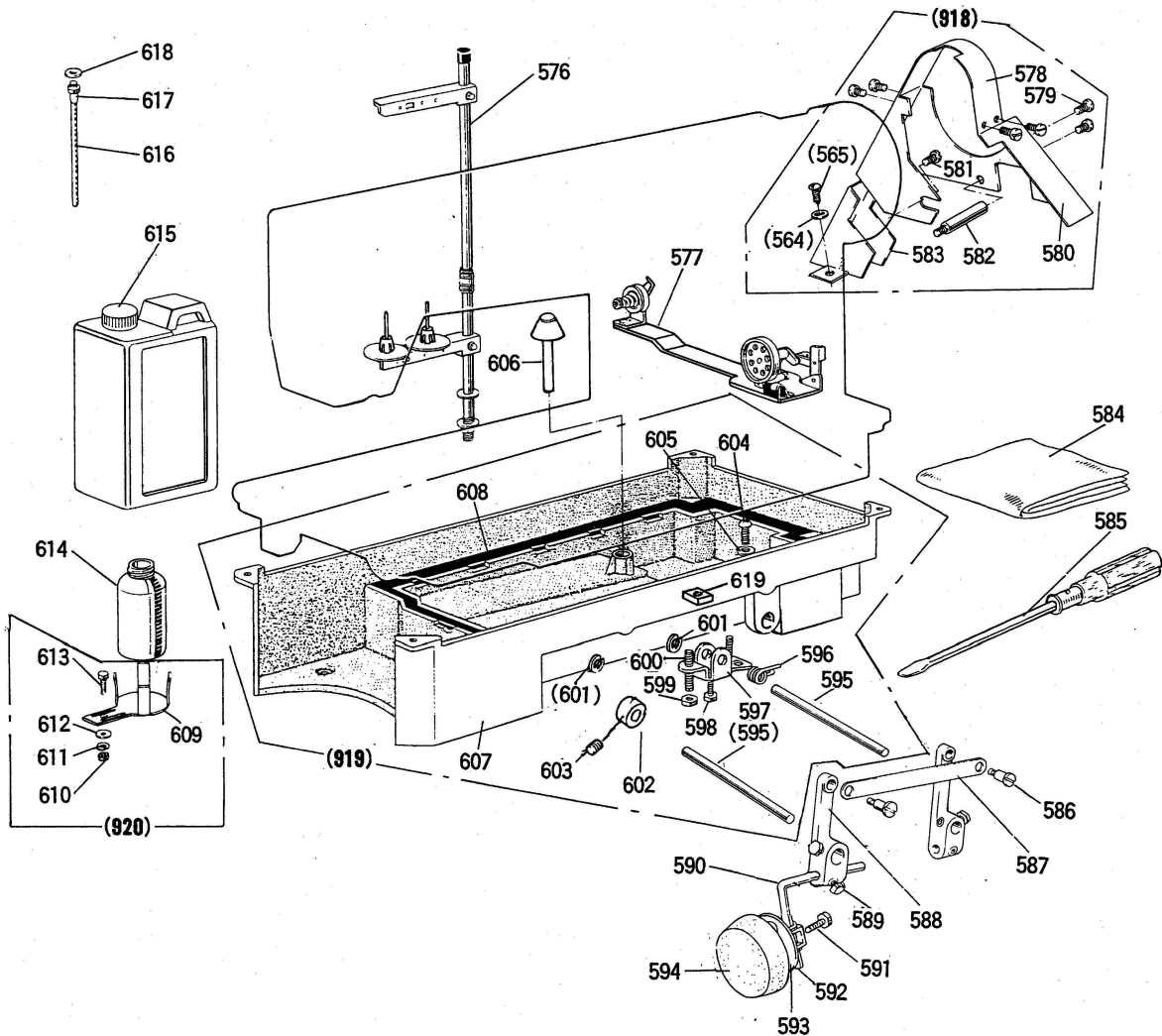
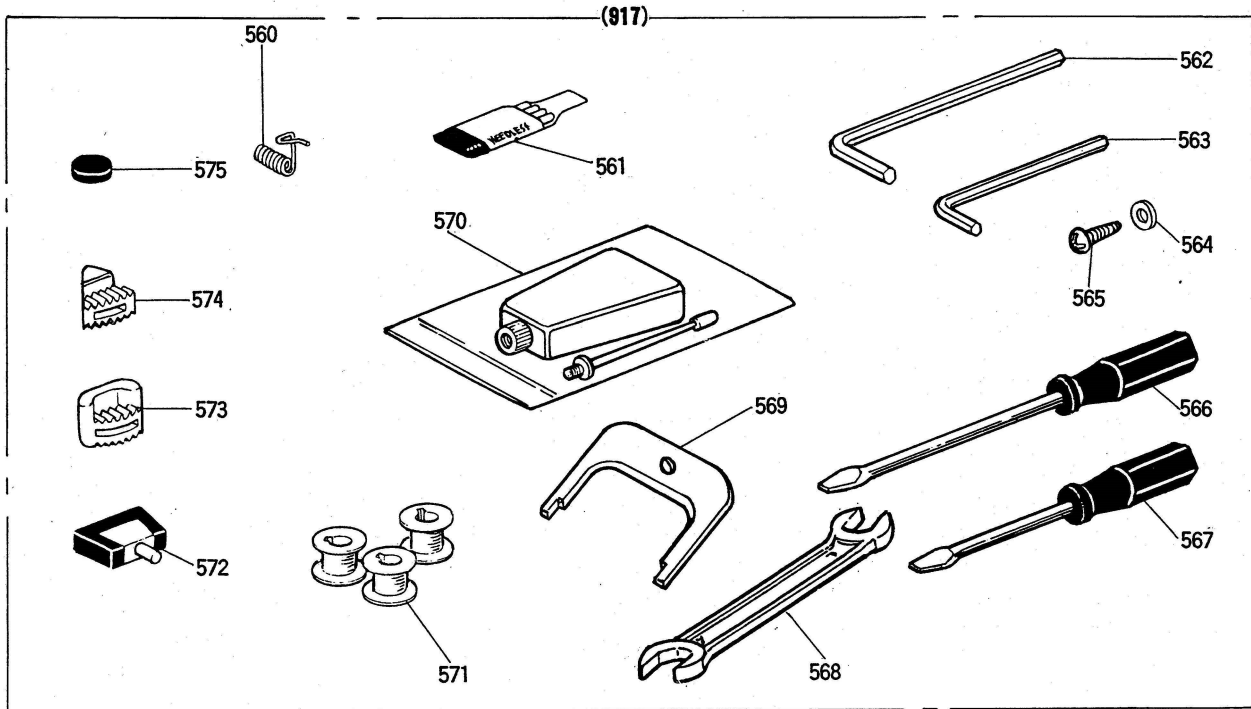

L 付属品関係
ACCESSORIES

Fig. No.	変更 Mod	部品コード Parts.No.	部品名	Description	使用数 Amt. Reg.
L560		MF83A1187	イトリハネ	Thread take-up spring	1
L561		MG37A0128	ハリ	Needle DPX17 #22	4
L562		MS02A2976	ソツカクホウスハナ 3	Socket wrench 3	1
L563		MF90A2976	ソツカクホウスハナ 2	Socket wrench 2	1
L564		M90550050	ミカキサカネ 5	Washer M5	4
L565		M90401041	マルモクネシ 4.5X20	Screw 4.5X20	4
L566		MB02A0608	ネジマワシ(チユウ)	Screw driver(middle)	1
L567		MB02A1608	ネジマワシ(ショウ)	Screw driver(small)	1
L568		MM10A1479	スハナ マルカク	Spanner	1
L569		MF01A0565	カクテチヨウセイク	Speed command disc adjusting plate	1
L570		MF60A0137	アブラサシ	Oil with oiler	1
L571		MF25B0123	ホビン	Bobbin	3
L572		MF01E0418	チヨウハンセット	Table hinge with rubber cushion	2
L573		MG75A0419	ホウシンゴム	Vibration preventing rubber	2
L574		MN70A1419	ホウシンゴム	Vibration preventing rubber	2
L575		M90701099	OP-S シシヤク	Magnet block for reservoir	1
L576		MF40E0193	イトタテイクミタテ2	Thread stand assy	1
L577		MF03E1193	イトマキシカケ	Bobbin winder complete	1
L578		MG75A0776	ベルトカバー-2	Belt cover2	1
L579		M91114004	フライネジ	Screw 15/64(40)X5.5	6
L580		MG75A1776	ベルトカバー-1	Belt cover1	1
L581		M91508004	フライネジ	Screw 15/64(28)X8	1
L582		MG75A0426	ササエ	Stud screw	1
L583		MG75A2776	ベルトカバー-3	Belt cover3	1
L584		MF60A0734	ビニールカバー	Vinyl cover	1
L585		MF00A0608	ネジマワシ(タイ)	Screw driver(large)	1
L586		M91601016	マルヒラネジタツキ	Screw 1/4(24)X10.7	2
L587		MG75A3910	リンク	Link	1
L588		MG75A1392	クドウウテ	Knee lifter driving crank	2
L589		M92001031	トクシホルト	Bolt 5/16(18)X13	3
L590		MG75A1511	ソウサホウ	Knee lifter shaft	1
L591		M91510022	ホルト	Bolt 15/64(28)X8	1
L592		MF30A0477	ストッパ	Knee lifter plate stopper	1
L593		MF40A0737	ヒザアテイタ	Knee lifter plate	1
L594		MF40A1737	ヒザアテ	Knee lifter cover	1
L595		MG75A1723	ヒザアケシク	Knee lifter shaft	2
L596		MF20A1729	ヒネリハネ	Knee lifter spring	1
L597		MG75A0724	ヒザアケレハ	Knee lifter	1
L598		M91511022	ホルト	Bolt 15/64(28)X14	1
L599		M91501045	ナット	Nut 15/64(28)	2
L600		M91520001	トメネジ	Set screw 15/64(28)X28	2
L601		M90515065	エカトメワ 9	E-type stop ling 9	2
L602		MM11A2352	カラ	Collar	1
L603		M91503001	トメネジ	Set screw 15/64(28)X3.5	2
L604		M92002002	ヒラネジ	Oil drain screw 5/16 (28)X10	1
L605		M97001052	トクシサカネ	Washer	1
L606		MF70A1578	ヒザアケピン	Knee lifter lifting pin	1
L607		MG75A1139	アブラソウ	Oil reservoir	1
L608		MG75A3691	カスケツト	Gasket for oil reservoir	2
L609		MF20A0131	アブラウケタイ	Oil bottle holder	1
L610		M91573045	ナット M6	Nut M6	1
L611		M90601053	ハネサカネ6	Spring washer 6	1
L612		M90702050	サカネ	Washer 8	1
L613		M91551022	ホルト	Bolt 6X12	1
L614		MF20A0130	アブラビン	Oil bottle	1
L615		MF10E0149	アブラカン	Oil can	1
L616		MF36A0731	パイプ	Drainage tube	1
L617		M92001047	トクシネジ	Screw	1
L618		MF10A4691	カスケツト	Gasket	1
L619		MG75A3601	トリツケイタ	Adapter	1
L917		MG75E0749	フツクヒンバコセット	Accessories box set	1
L918		MG75E1776	ベルトカバー-セット	Belt cover assy.	1
L919		MG75E0139	アブラソウセット	Oil reservoir complete	1
L920		MF03E0131	アブラウケタイセット	Oil bottle holder assy.	1

M 索引
INDEX

部品コード*	ページ*	Fig	部品コード*	ページ*	Fig	部品コード*	ページ*	Fig
Parts.No.	Page	No.	Parts.No.	Page	No.	Parts.No.	Page	No.
M90106053	P03	A25	M90922002	P15	G386	M91502002	P19	J508
M90201037	P19	J474	M91000085	P09	D229	M91502045	P17	H409
M90208099	P19	J483	M91003080	P19	J473	M91502050	P07	C183
M90228060	P03	A43	M91004080	P17	H421	M91503001	P07	C184
M90251037	P19	J482	M91018099	P19	J498	M91503001	P15	G373
M90304053	P11	E282	M91021095	P19	J489	M91503001	P23	L603
M90304053	P21	K531	M91053020	P03	A11	M91503031	P15	G370
M90306053	P19	J474	M91070003	P03	A58	M91504031	P15	G382
M90309037	P19	J472	M91101046	P03	A27	M91505002	P09	D247
M90315050	P19	J474	M91102011	P03	A56	M91505002	P13	F305
M90315065	P07	C153	M91103004	P21	K526	M91506001	P05	B093
M90320065	P05	B096	M91106001	P07	C171	M91506001	P09	D213
M90330065	P19	J501	M91106001	P13	F308	M91506001	P11	E276
M90400085	P17	H425	M91106003	P03	A57	M91506001	P15	G362
M90401041	P23	L565	M91106004	P03	A15	M91507002	P07	C147
M90402085	P05	B115	M91106004	P05	B080	M91507002	P11	E261
M90423060	P15	G383	M91106004	P07	C133	M91508001	P03	A34
M90431060	P03	A10	M91106004	P09	D209	M91508004	P23	L581
M90500085	P15	G376	M91106004	P13	F337	M91508030	P13	F315
M90504065	P09	D215	M91106004	P17	H420	M91510002	P17	H418
M90504065	P17	H413	M91106004	P19	J486	M91510022	P23	L591
M90504065	P19	J493	M91107002	P03	A35	M91511022	P23	L598
M90511065	P13	F323	M91107045	P17	H436	M91512022	P17	H454
M90512065	P19	J480	M91108001	P03	A23	M91513001	P05	B077
M90515065	P23	L601	M91108001	P09	D203	M91513001	P05	B106
M90516063	P17	H412	M91108001	P11	E262	M91513001	P07	C173
M90516063	P19	J494	M91108001	P11	E271	M91513001	P09	D204
M90516065	P13	F313	M91108001	P13	F301	M91515002	P07	C177
M90550050	P23	L564	M91109002	P03	A07	M91515002	P09	D238
M90573080	P03	A02	M91109002	P15	G360	M91516002	P07	C146
M90573080	P13	F333	M91109004	P03	A03	M91516002	P09	D219
M90600085	P09	D242	M91109004	P19	J470	M91516002	P17	H450
M90601050	P11	E265	M91110045	P17	H428	M91520001	P23	L600
M90601053	P23	L611	M91111004	P19	J510	M91521002	P07	C141
M90604002	P03	A52	M91111015	P17	H440	M91522015	P13	F328
M90619050	P07	C134	M91112002	P07	C139	M91551022	P23	L613
M90700085	P05	B086	M91112002	P13	F345	M91571045	P23	L610
M90700085	P09	D227	M91113002	P13	F310	M91601016	P23	L586
M90701099	P23	L575	M91114004	P23	L579	M91602001	P05	B095
M90702050	P23	L612	M91117002	P17	H438	M91602001	P07	C151
M90703065	P17	H410	M91118002	P07	C159	M91602001	P09	D201
M90740080	P05	B111	M91118002	P09	D224	M91602001	P11	E269
M90800086	P07	C164	M91118002	P17	H415	M91602001	P13	F320
M90801004	P21	K532	M91127015	P17	H402	M91602001	P17	H459
M90802002	P17	H404	M91131002	P15	G379	M91602020	P07	C166
M90803010	P17	H442	M91151010	P17	H445	M91604045	P11	E264
M90806002	P07	C135	M91182080	P03	A37	M91605045	P03	A49
M90815002	P05	B075	M91200085	P11	E270	M91606001	P05	B084
M90883080	P03	A01	M91201045	P17	H447	M91606001	P17	H455
M90883080	P05	B070	M91204003	P07	C131	M91610001	P05	B102
M90901002	P03	A50	M91204003	P07	C179	M91681015	P11	E279
M90903002	P11	E281	M91207003	P09	D237	M91681015	P13	F321
M90903002	P17	H408	M91215002	P09	D236	M91801002	P05	B085
M90904060	P07	C180	M91219015	P15	G367	M91801035	P13	F334
M90904063	P09	D211	M91259030	P07	C162	M91802006	P05	B087
M90906002	P03	A38	M91373045	P17	H426	M91802045	P11	E273
M90906002	P21	K543	M91472086	P05	B101	M91802045	P13	F335
M90907010	P17	H433	M91501007	P09	D244	M91803015	P11	E275
M90909003	P03	A32	M91501045	P13	F330	M91910080	P03	A06
M90913001	P17	H429	M91501045	P23	L599	M92001031	P23	L589
M90921002	P17	H432	M91501085	P03	A40	M92001047	P23	L617
M90922002	P13	F343	M91502002	P13	F332	M92002002	P23	L604

M 索引
INDEX

部品コード	ページ	Fig	部品コード	ページ	Fig	部品コード	ページ	Fig
Parts.No.	Page	No.	Parts.No.	Page	No.	Parts.No.	Page	No.
M92004080	P09	D210	MF00A1708	P09	D246	MF25B0123	P23	L571
M92074075	P17	H417	MF00A1729	P17	H406	MF26B0101	P03	A55
M92200080	P03	A18	MF00A2708	P09	D221	MF30A0477	P23	L592
M92201047	P21	K534	MF00A2780	P21	K542	MF36A0245	P03	A28
M92601080	P03	A20	MF00A5454	P17	H446	MF36A0731	P23	L616
M92701080	P03	A24	MF00A7572	P19	J481	MF36A0750	P17	H403
M92900080	P03	A19	MF00A8910	P17	H441	MF40A0331	P05	B103
M93001050	P19	J502	MF00A9572	P17	H452	MF40A0332	P05	B110
M93002050	P19	J500	MF00E0281	P07	C137	MF40A0333	P05	B104
M93003099	P17	H422	MF00E0550	P03	A903	MF40A0334	P05	B109
M93009050	P13	F344	MF01A0257	P19	J499	MF40A0737	P23	L593
M93202047	P15	G365	MF01A0259	P19	J503	MF40A1737	P23	L594
M93221035	P15	G364	MF01A0378	P21	K537	MF40A1750	P21	K524
M93303099	P19	J478	MF01A0397	P17	H411	MF40E0193	P23	L576
M93600085	P09	D222	MF01A0476	P19	J506	MF60A0137	P23	L570
M94003099	P17	H419	MF01A0502	P19	J484	MF60A0663	P05	B071
M94003099	P19	J487	MF01A0565	P23	L569	MF60A0734	P23	L584
M94006052	P17	H443	MF01A0632	P09	D239	MF70A0286	P07	C182
M94008037	P17	H414	MF01A0691	P19	J490	MF70A0750	P09	D212
M95003053	P09	D240	MF01A0740	P05	B078	MF70A1578	P23	L606
M97001052	P23	L605	MF01A1476	P19	J504	MF74B0522	P05	B108
M97003095	P19	J485	MF01A1694	P19	J505	MF80A0352	P05	B094
M97006060	P05	B908	MF01A1740	P05	B113	MF80A0352	P07	C150
M97013060	P07	C148	MF01A2694	P19	J507	MF80A0352	P09	D200
M97070095	P19	J477	MF01A2740	P21	K521	MF80A0352	P11	E268
M97082030	P17	H405	MF01E0276	P07	C138	MF80A0352	P13	F319
M97084030	P21	K538	MF01E0331	P05	B905	MF80A0688	P21	K545
M97086030	P07	C154	MF01E0332	P05	B906	MF80A1572	P21	K539
M97088030	P07	C155	MF01E0351	P17	H913	MF83A0154	P07	C176
MB02A0608	P23	L566	MF01E0352	P07	C170	MF83A1187	P23	L560
MB02A1608	P23	L567	MF01E0418	P23	L572	MF85A0640	P09	D230
MB60A1620	P19	J488	MF01E1352	P17	H458	MF90A0278	P07	C130
MB60A2406	P19	J917	MF02A0187	P03	A42	MF90A0283	P07	C132
MF00A0148	P21	K540	MF02A0245	P09	D231	MF90A0361	P17	H401
MF00A0181	P03	A31	MF02A0553	P03	A44	MF90A2976	P23	L563
MF00A0192	P19	J475	MF02A0836	P17	H437	MG10B0294	P13	F347
MF00A0257	P09	D235	MF03A0245	P07	C157	MG30A0296	P13	F346
MF00A0267	P15	G385	MF03A0417	P05	B079	MG30A0601	P03	A36
MF00A0270	P19	J479	MF03A0557	P07	C156	MG37A0128	P05	B076
MF00A0277	P07	C178	MF03A0584	P03	A22	MG41B0256	P23	L561
MF00A0350	P07	C167	MF03E0131	P23	L920	MG42A0181	P15	G387
MF00A0411	P17	H448	MF03E1193	P23	L577	MG42A0181	P05	B074
MF00A0412	P17	H449	MF05A0234	P05	B092	MG43A0181	P03	A33
MF00A0451	P07	C165	MF05A0572	P09	D225	MG43A1181	P03	A51
MF00A0453	P07	C168	MF05A0740	P07	C163	MG44B0120	P07	C161
MF00A0553	P03	A30	MF06E0366	P19	J497	MG44E0125	P07	C909
MF00A0572	P07	C175	MF10A0151	P03	A26	MG44E0662	P05	B082
MF00A0608	P23	L585	MF10A0325	P05	B081	MG50E0410	P11	E266
MF00A0633	P09	D241	MF10A0471	P03	A53	MG52A0180	P17	H431
MF00A0729	P17	H457	MF10A0555	P03	A45	MG52A0245	P03	A47
MF00A0750	P17	H451	MF10A0709	P03	A41	MG52A0834	P17	H444
MF00A0753	P07	C174	MF10A1555	P03	A29	MG52A0838	P17	H434
MF00A0780	P17	H427	MF10A1742	P21	K530	MG52E0256	P15	G387
MF00A0852	P09	D226	MF10A4691	P23	L618	MG70A0600	P03	A16
MF00A0950	P09	D232	MF10E0149	P23	L615	MG70A0631	P03	A12
MF00A1352	P17	H407	MF10E0337	P21	K533	MG75A0104	P07	C136
MF00A1391	P17	H400	MF20A0130	P23	L614	MG75A0148	P21	K520
MF00A1392	P17	H439	MF20A0131	P23	L609	MG75A0148	P21	K541
MF00A1477	P17	H453	MF20A0135	P03	A14	MG75A0152	P09	D220
MF00A1509	P17	H416	MF20A0229	P07	C160	MG75A0154	P13	F339
MF00A1527	P17	H435	MF20A1729	P23	L596	MG75A0180	P03	A08
MF00A1603	P17	H430	MF25B0123	P07	C158	MG75A0216	P15	G361

M 索引
INDEX

部品コード	ページ	Fig	部品コード	ページ	Fig	部品コード	ページ	Fig
Parts.No.	Page	No.	Parts.No.	Page	No.	Parts.No.	Page	No.
MG75A0232	P05	B088	MG75A1491	P11	E267	MG75E0746	P17	H423
MG75A0233	P05	B100	MG75A1511	P23	L590	MG75E0749	P23	L917
MG75A0252	P15	G377	MG75A1572	P09	D245	MG75E0783	P21	K525
MG75A0259	P15	G366	MG75A1601	P19	J476	MG75E1230	P05	B907
MG75A0262	P15	G384	MG75A1602	P11	E283	MG75E1252	P15	G911
MG75A0265	P15	G363	MG75A1691	P03	A17	MG75E1492	P05	B099
MG75A0285	P07	C152	MG75A1723	P23	L595	MG75E1776	P23	L918
MG75A0285	P09	D202	MG75A1729	P15	G374	MG75E2519	P17	H912
MG75A0285	P13	F316	MG75A1746	P17	H424	MG75E2688	P21	K535
MG75A0286	P11	E263	MG75A1776	P23	L580	MG75E3519	P19	J915
MG75A0287	P13	F303	MG75A1880	P19	J491	MH00A2477	P17	H456
MG75A0291	P03	A21	MG75A1910	P09	D217	MM10A1479	P23	L568
MG75A0295	P13	F341	MG75A1956	P05	B097	MM11A0556	P03	A46
MG75A0417	P05	B114	MG75A2454	P09	D206	MM11A2352	P23	L602
MG75A0419	P23	L573	MG75A2572	P09	D249	MN15A0708	P09	D248
MG75A0426	P19	J495	MG75A2601	P21	K529	MN36A0417	P19	J496
MG75A0426	P23	L582	MG75A2691	P19	J492	MN40A0325	P07	C144
MG75A0450	P07	C169	MG75A2776	P23	L583	MN45A0154	P09	D208
MG75A0452	P07	C172	MG75A2910	P13	F312	MN70A1419	P23	L574
MG75A0454	P07	C140	MG75A2956	P05	B098	MQ50A0181	P03	A39
MG75A0460	P13	F300	MG75A3454	P09	D218	MS02A2976	P23	L562
MG75A0470	P03	A54	MG75A3572	P15	G369	MT60A0802	P03	A48
MG75A0491	P07	C149	MG75A3601	P23	L619			
MG75A0496	P21	K528	MG75A3691	P23	L608			
MG75A0511	P15	G378	MG75A3910	P23	L587			
MG75A0520	P05	B107	MG75A3956	P07	C142			
MG75A0521	P05	B105	MG75A4454	P13	F306			
MG75A0530	P11	E277	MG75A4572	P13	F338			
MG75A0559	P13	F317	MG75A4956	P11	E274			
MG75A0564	P13	F336	MG75A5454	P13	F311			
MG75A0572	P03	A09	MG75A5956	P11	E280			
MG75A0601	P19	J471	MG75A6454	P13	F314			
MG75A0602	P09	D205	MG75A6956	P13	F307			
MG75A0603	P09	D223	MG75A7454	P13	F324			
MG75A0631	P09	D233	MG75A7956	P13	F322			
MG75A0660	P05	B072	MG75A8454	P13	F327			
MG75A0664	P05	B073	MG75A8956	P13	F326			
MG75A0682	P19	J509	MG75A9454	P15	G375			
MG75A0691	P03	A05	MG75E0139	P23	L919			
MG75A0708	P13	F342	MG75E0210	P03	A902			
MG75A0724	P23	L597	MG75E0230	P05	B112			
MG75A0729	P13	F318	MG75E0252	P15	G371			
MG75A0738	P15	G368	MG75E0253	P15	G372			
MG75A0750	P13	F340	MG75E0279	P07	C145			
MG75A0763	P13	F325	MG75E0321	P09	D207			
MG75A0765	P13	F329	MG75E0383	P05	B083			
MG75A0776	P23	L578	MG75E0454	P13	F331			
MG75A0780	P21	K544	MG75E0463	P13	F304			
MG75A0830	P03	A59	MG75E0464	P11	E260			
MG75A0841	P09	D234	MG75E0465	P11	E272			
MG75A0880	P03	A04	MG75E0470	P03	A901			
MG75A0910	P09	D216	MG75E0492	P05	B089			
MG75A0950	P11	E278	MG75E0534	P19	J914			
MG75A0956	P05	B090	MG75E0564	P13	F309			
MG75A0977	P21	K527	MG75E0580	P05	B904			
MG75A1139	P23	L607	MG75E0633	P09	D228			
MG75A1148	P21	K522	MG75E0635	P09	D243			
MG75A1286	P13	F302	MG75E0640	P09	D910			
MG75A1392	P23	L588	MG75E0682	P19	J916			
MG75A1454	P07	C143	MG75E0688	P21	K523			
MG75A1460	P07	C181	MG75E0693	P05	B091			
MG75A1476	P09	D214	MG75E0731	P21	K536			

三菱電機株式会社

お問い合わせは下記へどうぞ

FAシステム事業本部 機器計画部 駆動機器グループ 〒100-8310 東京都千代田区丸の内 2-7-3 (東京ビル)

代表電話番号 (03)3218-6631 代表FAX番号 (03)3218-6823

MITSUBISHI ELECTRIC CORPORATION

FACTORY AUTOMATION SYSTEM GROUP

Tokyo 100-8310, Japan

Fax : +81-3-3218-6821