

mitsubishi

三菱工業用ミシン部品カタログ

Industrial Sewing Machine Parts Catalog

Model PLK E2516 YU

目次	CONTENTS	Page
A 本体構成	Construction	1
B 本体関係 (1)	Arm bed & it's accessories (1)	2
C 本体関係 (2)	Arm bed & it's accessories (2)	4
D 本体関係 (3)	Arm bed & it's accessories (3)	6
E 縫い機構 (1)	Sewing mechanism (1)	8
F 縫い機構 (2)	Sewing mechanism (2)	10
G 中押え機構	Presser bar lifting mechanism	12
H 糸切り機構	Thread trimming mechanism	14
J X - Y テーブル機構	X-Y table mechanism	16
K 外押え機構 (1)	Work holder mechanism (1)	18
L 外押え機構 (2)	Work holder mechanism (2)	20
M ワイパー機構	Wiper mechanism	22
N 給油機構	Oil lubrication mechanism	24
P 配線・配管関係	Cable component & Pneumatic control unit	26
Q テーブル関係	Table & Stand	28
R 付属品 (1)	Accessories (1)	30
S 付属品 (2)	Accessories (2)	32
T オプションパーツ	Option parts	34
索引	Index	36

部品コードの採番形式

MITSUBISHI SPARE PARTS No. Designation system

1. 部品コードについて CONCERNING PARTS CODE.

部品をご注文される場合は、部品コードをお知らせください。

Please inform the part number, when these parts are ordered.

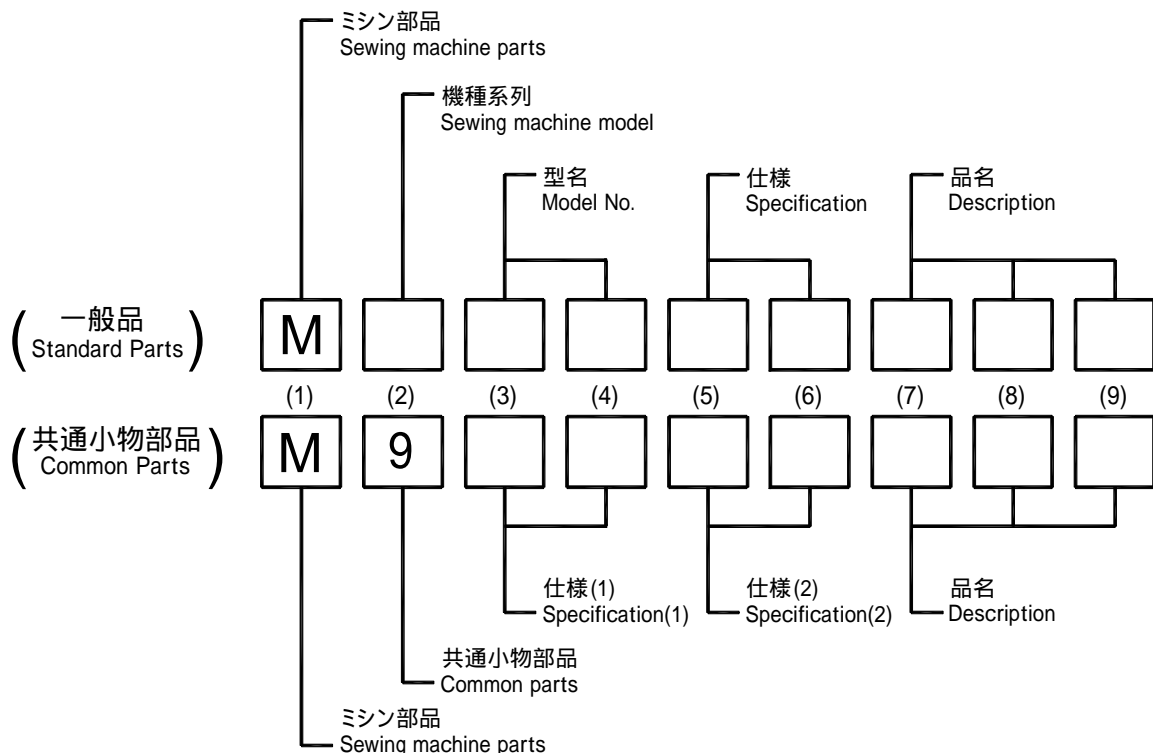

【 例 Example 】

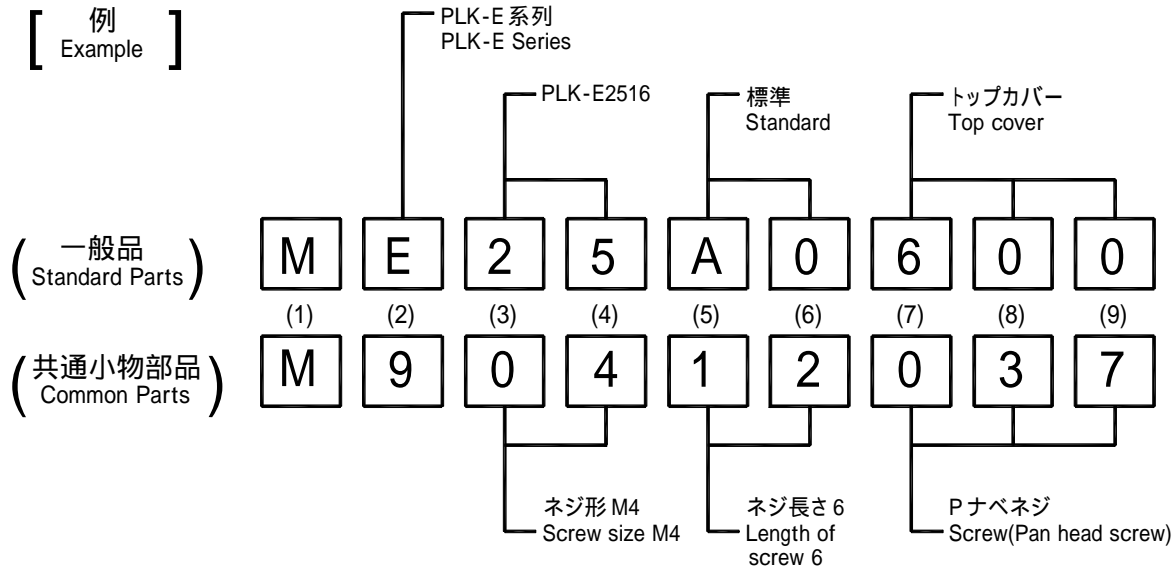

2. 変更マークについて CONCERNING MODIFICATION MARK.

変更マーク欄に*記号のある部品は、形状、寸法などの変更履歴がありますので、ご注文の際にはご使用の製品の製造番号と合わせてご覧ください。

The parts marked with * in the modification column has been changed the shape or size etc. So when these modified parts are ordered please inform the serial number of the sewing machine.

注：一般品についての機種型名は、その部品が最初に使用された機種型名を示します。

従って長期にわたる場合は、機種の変更が行われるため、当初の機種以外の機種で使用されている場合があります。

Sewing machine Models, of Standard Parts are Indicated model of these parts are registered firstly. Parts are used for not only the indicated model, but also another models, in reason of New development, improvement after.

A 全体構成
CONSTRUCTION

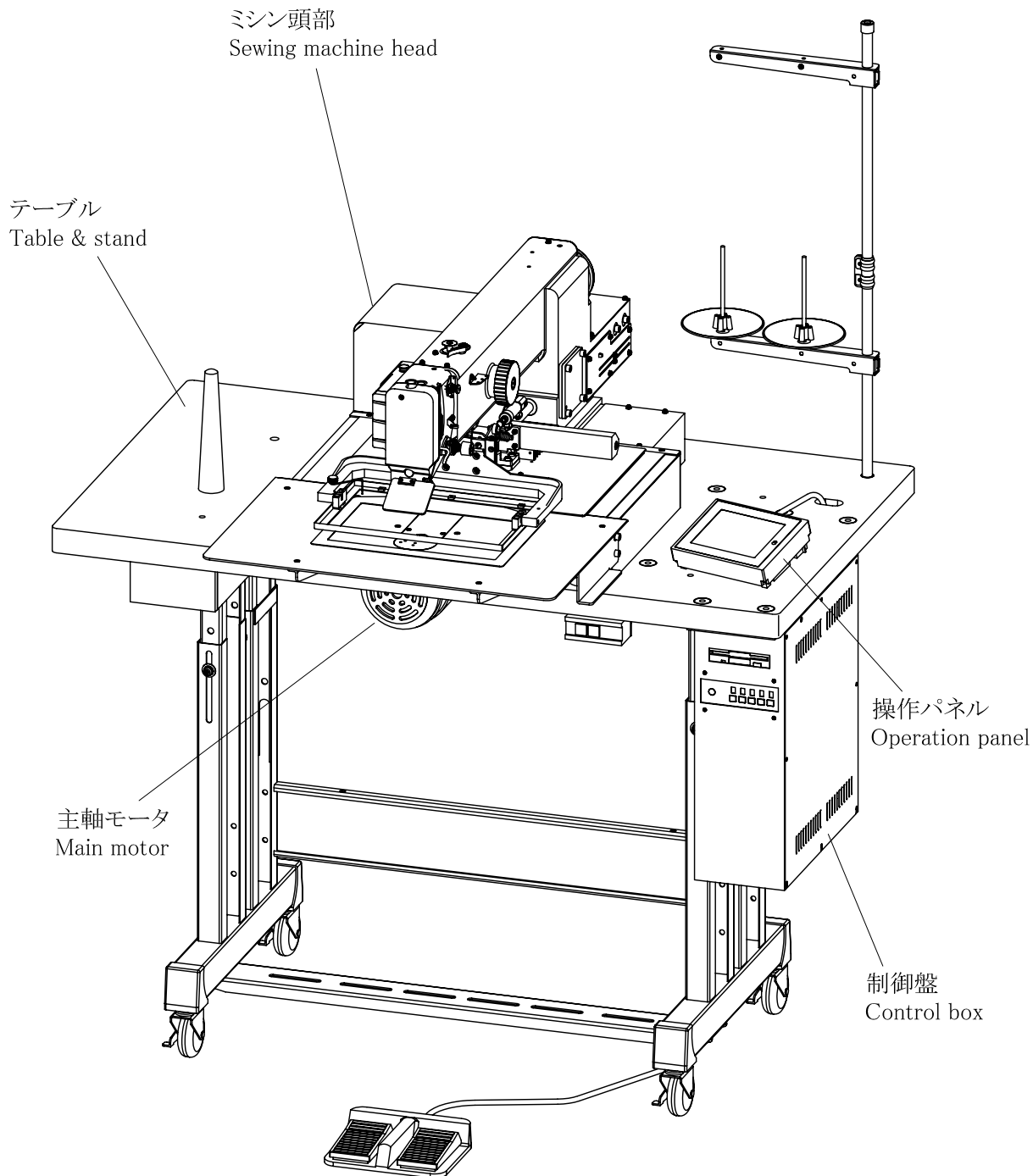

注1：モータ部分は三菱リミサーボX部品カタログを参照ください。

注2：Fig.No.の採番していない部品は単体で支給することは出来ません。Setにて支給いたします。

Remarks 1) Concerning about the motor parts please refer to the parts catalog of MITSUBISHI LIMISERVO X.

Remarks 2) The parts which Fig.No are not marked are not available individually. It can be supplied with the whole component.

B 本体関係(1)
 ARM BED & IT'S ACCESSORIES(1)

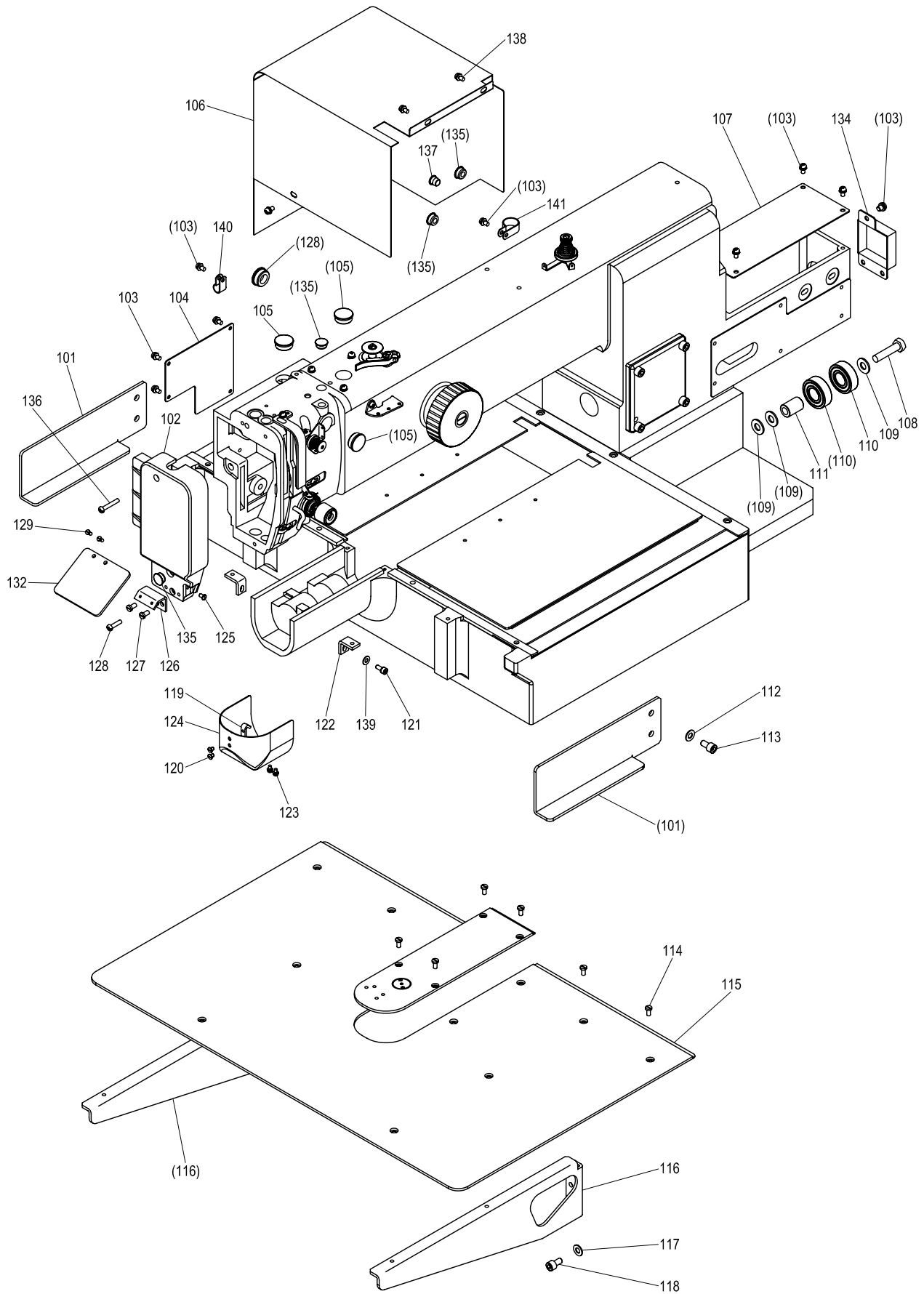

[B] 本体関係(1)
ARM BED & IT'S ACCESSORIES(1)

Fig no.	変更 Mod.	部品コード Parts no.	品 名	Description	数量 Amt. Req.
B 101		MB61A0601	トリツケイタ	Holder	2
B 102		ME10E1830	メンイタ	Face cover	1
B 103		M91054004	SW-PWブラマイナヘネジ M4X8	Screw M4X8	16
B 104		ME10A0742	フタ	Cover	1
B 105		M91910080	ゴムセン 19	Rubber plug 19	4
B 106		MB62E0849	モータカバー	Motor cover	1
B 107		MB62A0339	カバー	Cover	1
B 108		M91803022	ロツカアナツキボルト M8X40	Bolt M8X40	1
B 109		M90823050	ミガキザガネ 8	Washer 8	3
B 110		MS10A1456	シクウケ 6202ZZ	Bearing 6202ZZ	2
B 111		MB60A0750	ブッシュ	Bushing	1
B 112		M90631050	ザガネ 6	Washer 6	4
B 113		M96002017	セフテソケット M6X12	Bolt M6X12	4
B 114		M90990002	ヒラネジ M4X8	Screw M4X8	12
B 115		ME25Y0470	スハリイタ	Slide plate	1
B 116		MB25A0426	ササエカナゲ	Support	2
B 117		M90511050	ザガネ 5	Washer 5	6
B 118		M95002017	セフテソケット M5X12	Bolt M5X12	6
B 119		MS01A0361	カケガネ	Latch	1
B 120		M90906003	マルヒラネジ 9/64(40)X3.2	Screw 9/64(40)X3.2	2
B 121		M94001017	セフテソケット M4X10	Bolt M4X10	2
B 122		MB62A4601	トリツケイタ	Bracket	2
B 123		M90859004	SW-PWブラマイナヘネジ M3X6	Screw M3X6	2
B 124		ME10B0339	シリンダカバー	Cylinder cover	1
B 125		M90909003	マルヒラネジ 9/64(40)X6	Screw 9/64(40)X6	1
B 126		MB60A0601	アイガードトリツケイタ	Eye guard bracket	1
B 127		M91110002	ヒラネジ 11/64(40)X8	Screw 11/64(40)X8	2
B 128		M91057004	SW-PWブラマイナヘネジ M4X20	Screw M4X20	1
B 129		M90806002	ヒラネジ 1/8(44)X6	Screw 1/8(44)X6	2
B 132		MS01A0160	アイガード	Eye guard	1
B 134		ME26C0339	カバー	Cover	1
B 135		M91182080	ゴムセン 11.8	Rubber plug 11.8	4
B 136		M91066004	SW-PWブラマイナヘネジ M4X25	Screw M4X25	1
B 137		M90883080	ゴムセン 8.8	Rubber plug 8.8	1
B 138		M91071004	SW-MWブラマイナヘネジ M4X8	Screw M4X8	3
B 139		M90421050	ザガネ 4	Washer 4	2
B 140		MN60A0620	ナイロンクリップ AB-5N	Nylon clip AB-5N	5
B 141		MB60A2620	ナイロンクリップ AB-10N	Nylon clip AB-10N	1

C 本体関係(2)
 ARM BED & IT'S ACCESSORIES(2)

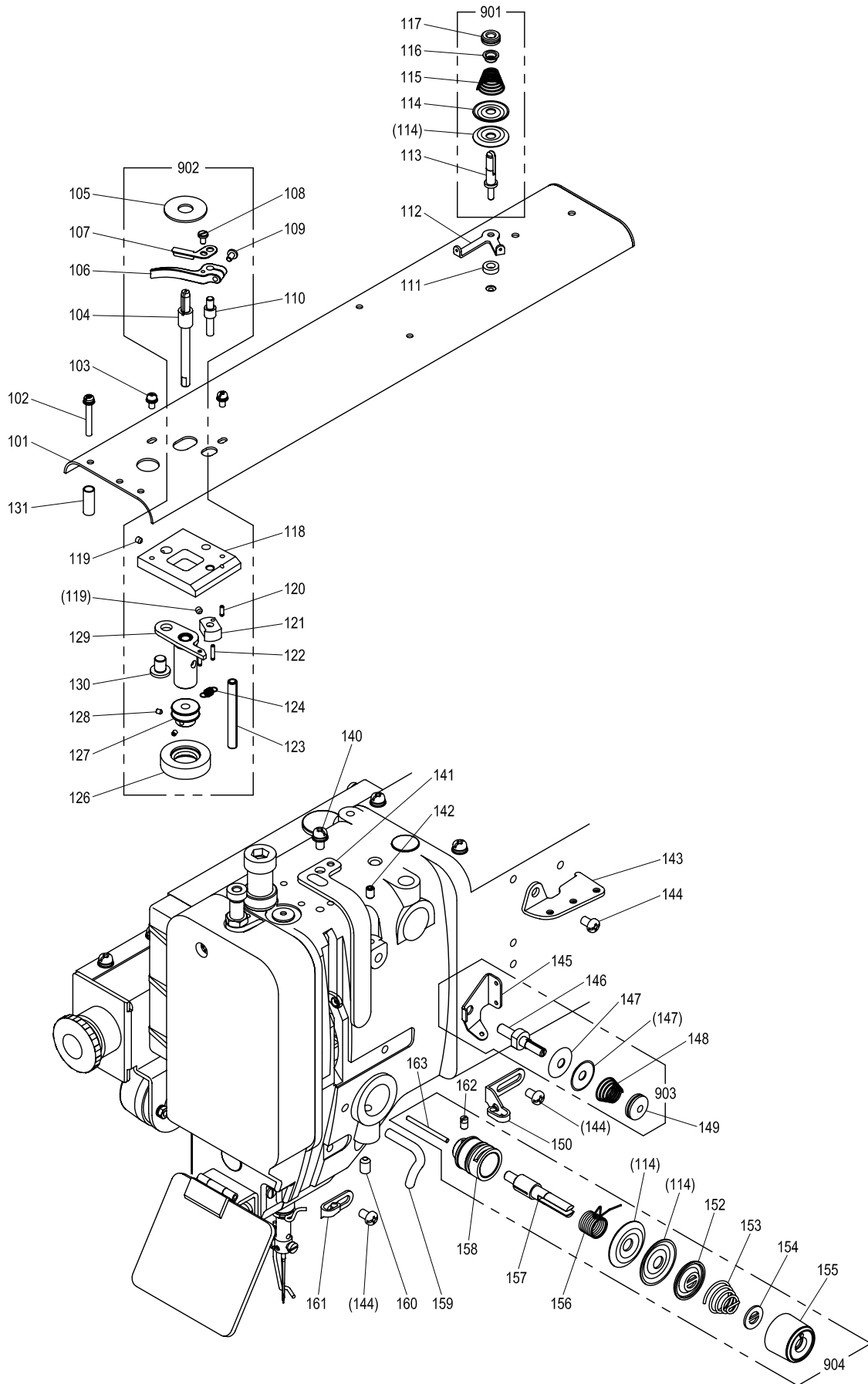

[C] 本体関係(2)
ARM BED & IT'S ACCESSORIES(2)

Fig no.	変更 Mod.	部品コード Parts no.	部品名	Description	数量 Amt. Req.
C 101		ME25A0600	トップカバー	Top cover	1
C 102		M91276004	SW-PWブラマイナヘネジ M4X30	Screw M4X30	5
C 103		M91013004	SW-MWブラマイナヘネジ M4X10	Screw M4X10	2
C 104		MA04A1530	ダンツキジク D	Driven shaft	1
C 105		MA20A0476	スパーサー	Spacer	1
C 106		ME25A0950	レバー	Lever	1
C 107		ME25A0551	チョウセツイタ	Adjuster plate	1
C 108		M90920002	ヒラネジ 9/64(40)X6.5	Screw 9/64(40)X6.5	1
C 109		M90939002	ヒラネジ 9/64(40)X11	Screw 9/64(40)X11	1
C 110		ME25A0530	ダンツキジク	Shaft	1
C 111		MG75A1476	スパーサー	Spacer	1
C 112		MS14A1180	イトアンナイ	Thread guide	1
C 113		MS14A0553	チョウシホウ	Thread tension stud	1
C 114		MF10A0555	チョウシガラ	Thread tension discs	4
C 115		MM11A0245	エンスイバネ	Thread tension spring	1
C 116		MM11A0702	バネアンナイ	Spring guide	1
C 117		M91602046	ツミナット	Thumb nut	1
C 118		MB60A1601	トリツケイタ	Bracket	1
C 119		M91055020	ロツカクアナツキトメネジ M4X4	Screw M4X4	2
C 120		M91004067	ミツツキピン BXガタ 2.5X8	Pin 2.5X8	1
C 121		MS14A0350	カム	Cam	1
C 122		M91005067	ミツツキピン BXガタ 2.5X12	Pin 2.5X12	2
C 123		M90601064	スプリングピン 6X56	Pin 6X56	1
C 124		MS14A0572	ツルマキバネ	Spring	1
C 126		MS03A0417	ゴムワ	Tire	1
C 127		MA20A0194	イトマキグルマ	Wheel	1
C 128		M91057020	ロツカクアナツキトメネジ M3X4	Screw M3X4	2
C 129		MB60E2750	レバークミタテ	Lever	1
C 130		M99006063	ピン	Pin	1
C 131		MB62A0352	スパーサー 1382312-60200	Spacer	5
C 140		M91054004	SW-PWブラマイナヘネジ M4X8	Screw M4X8	1
C 141		MA20A0584	テンピンカバー	Thread take-up lever guard	1
C 142		M91053020	ロツカクアナツキトメネジ M4X6	Screw M4X6	1
C 143		MF36A1180	イトアンナイ	Thread guide	1
C 144		M91011004	ブラマイナヘネジ M4X6	Screw M4X6	3
C 145		MF00A0181	イトアンナイ	Thread guide	1
C 146		MF90A0553	チョウシホウ	Thread tension stud	1
C 147		MF10A1555	チョウシガラ	Thread tension discs	2
C 148		MF36A0245	エンスイバネ	Thread tension spring	1
C 149		M91101046	ツミナット	Thumb nut	1
C 150		MG43A0181	イトアンナイ	Thread guide	1
C 152		MM11A0556	チョウシガラオサエ	Disc retaining plate	1
C 153		MN52A1245	エンスイバネ	Thread tension spring	1
C 154		MT60A0802	マワリトメ	Thumb nut revolution stopper	1
C 155		M91610046	ツミナット	Thumb nut	1
C 156		MF10A0187	イトトリバネ	Thread take-up spring	1
C 157		MF10A0553	チョウシホウ	Thread tension stud	1
C 158		MF10A0709	ブッシュ	Regulator casing	1
C 159		MF70A1180	イトアンナイ	Thread guide	1
C 160		M95004020	ロツカクアナツキトメネジ M5X8	Screw M5X8	1
C 161		MF10A0181	イトアンナイ	Thread guide	1
C 162		M90901002	ヒラネジ 9/64(40)X4	Screw 9/64(40)X4	1
C 163		M90204060	ピン	Pin	1
C 901		MS14E0180	チョウセツキクミタテ	Thread tension Regulator assy	1
C 902		ME25E0190	イトマキソウチクミタテ	Bobbin winder	1
C 903		MF00E0550	チョウセツキクミタテ	Thread tension Regulator assy	1
C 904		MA16E0210	チョウセツキクミタテ	Thread tension Regulator assy	1

D 本体関係(3)
ARM BED & IT'S ACCESSORIES(3)

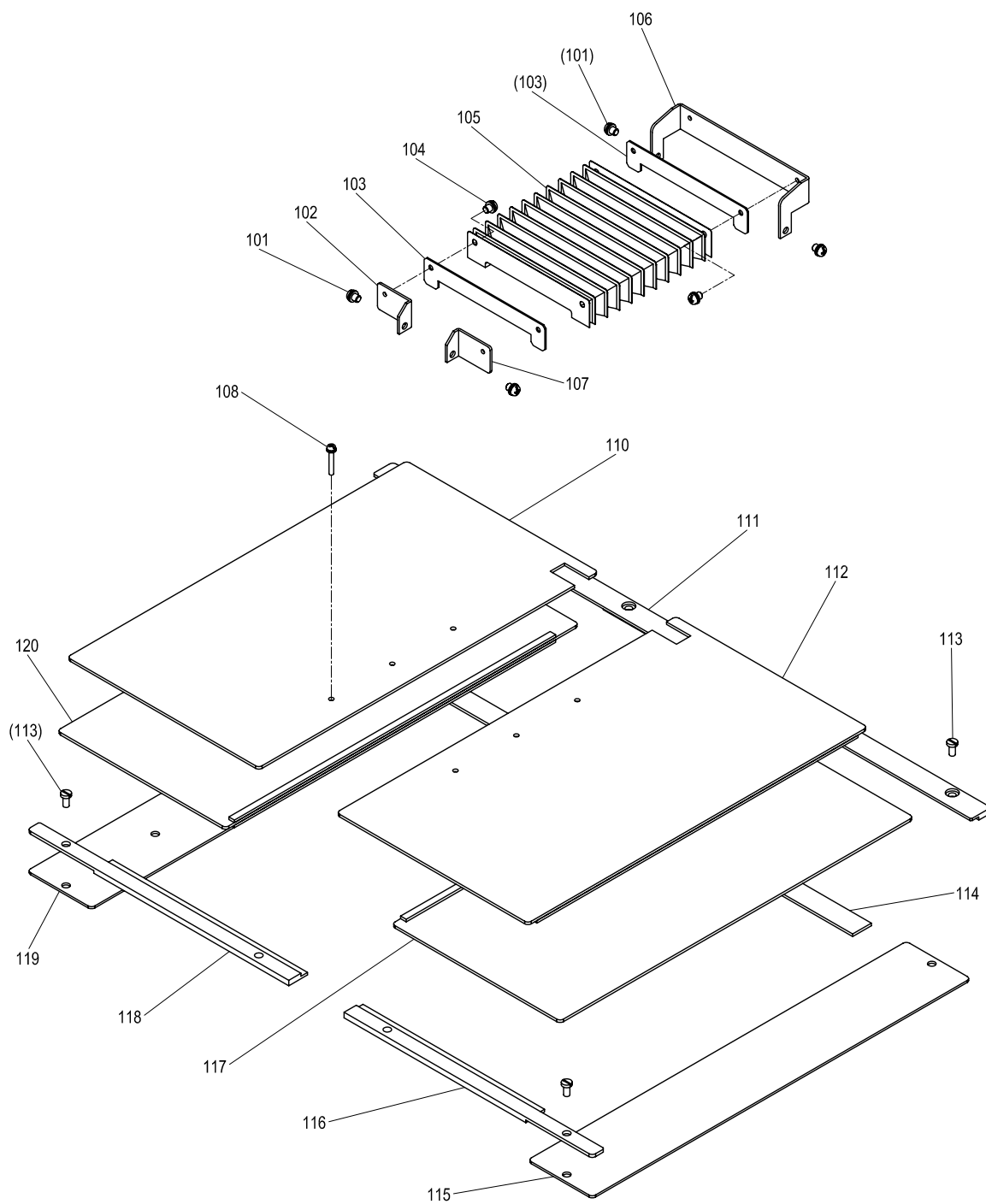

[D] 本体関係(3)

ARM BED & IT'S ACCESSORIES(3)

Fig no.	変更 Mod.	部品コード Parts no.	品 名	Description	数量 Amt. Req.
D 101		M91058004	SW-PWブラマイナヘネジ M4X6	Screw M4X6	4
D 102		MB62A1601	シャッターリツケイタ (B)	Shutter adapter (B)	1
D 103		MA20A0257	オサエイタ	Shutter holder	2
D 104		M90859004	SW-PWツキブラマイネジ M3X6	Screw M3X6	4
D 105		MA20A0458	シャッター	Shutter	1
D 106		MB60A8601	シャッターリツケイタ	Shutter adapter	1
D 107		MB62A0601	シャッターリツケイタ (A)	Shutter adapter (A)	1
D 108		M90359037	Pサラネジ	Screw M3X16	6
D 110		ME25Y0339	Xカバーイタ (ヒダリ)	X-cover plate (left)	1
D 111		MB62A2359	カバーガイド (ミキ)	Cover guide (right)	1
D 112		ME25Y1339	Xカバーイタ (ミキ)	X-cover plate (right)	1
D 113		M90990002	ヒラネジ M4X8	Screw M4X8	8
D 114		MB62A1352	スペーサ	Spacer	1
D 115		ME25Y2339	X-Yカバー (ヒダリ)	X-Y cover cover (left)	1
D 116		MB62A5352	スペーサ (ミキ)	Spacer (right)	1
D 117		ME25Y3339	Xイドウカバー	X-movable cover	1
D 118		MB62A6352	スペーサ (ヒダリ)	Spacer (left)	1
D 119		MB62A6339	X-Yカバー (ミキ)	X-Y cover (right)	1
D 120		ME25Y3339	Xイドウカバー	X-movable cover	1

E 縫い機構(1)
SEWING MECHANISM(1)

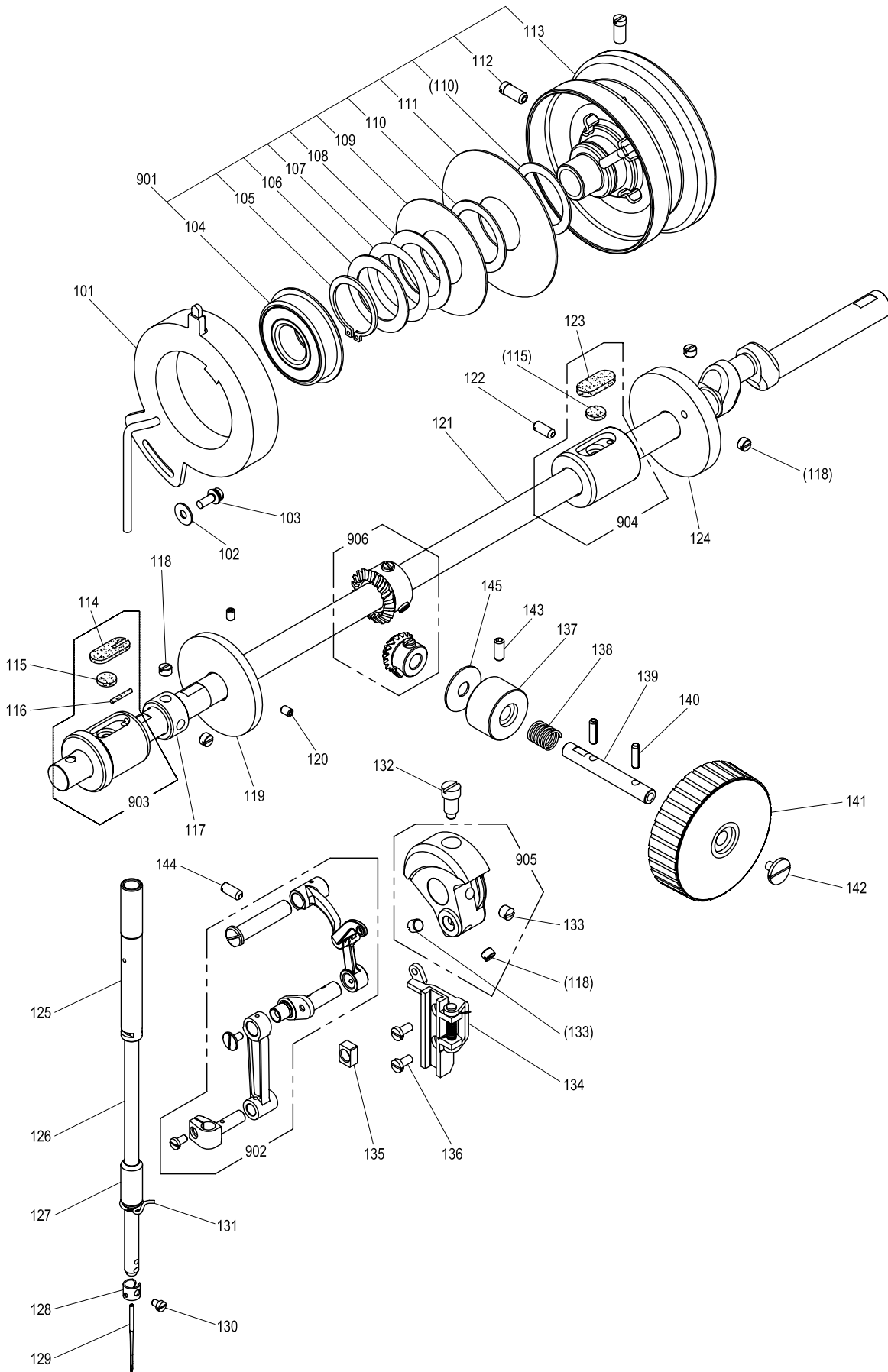

[E]縫い機構(1)
SEWING MECHANISM(1)

Fig no.	変更 Mod.	部品コード Parts no.	品名	Description	数量 Amt. Req.
E 101		ME20A0406	ウワジクケンシュツキ	Detector	1
E 102		M90421050	ザガネ 4	Washer 4	1
E 103		M91059004	SW-PWプラマイナヘネジ M4X12	Screw M4X12	1
E 104		MN10A1456	ボールベアリング	Ball bearing	1
E 105		M90330065	Cガタメワ 30	C-type retaining ring 30	1
E 106		M93001050	ザガネ	Washer	1
E 107		MF01A0259	ナミザガネ	Wave washer	1
E 108		MF01A1476	スヘーサー B	Spacer B	1
E 109		MN72A1694	ハンジヤパン F20 (ウワイチ)	Command disk F20 (up)	1
E 110		MF01A0476	スヘーサー A	Spacer A	2
E 111		MB60A0694	ハンジヤパン K10 (シタイチ)	Command disk K10 (down)	1
E 112		M91520002	ヒラネジ 15/64(28)X12	Screw 15/64(28)X12	2
E 113		MB60E0682	プーリ	Pulley	1
E 114		MG50A0740	フェルト	Felt	1
E 115		MS10A1740	フェルト	Felt	2
E 116		MV88A0740	フェルト	Felt	1
E 117		MF80A0352	カラー	Collar	1
E 118		M91602001	トメネジ 1/4(40)X4	Screw 1/4(40)X4	5
E 119		MS14A0682	イトマキプーリ	Pulley	1
E 120		M91053020	ロツカクアナツキトメネジ M4X6	Screw M4X6	2
E 121		ME25A0230	ウワジク	Drive shaft	1
E 122		M95003001	トメネジ M5X12	Screw M5X12	1
E 123		MF60A2740	フェルト	Felt	1
E 124		ME25Y0350	イトキリカム	Thread trimmer cam	1
E 125		MS01A0663	ハリホウメタル (ウエ)	Needle bar bushing (upper)	1
E 126		MS01A0660	ハリホウ	Needle bar	1
E 127		MG30A0664	ハリホウメタル (シタ)	Needle bar bushing (lower)	1
E 128		MF21D0181	イトアンナイ	Thread guide	1
E 129		MS02A0128	ミシンハリ DPX17#18	Needle DPX17#18	1
E 130		M90815002	ヒラネジ 1/8(44)X4.5	Screw 1/8(44)X4.5	1
E 131		MF01A0181	イトアンナイ	Thread guide	1
E 132		M91802006	ヒラネジ ホウサキ 9/32(28)	Set screw 9/32(28)	1
E 133		M91606001	トメネジ 1/4(40)X6	Screw 1/4(40)X6	2
E 134		MS03E0662	ハリカガイドクミタテ	Guide assy	1
E 135		MF10A0325	カクコマ	Square block	1
E 136		M90990002	ヒラネジ M4X8	Screw M4X8	2
E 137		ME25A1833	メタル	Bushing	1
E 138		MA35A2572	ツルマキハネ	Spring	1
E 139		ME25A0454	ジク	Shaft	1
E 140		M90406064	スプリングピン 4X14	Pin 4X14	2
E 141		ME25A0682	テマワシプーリ	Hand pulley	1
E 142		M91119002	ヒラネジ	Screw M4X8	1
E 143		M95006020	ロツカクアナツキトメネジ M5X12	Screw M5X12	1
E 144		M95003001	トメネジ M5X12	Screw M5X12	1
E 145		ME25A0416	カンショウゴム	Rubber	1
E 901		MB60E1682	プーリクミタテ	Pulley assy	1
E 902		MS01E0580	テンピンハリクミタテ	Thread take-up lever assy	1
E 903		MS10A0232	ウワジクメタル(ヒダリ)カミ	Drive shaft bushing L assy	1
E 904		MB60E0234	ウワジクメタル(ナカ)カミ	Drive shaft bushing C assy	1
E 905		MS01A0383	クランクカミ	Crank assy	1
E 906		ME25E0331	カサハグルマカミ	Bevel gear assy	1

F 縫い機構(2)
SEWING MECHANISM(2)

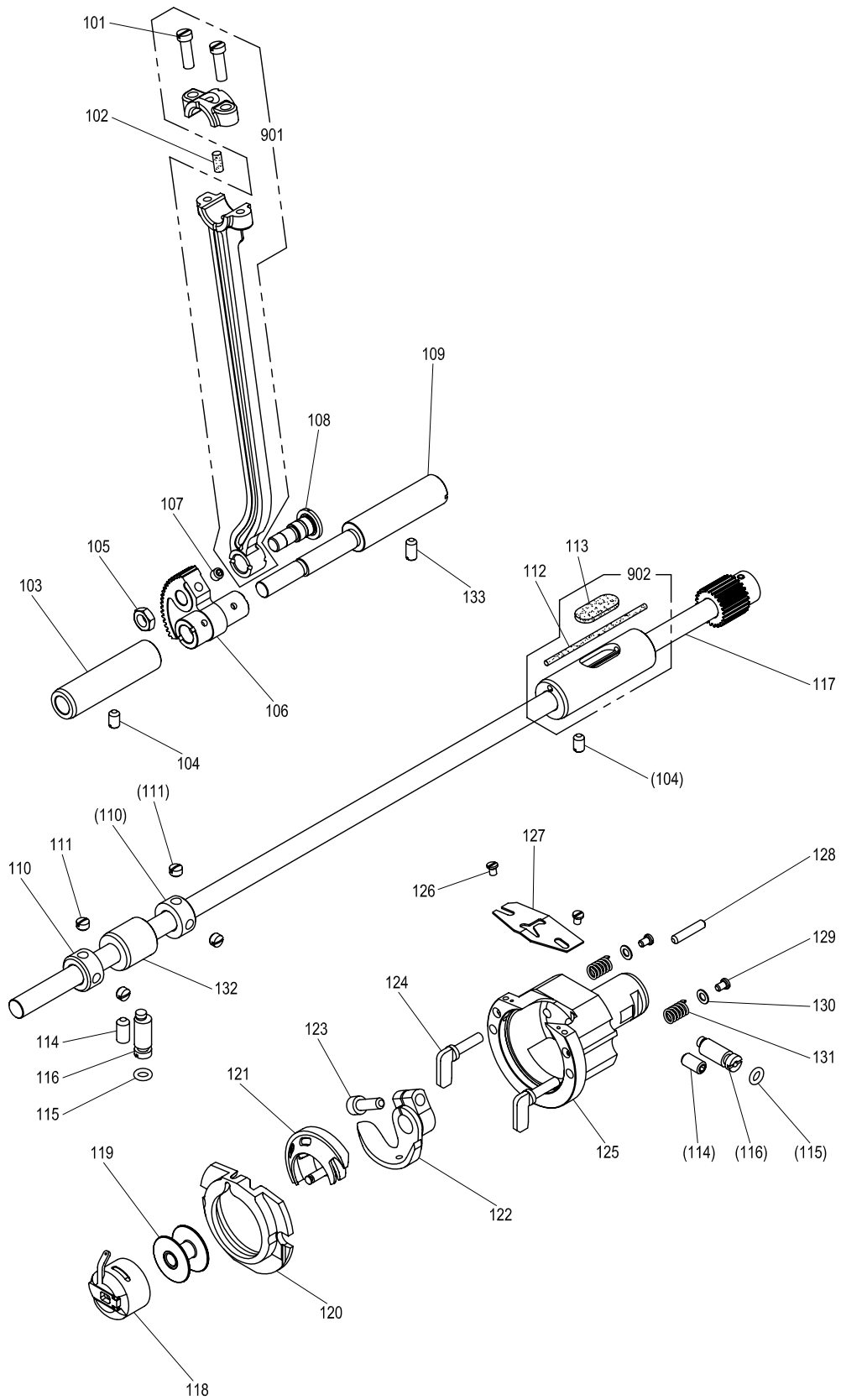

[F] 縫い機構(2)
SEWING MECHANISM(2)

Fig no.	変更 Mod.	部品コード Parts no.	品名	Description	数量 Amt. Req.
F 101		M91203002	ヒラネジ' 3/16(28)X15	Screw 3/16(28)X15	2
F 102		MB60A0740	フェルト	Felt	1
F 103		ME10A0833	メタル	Bushing	1
F 104		M95002001	スリワリトメネジ' M5X6	Screw M5X6	1
F 105		M91802045	ナット 9/32(28)	Nut 9/32(28)	1
F 106		MS01A0508	セクタハグルマ	Sector gear	1
F 107		M95004021	ロッカアナツキトメネジ' M5X5	Screw M5X5	1
F 108		M98003015	ヒラネジ' ダンツキ 9/32(28)	Screw 9/32(28)	1
F 109		MS01A0891	ヨウトウジク	Rock shaft	1
F 110		MM11A0352	カラ	Collar	2
F 111		M91503001	トメネジ' 15/64(28)X4.5	Screw 15/64(28)X4.5	4
F 112		ME10A0148	ヒモ	Oil braid	1
F 113		MA20A0740	フェルト	Felt	1
F 114		M96002020	ロッカアナツキトメネジ' M6X12	Screw M6X12	2
F 115		M90500085	Oリング	O-ring	2
F 116		ME25Y0760	ハンジンジク	Eccentric shaft	2
F 117		MB62E0450	シタジククミ	Hook shaft assy	1
F 118		MS17A0125	ホビンケース SC-181	Bobbin case	1
F 119		MA10A0123	ホビン	Bobbin	1
F 120		MS08A0616	ナカガマオサエ	Hook retainer	1
F 121		MA10A0120	ナカガマ	Inner hook	1
F 122		MS01A0611	ドライバ	Hook driver	1
F 123		M95001021	ロッカアナツキホルト M5X16	Bolt M5X16	1
F 124		MS09A0950	カマオサエツマミ	Hook clamp	2
F 125		MS01A0121	ソトガマ	Outer hook	1
F 126		M90853002	ヒラネジ' 1/8(40)X4	Screw 1/8(40)X4	2
F 127		MS01A0329	カマイトアンナイ	Thread guide	1
F 128		M90001060	ヘイコウピン M6-4X18	Pin M6-4X18	1
F 129		M90802003	マルヒラネジ' 1/8(44)X4.5	Screw 1/8(44)X4.5	2
F 130		M90323050	ザガネ	Washer	2
F 131		MS01A0572	ツルマキハネ	Spring	2
F 132		MB62A1453	シタジクメタル (ナカ)	Hook shaft bushing (C)	1
F 133		M95003001	スリワリトメネジ' M5X12	Screw M5X12	1
F 901		MB62E0956	レンセツカン クミ	Connecting rod assy	1
F 902		ME10E0452	シタジクメタル(ミギ)クミ	Hook shaft bushing (R) assy	1

G 中押え機構
PRESSER BAR LIFTING MECHANISM

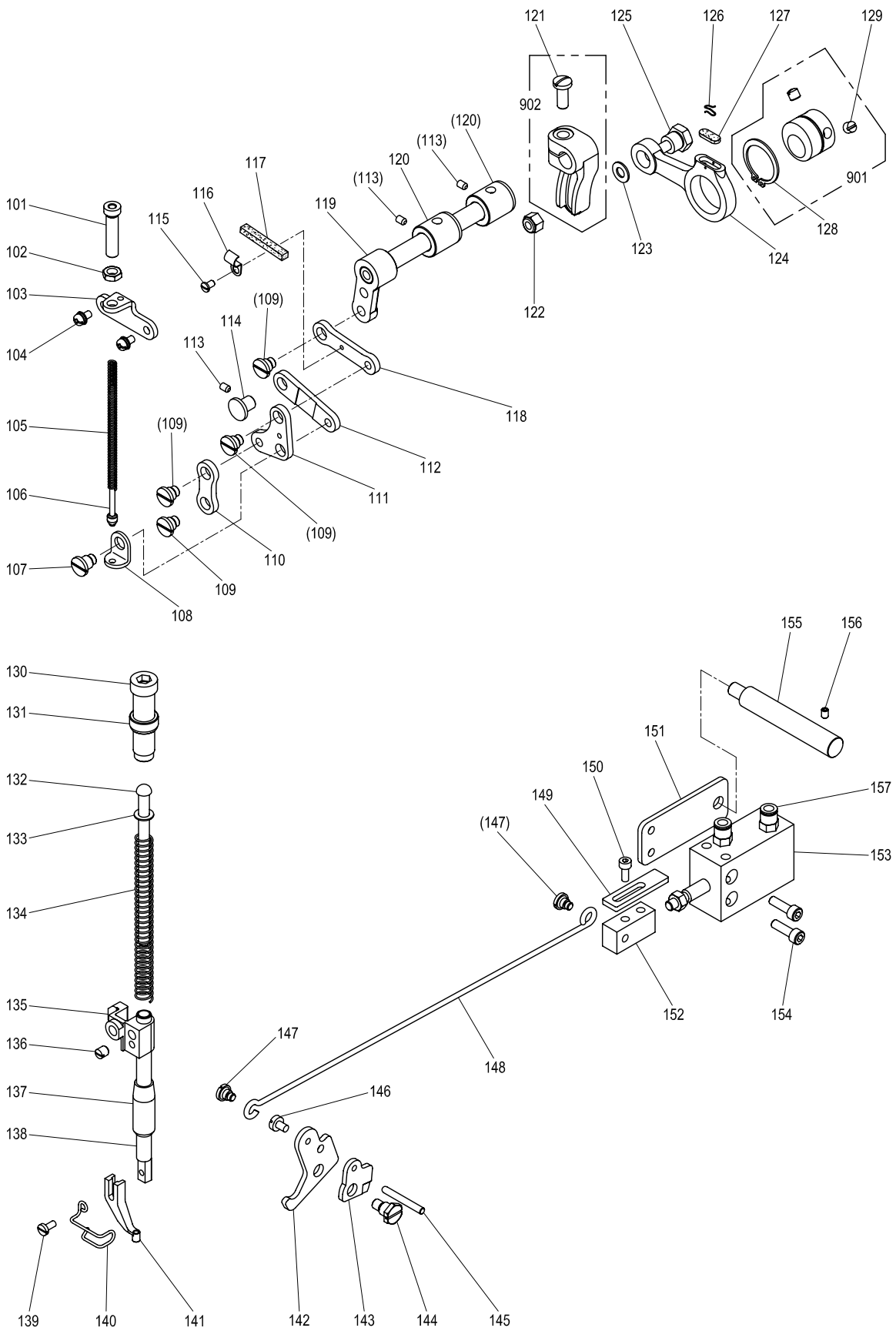

[G] 中押え機構

PRESSER BAR LIFTING MECHANISM

Fig no.	変更 Mod.	部品コード Parts no.	品名	Description	数量 Amt. Req.
G 101		M91801035	ツマミネジ 9/32(28)X35	Thumb screw 9/32(28)X35	1
G 102		M91802045	ナット 9/32(28)	Nut 9/32(28)	1
G 103		ME10A0261	オサエジョウセツガイ	Bracket	1
G 104		M91056004	SW-PWブラマイナヘネジ M4X10	Screw M4X10	2
G 105		ME10A0572	ツルマキハネ	Spring	1
G 106		MS03A6154	アンナイガネ	Spring guide bar	1
G 107		M91689015	ヒラネジダツキ 1/4(40)	Screw 1/4(40)	1
G 108		MG30B0226	オサエイタササエ	Supporter	1
G 109		M91688015	ヒラネジダツキ 1/4(40)	Screw 1/4(40)	4
G 110		ME10A6910	リンク	Link	1
G 111		ME10A0763	ベルクランク	Bell crank	1
G 112		ME10A7910	リンク	Link	1
G 113		M91058020	ロッカクアナツキトメネジ M4X10	Screw M4X10	3
G 114		M99006063	ツバツキジク	Pin	1
G 115		M90909003	マルヒラネジ 9/64(40)X6	Screw 9/64(40)X6	1
G 116		MN70A1780	ホルダ	Holder	1
G 117		MG30A0740	フェルト	Felt	1
G 118		ME10A1956	レンセツカン	Link	1
G 119		MS02E0460	ウデクミタテ	Arm shaft assy	1
G 120		MG30A0833	メタル	Bushing	2
G 121		M91603003	マルヒラネジ 1/4(40)X16	Screw 1/4(40)X16	1
G 122		M91572045	U ナット 6X0.75	U-nut 6X0.75	1
G 123		M90631050	ザガネ 6	Washer 6	1
G 124		ME10A0956	レンセツカン	Crank rod	1
G 125		M91551015	ホルトダツキ M6	Bolt M6	1
G 126		MF60A0700	センサイクハネ	Holder	1
G 127		MG30B0740	フェルト	Felt	1
G 128		M90325065	Cガタメワ 25	C-type retaining ring 25	1
G 129		M91606001	トメネジ 1/4(40)X6	Screw 1/4(40)X6	2
G 130		M93220035	ツマミネジ 1/2(28)X43	Thumb screw 1/2(28)X43	1
G 131		M93202047	ナット 1/2(28)	Nut 1/2(28)	1
G 132		MS03A0703	アンナイホウ	Presser bar guide	1
G 133		M90632050	コザガネ 6	Washer 6	1
G 134		MS03A1572	ツルマキハネ	Spring	1
G 135		MG75A0265	オサエホウダキ	Presser bar holder	1
G 136		M91506001	トメネジ 15/64(28)X6	Screw 15/64(28)X6	1
G 137		MF10A0267	オサエホウメタル	Bushing	1
G 138		MS03A0262	オサエホウ	Presser bar	1
G 139		M90922002	ヒラネジ 9/64(40)X8	Screw 9/64(40)X8	1
G 140		MB62A0626	ニードルガード	Needle guard	1
G 141		MV30A0256	オサエ 3	Presser foot 3	1
G 142		ME10A1252	オサエアゲレバ	Lifting lever	1
G 143		MF70A0350	イトユルメカム	Plate cam	1
G 144		M91504031	ホルト 15/64(28)	Bolt 15/64(28)	1
G 145		M90423060	イトユルピン	Pin	1
G 146		M91131002	ヒラネジ 11/64(40)X6.5	Screw 11/64(40)X6.5	1
G 147		M91219015	ヒラネジダツキ 3/16(28)	Screw 3/16(28)	2
G 148		ME25A0738	ヒキホウ	Link	1
G 149		ME25A0477	ストップ	Stopper	1
G 150		M95003017	セフティクェット M5X8	Bolt M5X8	2
G 151		ME25A0601	トリツケイタ	Adapter	1
G 152		ME25A0571	ジョイント	Joint	1
G 153		ME25A0434	エアシリンダ	Air cylinder	1
G 154		M95006017	セフティクェット M5X22	Bolt M5X22	2
G 155		ME25A1454	ジク	Shaft	1
G 156		M95004020	ロッカクアナツキトメネジ M5X8	Screw M5X8	1
G 157		ME40A0571	ワナタッチツギテ	Connector	2
G 901		MG30A0760	ハンソソリンクミタテ	Eccentric cam assy	1
G 902		MS02A0463	ウデ (ミキ)	Arm (right)	1

H 糸切り機構
THREAD TRIMMING MECHANISM

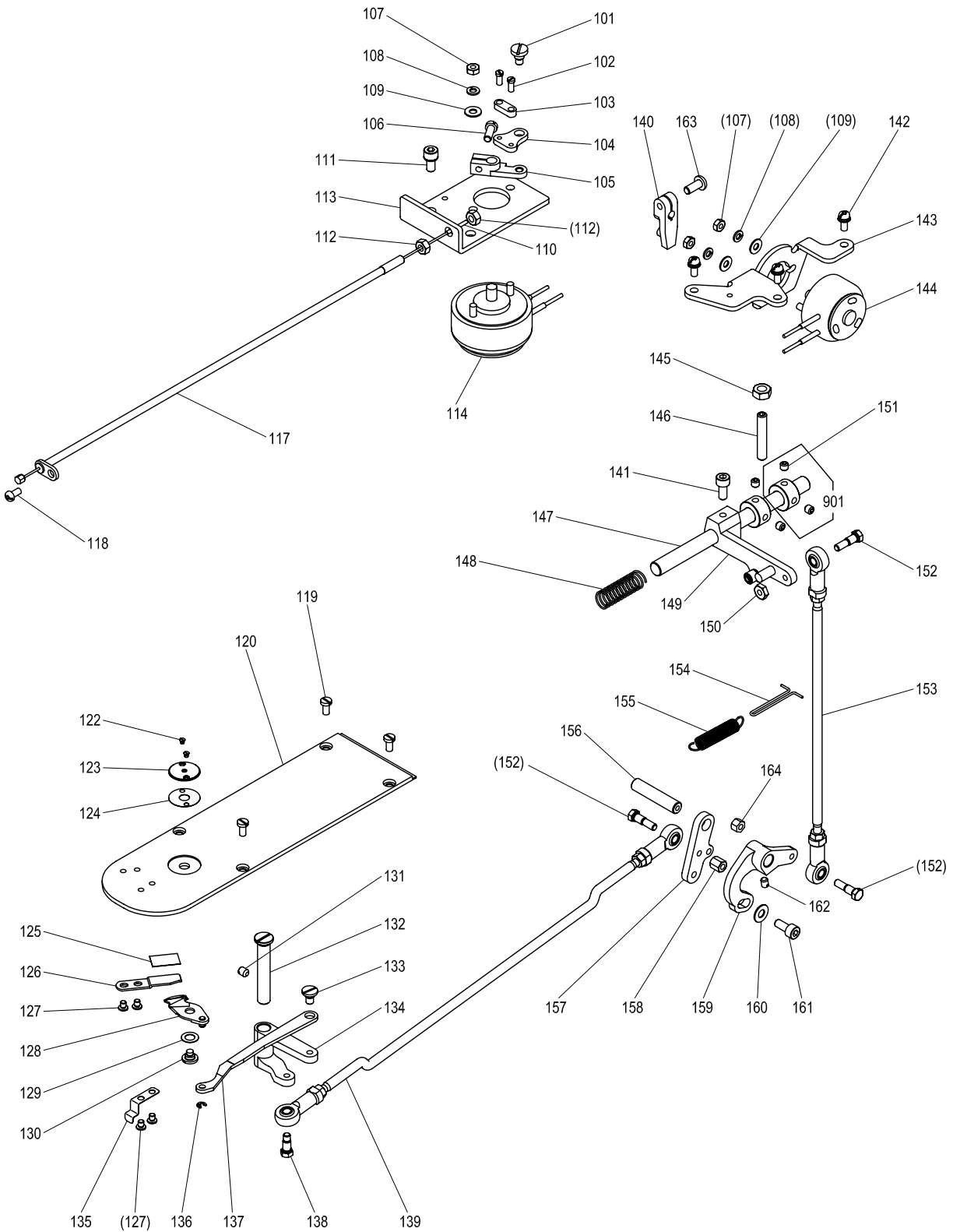

[H]系切り機構

THREAD TRIMMING MECHANISM

Fig no.	変更 Mod.	部品コード Parts no.	品名	Description	数量 Amt. Req.
H 101		M91127015	ヒラネジダツキ 11/64(40).....	Screw 11/64(40).....	1
H 102		M90825002	ヒラネジ 1/8(44)X10.....	Screw 1/8(44)X10.....	2
H 103		MF36A0750	ホルダ.....	Holder.....	1
H 104		MF90A0361	カケガネ.....	Bracket.....	1
H 105		MS07A0228	ウデ.....	Crank.....	1
H 106		M91112002	ヒラネジ 11/64(40)X12.....	Screw 11/64(40)X12.....	1
H 107		M91007045	ナット M4.....	Nut M4.....	4
H 108		M90424053	ハネサガネ 4.....	Spring washer 4.....	4
H 109		M90422050	サガネ 4.....	Washer 4.....	4
H 110		MN60A0750	プッシュ.....	Pipe.....	1
H 111		M95005017	セフティソケット M5X10.....	Bolt M5X10.....	2
H 112		M91382045	ナット M5.....	Nut M5.....	2
H 113		MA20A0603	ソレノイドトリツケイタ.....	Solenoid bracket.....	1
H 114		MB61E0519	イトコルメソレノイド.....	Solenoid (thread release).....	1
H 117		MA10E0746	フレキシブルワイヤ.....	Flexible wire assy.....	1
H 118		M91054004	プライマインハネジ M4X8.....	Screw M4X8.....	1
H 119		M90990002	ヒラネジ M4X8.....	Screw M4X8.....	4
H 120		ME26A0470	スベリイタ.....	Slide plate.....	1
H 122		M90605010	サラネジ 3/32(56)X2.8.....	Screw 3/32(56)X2.8.....	2
H 123		ME10A1101	ハリイタ 2.2.....	Needle plate.....	1
H 124		MS01A1476	スベサ.....	Spacer.....	1
H 125		MA10B2476	スベサ.....	Spacer.....	1
H 126		MS14A0838	コテメス.....	Fixed knife.....	1
H 127		M90906003	マルヒラネジ 9/64(40)X3.2.....	Screw 9/64(40)X3.2.....	4
H 128		ME03A0838	イドメス.....	Movable knife.....	1
H 129		M96004052	ウェーブワッシャ 6.....	Wave washer 6.....	1
H 130		M91129015	ヒラネジダツキ 11/64(40).....	Screw 11/64(40).....	1
H 131		M91224001	トメネジ M5X8.....	Screw M5X8.....	1
H 132		MB62A0454	ツバツキジク.....	Stepped pin.....	1
H 133		M91214015	ヒラネジダツキ 3/16(28).....	Screw 3/16(28).....	1
H 134		MA20A0392	メスカトウウテ (3).....	knife driving crank (3).....	1
H 135		MS01A0192	イタハネ.....	Leaf spring.....	1
H 136		M90513065	Eガタメリ 2.5.....	E-type retaining ring 2.5.....	1
H 137		MA20A1910	リンク.....	Link.....	1
H 138		M91101017	ボルトダツキ 11/64(40).....	Bolt 11/64(40).....	1
H 139		MB62E0975	ロッドエンドクミタテ (コ).....	Connecting rod (horizontal).....	1
H 140		MS01E0430	イタキリサドウウテ.....	Crank.....	1
H 141		M95003021	ロッカアナツキボルト M5X12.....	Bolt M5X12.....	1
H 142		M91056004	SW-PWプライマインハネジ M4X10.....	Screw M4X10.....	3
H 143		MS14A3601	ソレノイドトリツケイタ.....	Solenoid bracket.....	1
H 144		MB05E0519	イタキリソレノイド.....	Solenoid (thread trim).....	1
H 145		M91576045	ナット M6.....	Nut M6.....	1
H 146		M91652020	コネジ M6X35.....	Screw M6X35.....	1
H 147		MS01A0348	カムジク.....	Shaft.....	1
H 148		MS01A1572	ツルマキハネ.....	Spring.....	1
H 149		MS01E0351	カムツイジユウウテクミ.....	Cam follower assy.....	1
H 150		M91104045	ナット 11/64(40).....	Nut 11/64(40).....	1
H 151		M95004021	ロッカアナツキトメネジ M5X5.....	Screw M5X5.....	4
H 152		M90101017	ボルトダツキ 11/64(40).....	Bolt 11/64(40).....	3
H 153		ME25Y0975	ロッドエンドクミタテ (タテ).....	Connecting rod (vertical).....	1
H 154		MS08A0708	ハネカケ.....	Hook.....	1
H 155		MS01A2572	ツルマキハネ.....	Spring.....	1
H 156		MS08A0454	ジク.....	Shaft.....	1
H 157		MS01A2392	メスカトウウテ (2).....	knife driving crank (2).....	1
H 158		M91109045	ロングナット 11/64(40).....	Long nut 11/64(40).....	1
H 159		MS01A1392	メスカトウウテ (1).....	knife driving crank (1).....	1
H 160		M90511050	サガネ 5.....	Washer 5.....	1
H 161		M95002017	セフティソケット M5X12.....	Bolt M5X12.....	2
H 162		M91108001	トメネジ 11/64(40)X5.5.....	Screw 11/64(40)X5.5.....	1
H 163		M95051021	ロッカアナツキボルト M5X12.....	Molt M5X12.....	1
H 164		M91102045	ナット 11/64(40).....	Nut 11/64(40).....	1
H 901		MS01A3352	カラークミ.....	Collar assy.....	2

J X-Yテーブル機構
 X-Y TABLE MECHANISM

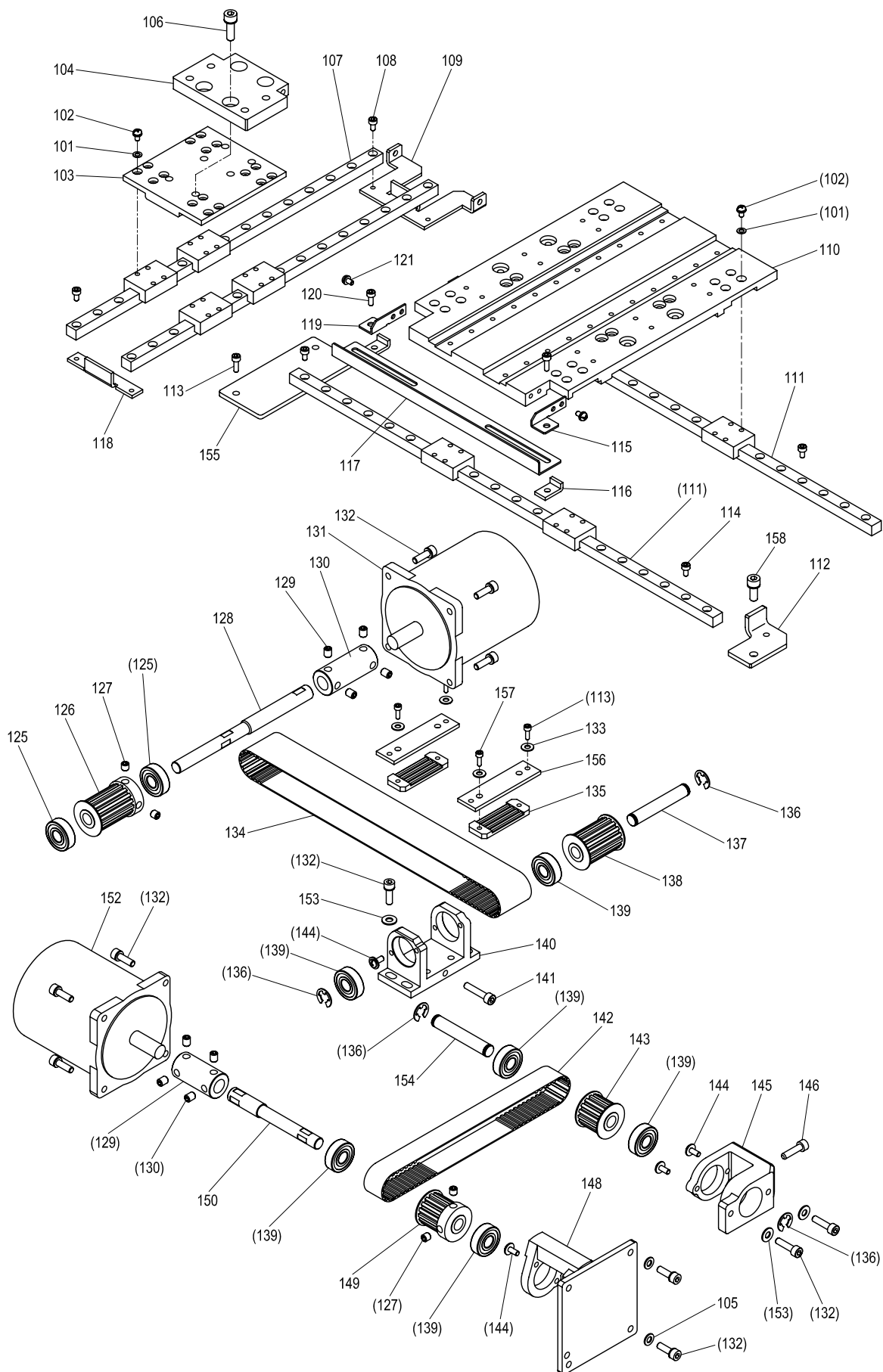

[J]X-Yテーブル機構
X-Y TABLE MECHANISM

Fig no.	変更 Mod.	部品コード Parts no.	品名	Description	数量 Amt. Req.
J 101		M90317050	ザガネ 3	Washer 3	32
J 102		M90814004	ブラマイナヘネジ M3X5.2	Screw M3X5.2	32
J 103		MB62E0957	Yシクイドウレース	Y-movable race	1
J 104		MB62E2601	オサエダイトリツケイタ	Clamp adapter	1
J 105		M90512050	ザガネ 5	Washer 5	4
J 106		M95002017	セフティソケット M5X12	Bolt M5X12	4
J 107		ME26C0920	リニアウェイ (Y)	Y-liner way	2
J 108		M93004021	ロッカアナツキホルト M3X5	Bolt M3X5	26
J 109		MB62A1477	Yシクストップ	Y-stopper	1
J 110		ME25Y0957	Xシクイドウレース	X-movable race	1
J 111		ME25Y0920	リニアウェイ (X)	X-linear way	2
J 112		ME25Y0477	Xシクストップ (R)	X-stopper (R)	2
J 113		M94001017	セフティソケット M4X10	Bolt M4X10	6
J 114		M95013021	ロッカアナツキホルト M3X10	Bolt M3X10	24
J 115		MB60A1429	ケンシュツパンスアイ (R)	Bracket (right)	1
J 116		MB60A2601	ケンシュツパントリツケイタ	Bracket	2
J 117		ME25Y0407	Xシクケンシュツパ	Detector plate X	1
J 118		MB62A4477	Yシクストップ (マ)	Y-stopper (front)	1
J 119		MB60A0429	ケンシュツパンスアイ (L)	Bracket (left)	1
J 120		M94008017	セフティソケット M4X6	Bolt M4X6	2
J 121		M90816004	SW-PWブラマイナヘネジ M3X8	Screw M3X8	4
J 125		MB62A0456	ヘアリング 6000ZZNR	Bearing	2
J 126		MB45A0767	ベルトグルマ	Cog pulley	1
J 127		M96001001	ロッカアナツキメネジ M6X8	Screw M6X8	4
J 128		MB62A1454	Xクドウシク	X-drive shaft	1
J 129		MB61A0571	ジクツギテ	Coupling	2
J 130		M96002001	ロッカアナツキメネジ M6X6	Screw M6X6	8
J 131		M95044095	ステッピングモータクミタテ (X)	Motor complete (X)	1
J 132		M95004017	セフティソケット M5X16	Bolt M5X16	18
J 133		M90422050	ザガネ 4	Washer 4	8
J 134		MB62A0523	ハダカベルト (Xシク)	Cog belt (X)	1
J 135		MA45A0778	ベルトオサエ (X)	Belt clasper (X)	2
J 136		M90604065	Eカタメリ 8	E-type retaining ring 8	4
J 137		MA21P0454	シク	Shaft	1
J 138		MB62A0767	ベルトグルマ	Cog pulley	1
J 139		MS02A2456	シールドボールヘアリング	Ball bearing	6
J 140		MA35A6758	ブラケット	Bracket	1
J 141		M95015021	ロッカアナツキホルト M5X20	Bolt M5X20	1
J 142		MB62A1523	ハダカベルト (Yシク)	Cog belt (Y)	1
J 143		MB61A0767	ベルトグルマ	Cog pulley	1
J 144		M91071004	SW-MWブラマイナヘネジ M4X8	Screw M4X8	8
J 145		ME26C0758	ブラケット	Bracket	1
J 146		M95011021	ロッカアナツキホルト M5X25	Bolt M5X25	1
J 148		ME62C1758	ブラケット	Bracket	1
J 149		MB61A2767	ベルトグルマ	Cog pulley	1
J 150		MB61A1454	Yクドウシク	Y-drive shaft	1
J 152		M95043095	ステッピングモータクミタテ (Y)	Motor complete (Y)	1
J 153		M90511050	ザガネ 5	Washer 5	6
J 154		MS02A1454	シク	Shaft	1
J 155		ME25Y1477	Xシクストップ (L)	X-stopper (L)	1
J 156		MB45A2476	スパーサ	Spacer	2
J 157		M94007017	セフティソケット M4X12	Bolt M4X12	4
J 158		M95005017	セフティソケット M5X10	Bolt M5X10	1

K 外押え機構(1)
WORK HOLDER MECHANISM(1)

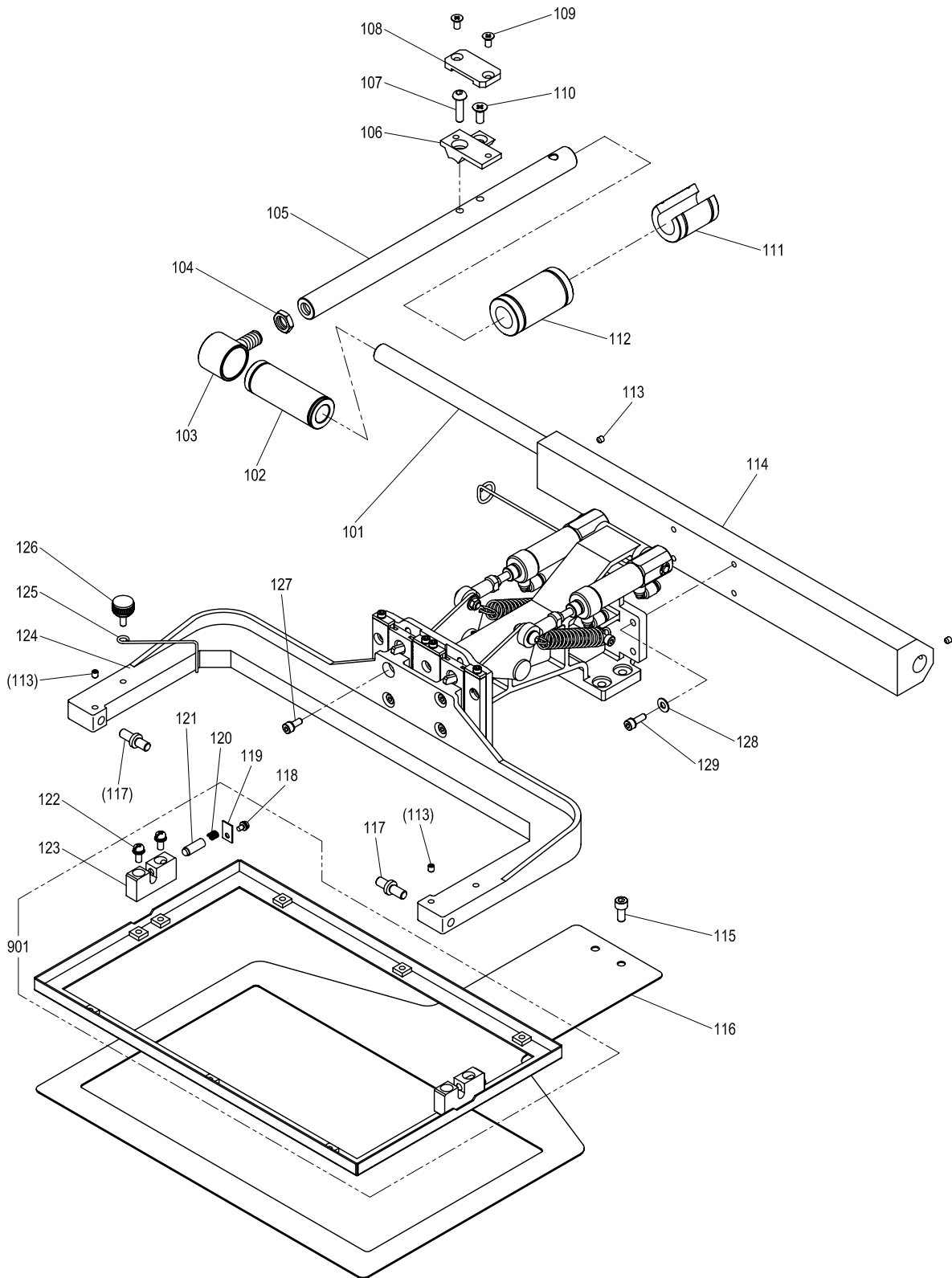

[K]外押え機構(1)
WORK HOLDER MECHANISM(1)

Fig no.	変更 Mod.	部品コード Parts no.	品名	Description	数量 Amt. Req.
K 101		ME25Y0454	ｼｸ	Shaft	1
K 102		MB62A0921	ﾘﾆｱﾌﾞｯｼﾞ	Bearing	1
K 103		ME25A0692	ｼｸｳｹﾞﾙﾊｳｼﾞﾝｸﾞ	Bearing housing	1
K 104		M92514045	ﾛｯｶｸﾅｯﾄ M10	Nut M10	1
K 105		ME26C0390	ﾕﾞﾄﾞﾗｲﾌﾞｼｸ	Y-drive shaft	1
K 106		ME25A0781	ﾕﾞﾙﾄﾞﾗｲﾌﾞ	Y-belt holder	1
K 107		M95031021	ﾛｯｶｸｱﾅｯｷﾎﾞﾙﾄ M5X12	Bolt M5X12	1
K 108		MS02A0778	ﾍﾞﾙﾄｵｻﾞｲ	Belt clasper	1
K 109		M94001037	ﾌﾟﾗｲﾈｼﾞ M4X12	Screw M4X12	2
K 110		M90505037	ﾌﾟﾗｲﾈｼﾞ M5X12	Screw M5X12	1
K 111		ME25A0921	ﾘﾆｱﾌﾞｯｼﾞ LM-16UU-OP	Bearing LM-16UU-OP	1
K 112		MB62A2921	ﾘﾆｱﾌﾞｯｼﾞ LM-16UU	Bearing LM-16UU	1
K 113		M91053020	ﾛｯｶｸｱﾅｯｷﾄﾒｼﾞ M4X6	Screw M4X6	4
K 114		ME25Y0455	ｼｸｻﾞｲ	Shaft holder	1
K 115		M99002022	8ﾄﾞﾗｲﾌﾞｼｸ ﾎﾞﾙﾄ M5X10	Bolt M5X10	2
K 116		ME25Y0272	ｵｸﾘｲﾀ	Feed plate	1
K 117		MB62A5454	ｵｻﾞｲｼﾞｸ	Clamp stud	2
K 118		M90859004	SW-PWﾌﾟﾗｲﾈｼﾞ M3X6	Screw M3X6	2
K 119		MS02B0257	ｵｻﾞｲﾀ	Holder plate	2
K 120		MS13A0572	ﾁﾙﾏｷﾊﾞﾈ	Coil spring	2
K 121		M90611060	ﾋﾞﾝ	Pin	2
K 122		M91056004	SW-PWﾌﾟﾗｲﾈｼﾞ M4X10	Screw M4X10	4
K 123		ME40A0426	ｻﾞｲ	Support	2
K 124		ME25Y0273	ｵｻﾞｲﾀ	Clamp adapter	1
K 125		MB61A2477	ｽﾄｯﾊﾟ	Stopper	1
K 126		MA20A0650	ﾅｰﾙﾄﾞﾉﾌﾞ	Knurled knob	1
K 127		M95005017	ｾﾌﾞﾃﾞｯｼﾞ M5X10	Bolt M5X10	4
K 128		M90421050	ｻﾞﾞｶﾞﾈ 4	Washer 4	4
K 129		M94006017	ｾﾌﾞﾃﾞｯｼﾞ M4X16	Bolt M4X16	4
K 901		ME25Y0105	ｼﾞｸ ﾎﾞﾙﾄ	Clamp frame assy	1

L 外押え機構(2)
 WORK HOLDER MECHANISM(2)

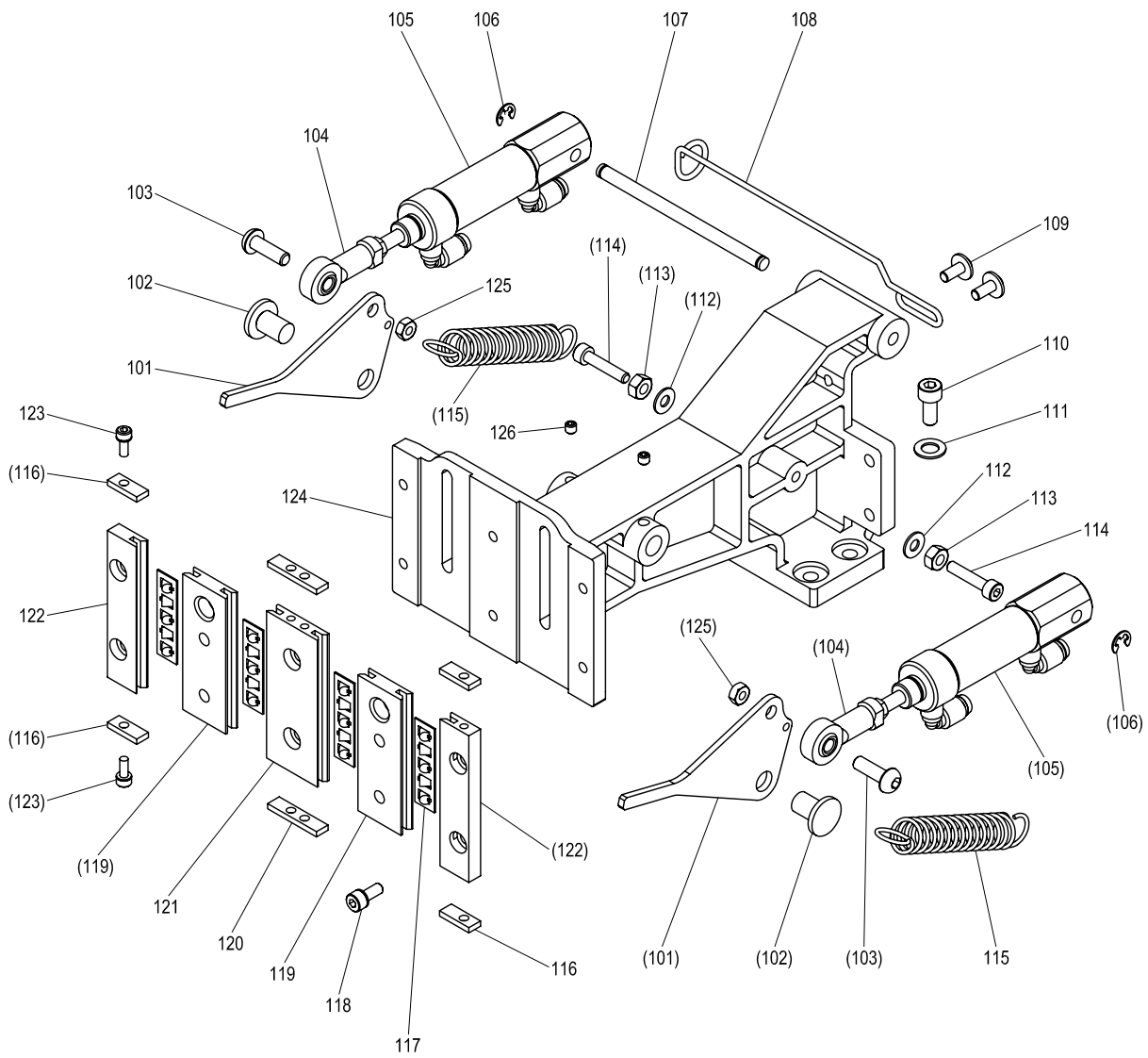

[L]外押え機構(2)

WORK HOLDER MECHANISM(2)

Fig no.	変更 Mod.	部品コード Parts no.	品名	Description	数量 Amt. Req.
L 101		MB62A0950	オサエレバ	Pushing lever	2
L 102		MB61A3454	ツバツキシク	Shaft	2
L 103		M95037021	ロツカクアナツキボルト M5X16	Bolt M5X16	2
L 104		MB62A0975	ロツドエント	Connecting link	2
L 105		MB62A1434	エアシリンダ (ワツタツツキテツキ)	Air cylinder (with quick joint)	2
L 106		M90504065	Eガタメツ 4	E-type retaining ring 5	2
L 107		M90532060	ピン	Pin	1
L 108		MB62A0707	ハンガ	Hanger	1
L 109		M91013004	SW-MWフライナハネシ M4X10	Screw M4X10	2
L 110		M95001017	セフテツソケット M5X20	Bolt M5X20	4
L 111		M90511050	ザガネ 5	Washer 5	4
L 112		M90421050	ザガネ 4	Washer 4	2
L 113		M91007075	ナツ M4	Nut M4	2
L 114		M94015021	ロツカクアナツキボルト M4X20	Screw M4X20	2
L 115		MB62A0572	ツルマキハネ	Spring	2
L 116		MB61A1477	ストップ	Stopper	4
L 117		M94008070	ローラリテーナ	Slide bearing	4
L 118		M94001017	セフテツソケット M4X10	Bolt M4X10	6
L 119		MB62A1957	イドウレース	Movable race	2
L 120		MA22A0477	ストップ	Stopper	2
L 121		MA22A2957	コテイレース	Fixed race	1
L 122		MB62A0957	コテイレース	Fixed race	2
L 123		M94012017	セフテツソケット M3X8	Bolt M3X8	8
L 124		MB62A0263	オサエダイ	Clamp bracket	1
L 125		M91382045	ナツ M5	Nut M5	2
L 126		M91055020	ロツカクアナツキメネジ M4X4	Screw M4X4	2

M ワイパー機構
WIPER MECHANISM

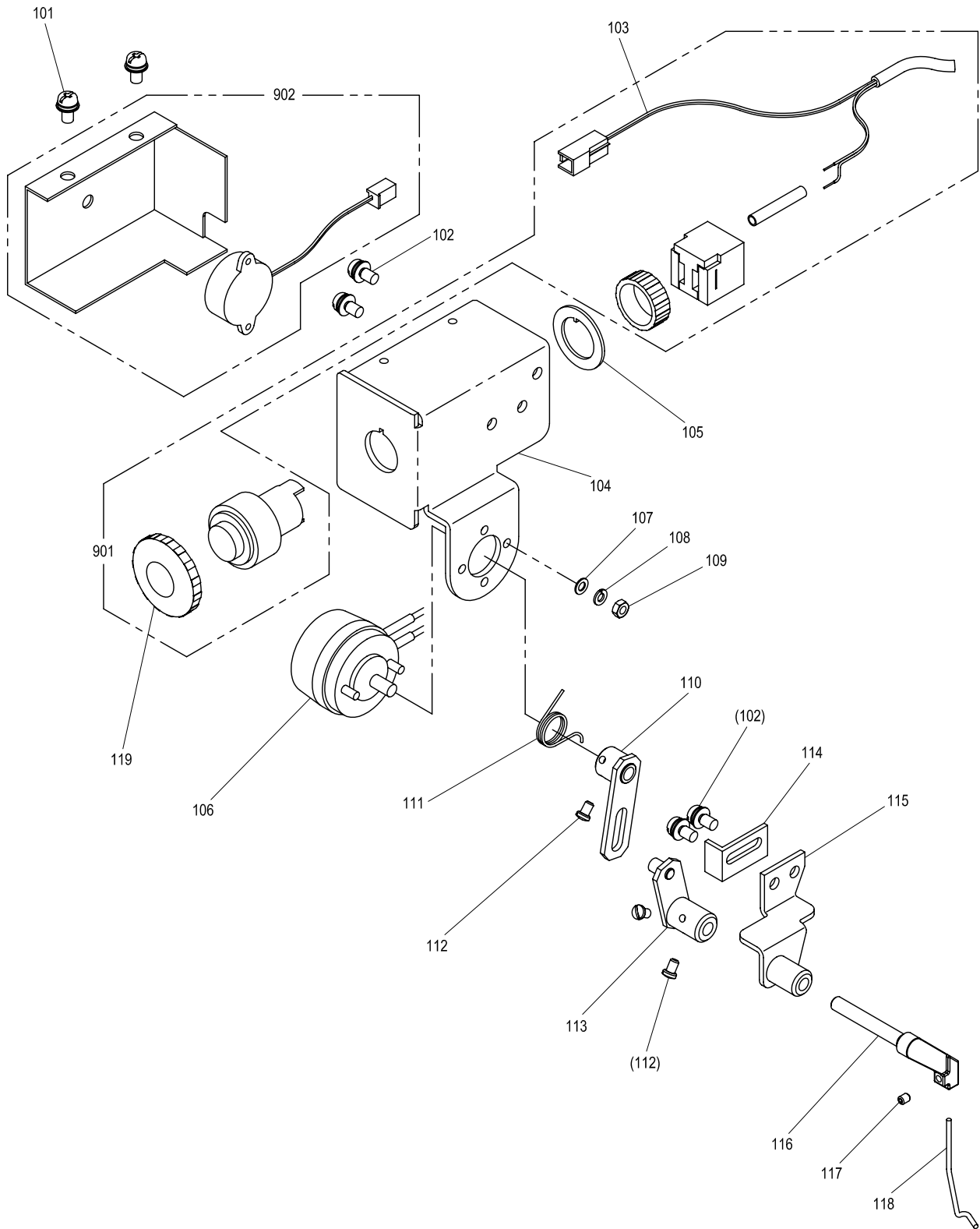

[M]ワイパー機構
WIPER MECHANISM

Fig no.	変更 Mod.	部品コード Parts no.	品名	Description	数量 Amt. Req.
M 101		M91054004	SW-PWブライナヘネジ M4X8	Screw M4X8	2
M 102		M91056004	SW-PWブライナヘネジ M4X10	Screw M4X10	4
M 103		M97356099	セツクテフセン	Cable (stop BZ)	1
M 104		ME10E3601	トリツケイタ	Bracket	1
M 105		MB60A0915	ロックリング	Lock ring	1
M 106		MB61E1519	ワイパーソレノイド	Solenoid (wiper)	1
M 107		M90317050	ザガネ 3	Washer 3	2
M 108		M90307053	ハネザガネ 3	Spring washer 3	2
M 109		M90875045	ナット M3	Nut M3	2
M 110		MS02E0983	クドウイタ	Wiper crank	1
M 111		MS02A4729	ヒネリバネ	Spring	1
M 112		M90802003	マルヒラネジ 1/8(44)X4.5	Screw 1/8(44)x4.5	4
M 113		MB61A0436	シュウドウイタ	Wiper crank	1
M 114		MS02A1477	ストップバ	Stopper	1
M 115		MS10A0982	ワイパータイ	Wipper adapter	1
M 116		MB61E0982	ワイパーシャフト	Wiper shaft	1
M 117		M91057020	ロックアナツキメネジ M3X4	Screw M3X4	1
M 118		MA20A0980	ワイパー	Wiper	1
M 119		ME03A0270	プッシュボタン	Push button	1
M 901		ME10E0270	オンボタンスイッチクミ	Switch assy	1
M 902		MB60E3339	カバークミ (ブザーつき)	Cover assy (with buzzer)	1

N 給油機構
OIL LUBRICATION MECHANISM

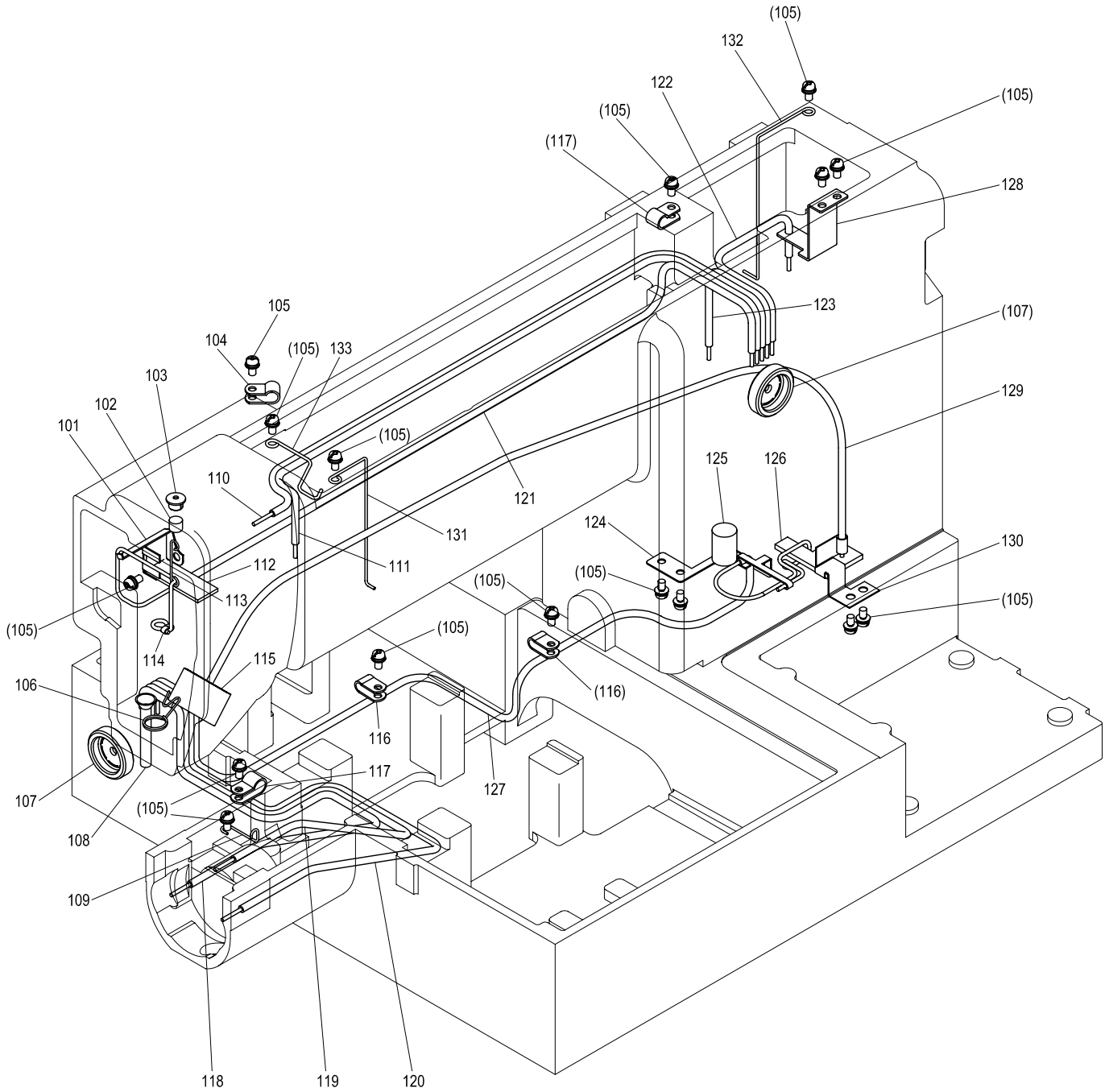

[N] 給油機構

OIL LUBRICATION MECHANISM

Fig no.	変更 Mod.	部品コード Parts no.	品名	Description	数量 Amt. Req.
N 101		ME10A1780	ホルダ	Holder	1
N 102		MF10A2740	フェルト	Felt	1
N 103		MF60A0742	フタ	Cap	1
N 104		MS14A1620	ナイロンクリップ AB-4N	Nylon clip AB-4N	1
N 105		M91054004	SW-PWブラマイナベネジ M4X8	Screw M4X8	16
N 106		MF00A2780	ホルダ	Holder	1
N 107		MN10A0135	オイルゲージ	Oil gauge	2
N 109		MS01A8796	ホルダ	Holder	1
N 110		MB62E3148	パイプヒモカミ (ウワシクメタル マI)	Oil pipe assy (drive shaft bushing F)	1
N 111		MB60E2148	パイプヒモカミ (ハンシンリン)	Oil pipe assy (eccentric cam)	1
N 112		MS01A1740	フェルト	Felt	1
N 113		MS03A2780	ホルダ	Holder	1
N 114		MF80A0780	ホルダ	Holder	1
N 115		MS08A0740	フェルト	Felt	1
N 116		M94003099	ナイロンクリップ AB-3N	Nylon clip AB-3N	2
N 117		MN60A0620	ナイロンクリップ AB-5N	Nylon clip AB-5N	2
N 118		ME25E0688	パイプヒモカミ (カマ ヒダリ)	Oil pipe assy (hook left)	1
N 119		MB62E4148	パイプヒモカミ (カマ ナカ)	Oil pipe assy (hook center)	1
N 120		ME25E1688	パイプヒモカミ (カマ ミギ)	Oil pipe assy (hook right)	1
N 121		MB62E1148	パイプヒモカミ (ハリホウ)	Oil pipe assy (needle bar)	1
N 122		ME03E5688	パイプヒモカミ (レンセツカン)	Oil pipe assy (connecting rod)	1
N 123		MA20E3688	パイプヒモカミ (ウワシクメタル ナカ)	Oil pipe assy (drive shaft bushing C)	1
N 124		MS14A3780	ホルダ	Holder	1
N 125		MF60A5740	フェルト	Felt	1
N 126		MS14A0740	フェルト	Felt	1
N 127		ME25E3688	パイプヒモカミ (シタシクメタル ウシロ)	Oil pipe assy (hook shaft bushing R)	1
N 128		MB60A1780	ホルダ	Holder	1
N 129		MB62E0148	パイプヒモカミ (カンユ)	Oil pipe assy (circulation)	1
N 130		MS01A9796	ホルダ	Holder	1
N 131		MS10A0780	ホルダ	Holder	1
N 132		ME20A1780	ホルダ	Holder	1
N 133		MA20A1780	ホルダ	Holder	1

P 配線配管関係
CABLE COMPONENT & PNEUMATIC CONTROL UNIT

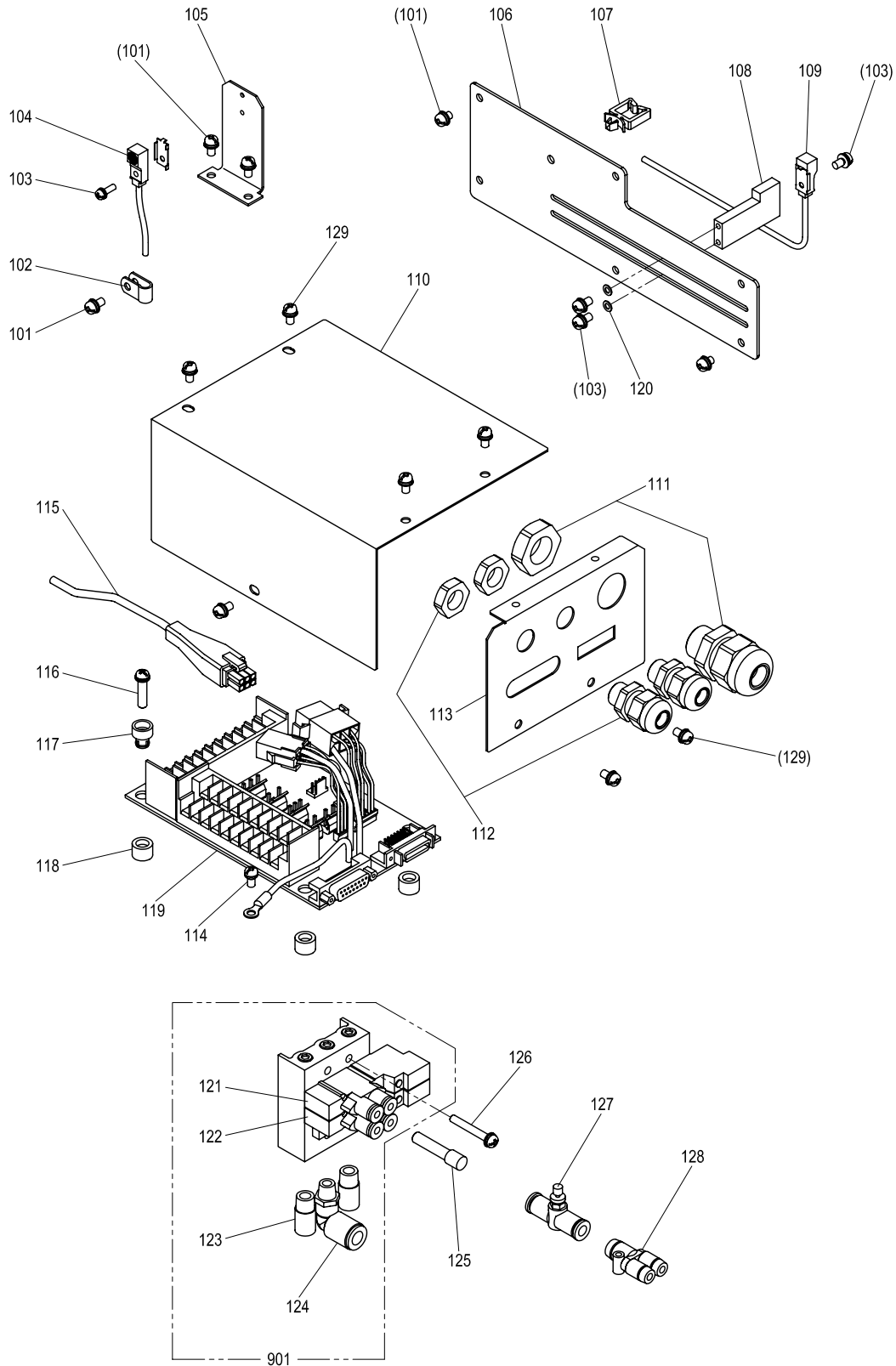

[P]配線・配管関係

CABLE COMPONENT & PNEUMATIC CONTROL UNIT

Fig no.	変更 Mod.	部品コード Parts no.	品名	Description	数量 Amt. Req.
P 101		M91054004	SW-PWブラマイナヘネジ M4X8	Screw M4X8	12
P 102		M94003099	ナイロンクリップ AB-3N	Nylon clip AB-3N	4
P 103		M90971004	SW-PWブラマイナヘネジ M3X10	Screw M3X10	4
P 104		ME26C0484	キンセツスイッチ X	Detector X	1
P 105		ME25Y0408	ケンシュツダイ X	Detector bracket X	1
P 106		ME25A2339	カバー	Cover	1
P 107		ME25A0389	ケーブルクランプ	Cable clamp	1
P 108		ME25A0408	ケンシュツダイ Y	Detector bracket Y	1
P 109		ME25A0484	キンセツスイッチ Y	Detector Y	1
P 110		MB60A5339	パネルカバー	Circuit board cover	1
P 111		MB60A5780	コードブッシュ 大	Cord bushing (large)	1
P 112		MB60A6780	コードブッシュ 小	Cord bushing (small)	2
P 113		MB60A5601	コネクタリツケイタ	Connector panel	1
P 114		M90439037	SWブラマイナヘネジ M4X8	Screw M4X8	1
P 115		K14M71725402	ケーブル (エンコーダ)	Cable (encoder)	1
P 116		M91057004	SW-PWブラマイナヘネジ M4X20	Screw M4X20	4
P 117		MB60A0366	ワシヤブッシュ	Nylon bush	4
P 118		MB60A2352	ワシヤブッシュ	Nylon bush	4
P 119	A	M800E2CON	プリント基板	Print circuit board	1
P 120		M90316050	ワシヤ 3	Washer 3	2
P 121		MB62A1599	ソレノイドバルブ (ナカオサエ)	Solenoid valve (presser bar lifting)	1
P 122		MB62A2599	ソレノイドバルブ (ソトオサエ)	Solenoid valve (work holder)	1
P 123		M91035089	サイレンサ AN101-01	Muffler	2
P 124		MA20A8571	L型クイックジョイント KQL08-01S	L-type quick joint	1
P 125		MB62A0757	プラグ	Plug	1
P 126		M91276004	SW-PWブラマイナヘネジ M4X30	Screw M4X30	4
P 127		MA16A0495	スピードコントローラ AS1001-F06	Speed controller	1
P 128		MA20A6571	Y型クイックジョイント Y KJU04-06	Y-type quick joint	1
P 129		M91071004	SW-PWブラマイナヘネジ M4X8	Screw M4X8	7
P 901		MB62E0599	ソレノイドバルブ組立	Solenoid valve assy	1

Q テーブル関係
TABLE & STAND

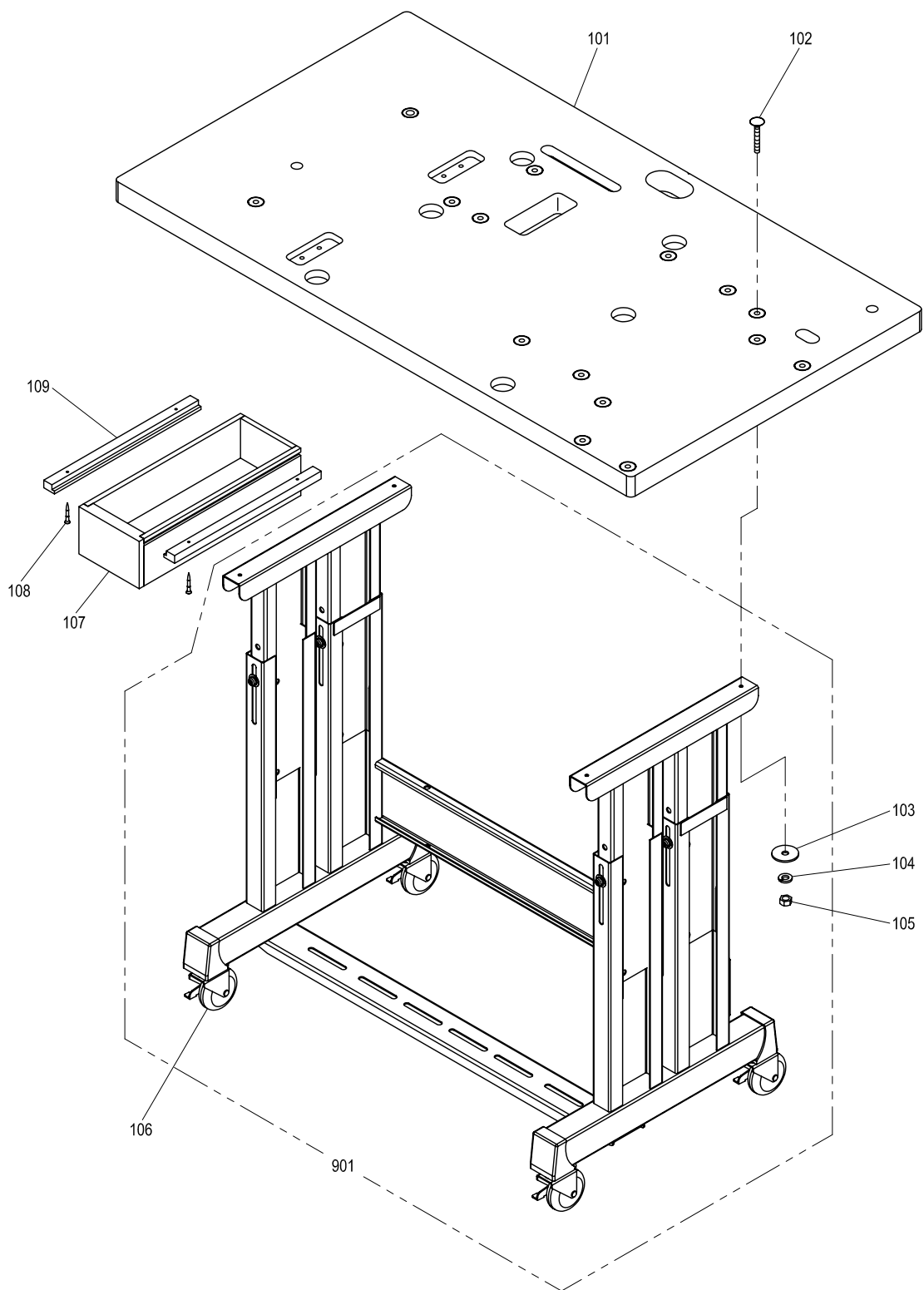

[Q]テーブル関係
TABLE & STAND

Fig no.	変更 Mod.	部品コード Parts no.	品 名	Description	数量 Amt. Req.
Q 101		ME25Y0595	テシイタ	Table top	1
Q 102		K14M90451403	トリツケボルト M8X70	Mounting bolt M8X70	4
Q 103		M90710050	トクシユザガネ 8	Special washer 8	4
Q 104		M90802053	ハネザガネ 8	Spring washer 8	4
Q 105		M92008045	ナツト M8	Nut M8	4
Q 106		MB60A1368	キャスト	Caster	4
Q 107		MB60A0719	ヒキダシ	Drawer	1
Q 108		M90406040	Pサラモクネジ 4.5X38	Wooden screw 4.5X38	4
Q 109		MB60A3957	レール	Rail	2
Q 901		MB60E0150	キャククミタテ	Leg assy	1

R 付属品(1)
ACCESSORIES(1)

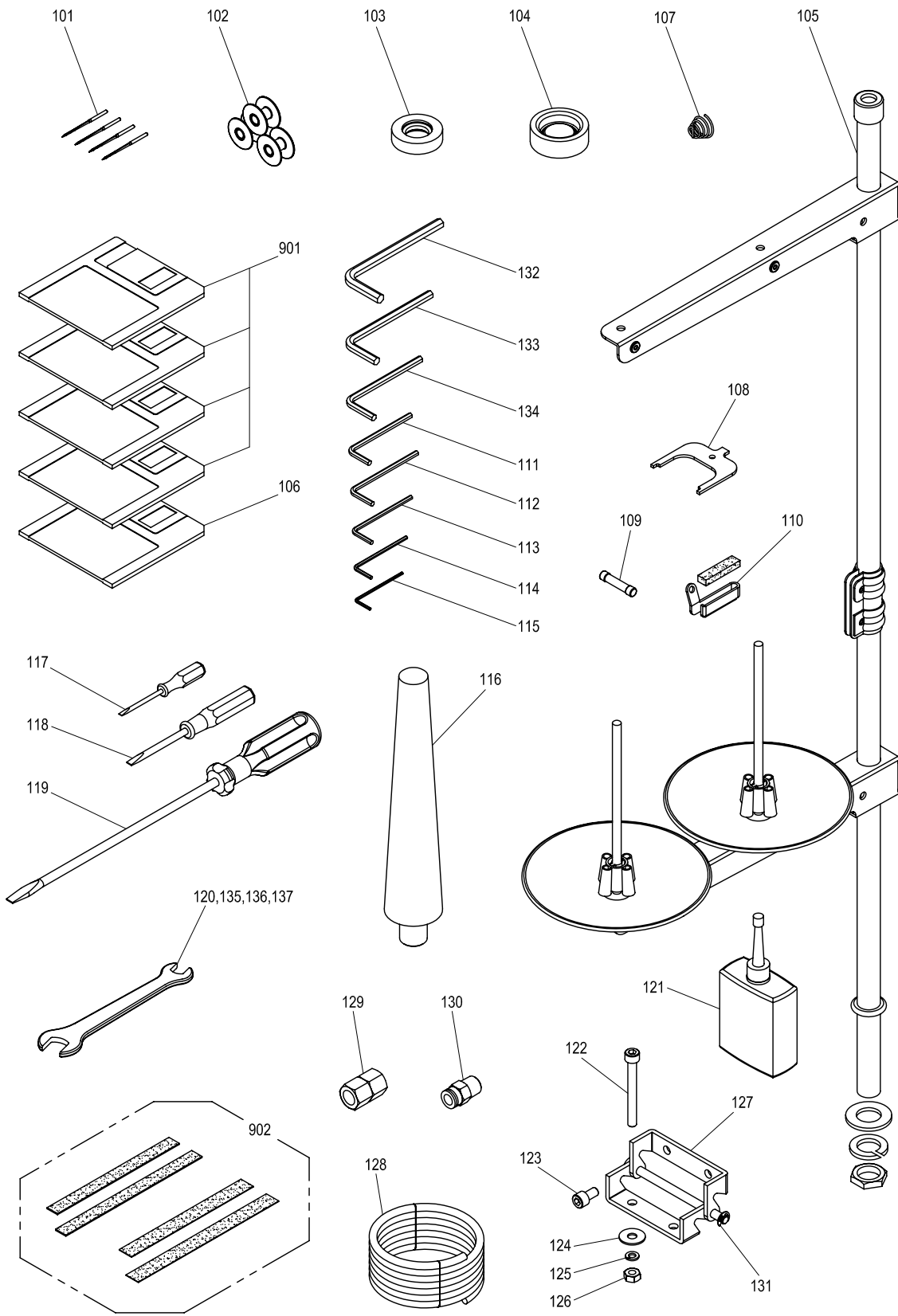

[R] 付属品(1)
ACCESSORIES(1)

Fig no.	変更 Mod.	部品コード Parts no.	品名	Description	数量 Amt. Req.
R 101		MS02A0128	ミシンハリ DPX17#18	Needle DPX17#18	4
R 102		MA10A0123	ホビン	Bobbin	3
R 103		MS03A0417	ゴムワ (イトマキヨウ)	Tire (for bobbin winder)	1
R 104		MB60A0419	ホウシンゴム	Rubber cushion	6
R 105		MF40E0193	イトタテダ イクミタテ	Cotton stand assy	1
R 106		MB60A1990	データロッドディスク	Pattern data F/D	1
R 107		MN52A1245	エンスバネ	Tension spring	1
R 108		MF01A0565	カドチョウセイク	Speed command disk adjusting plate	1
R 109		M82510FUS	ヒューズ	Fuse	2
R 110		MS03A0181	イトアンナイ	Thread guide	1
R 111		MS01A1976	ロッカホウレンチ 4	Hexagonal wrench 4	1
R 112		MS02A2976	ロッカホウレンチ 3	Hexagonal wrench 3	1
R 113		MS02A1976	ロッカホウレンチ 2.5	Hexagonal wrench 2.5	1
R 114		MS02A0976	ロッカホウレンチ 2	Hexagonal wrench 2	1
R 115		MS10A0976	ロッカホウレンチ 1.5	Hexagonal wrench 1.5	1
R 116		MA20A0613	トウブササエ	Head rest	1
R 117		MB02A1608	ドライバ (ショウ)	Screw driver (small)	1
R 118		MB02A0608	ドライバ (チュウ)	Screw driver (middle)	1
R 119		MF00A0608	ドライバ (ダイ)	Screw driver (large)	1
R 120		MM10A1479	スパナ 10-14	Spanner 10-14	1
R 121		MF10A0149	アブラサシ	Oiler with oil	1
R 122		M96020021	ロッカアナツキボルト M6X55	Bolt M6x55	4
R 123		M96002017	セフティソケット M6X12	Bolt M6x12	4
R 124		M90630050	ワシガネ 6.5-18	Washer 6.5-18	4
R 125		M90624053	バネザガネ 6	Spring washer 6	4
R 126		M91576045	ナット M6	Nut M6	4
R 127		MB60A0560	チョウハン	Hinge	2
R 128		MS06A0567	エアチューブ	Air tube	1
R 129		M91010089	ロッカソケット YST-2ガタ NP-202	Socket	1
R 130		MA30A0571	ワンタッチツギテ KQH08-02S	Quick joint	1
R 131		M90809065	Eガタメリ 5	E-type retaining ring 5	1
R 132		MS05A1976	ロッカホウレンチ 6	Hexagonal wrench 6	1
R 133		MS05A0976	ロッカホウレンチ 5	Hexagonal wrench 5	1
R 134		MF90A0976	ロッカホウレンチ 1/8"	Hexagonal wrench 1/8"	1
R 135		MS02A0479	スパナ 13-17	Spanner 13-17	1
R 136		MS10A1976	スパナ 8-9	Spanner 8-9	1
R 137		MS10A2976	スパナ 6-7	Spanner 6-7	1
R 901		ME20E0990	システムF/Dロッドディスク (4マイ)	System F/D (4discs)	1
R 902		ME25Y0691	バッキンセット	Clamp pad set	1

S 付属品(2)
ACCESSORIES(2)

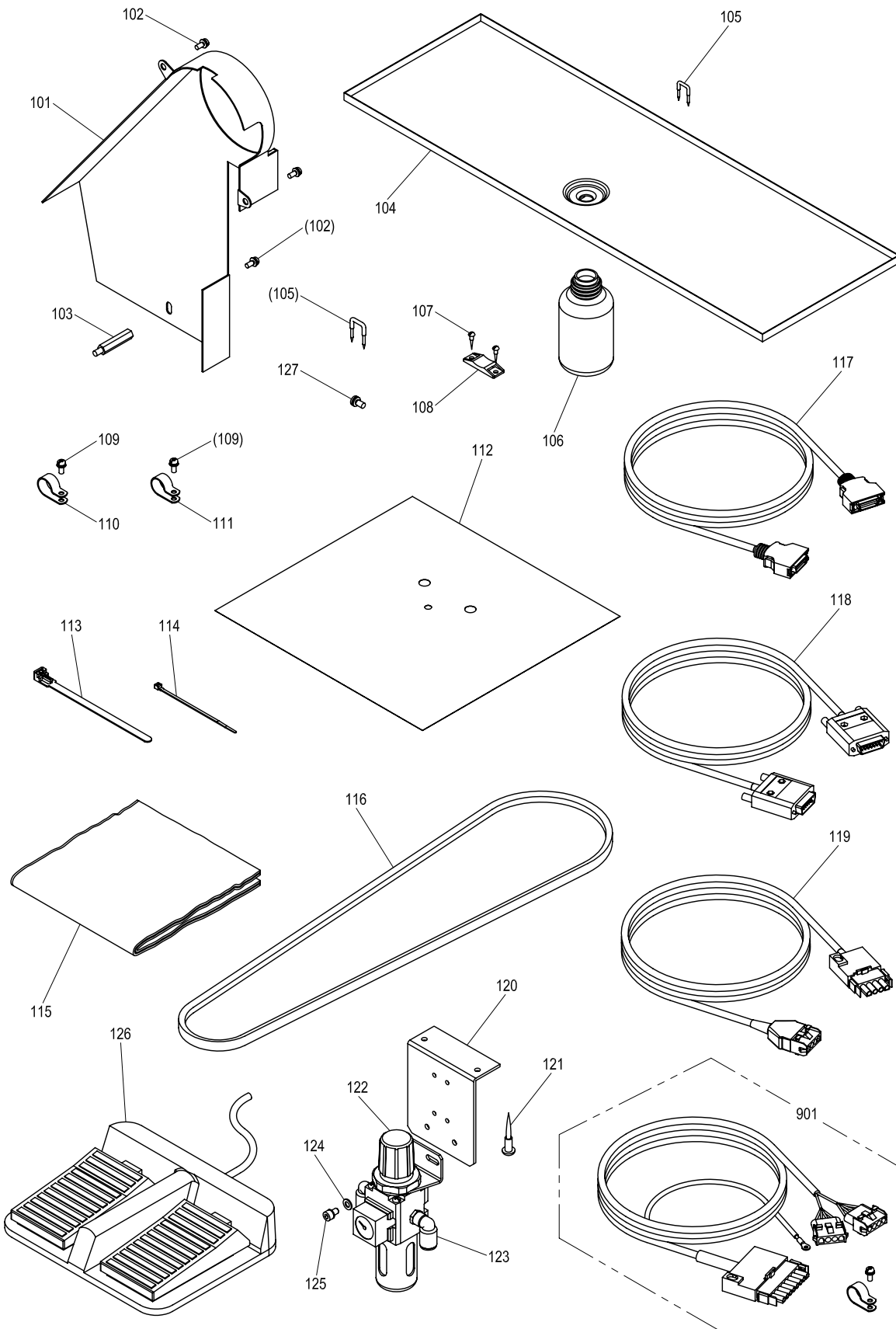

[S] 付属品(2)
ACCESSORIES(2)

Fig no.	変更 Mod.	部品コード Parts no.	品名	Description	数量 Amt. Req.
S 101		MB62E0776	ベルトカバー	Belt cover	1
S 102		M91067004	SW-PWブラマイネジ M5X10	Screw M5X10	3
S 103		M95001031	トクシボルト M5	Special bolt M5	1
S 104		MB62E0131	アブラウケ	Oil pan	1
S 105		M90001043	ステッフル	Staple	7
S 106		MF20A0130	アブラビン	Oil bottle	1
S 107		M90306041	マルモクネジ 3.1X16	Wood screw 3.1x16	4
S 108		MB60A0420	コタイグ	Tie holder	2
S 109		M91056004	SW-PWブラマイネジ M4X10	Screw M4X10	2
S 110		MB60A2620	ナイロンクリップ AB-10N	Nylon clip AB-10N	1
S 111		MB60A1620	ナイロンクリップ AB-8N	Nylon clip AB-8N	1
S 112		ME25Y0797	ホコフィルム	Film sheet	1
S 113		MB60A0201	ハインダー	Cord tie	2
S 114		MG51A0201	ハインダー	Cord tie	1
S 115		MA20A0734	ビニルカバー	Polyethylene cover	1
S 116		MB62A0777	Vベルト M46	V-belt M46	1
S 117		M97319099	ケーブル (ニューリヨクシンゴウ)	Cable (input signal)	1
S 118		M97320099	ケーブル (ソレノイド)	Cable (solenoid)	1
S 119		M97318099	ケーブル (サーボモータ)	Cable (servo motor)	1
S 120		MB61A5601	レギュレ-タリツケイタ	Filter regulator adapter	1
S 121		M90409041	マルモクネジ 4.5X20	Screw 4.5X20	2
S 122		ME40A0963	フィルタレギュレ-タ (ステーヅキ)	Filter regulator	1
S 123		MA20A8571	Lカタツキテ KQL08-01S	L-type quick joint	2
S 124		M90511050	ワッシャ 5	Washer 5	2
S 125		M95003017	セフティソケット M5X8	Bolt M5X8	2
S 126		M860A0FSW	フットスイッチ	Foot switch	1
S 127		M90439037	SWブラマイネジ M4X8	Screw M4X8	1
S 901		M97321099	ケーブル (パルスモータ)	Cable (pulse motor)	1

T オプションパーツ
OPTION PARTS

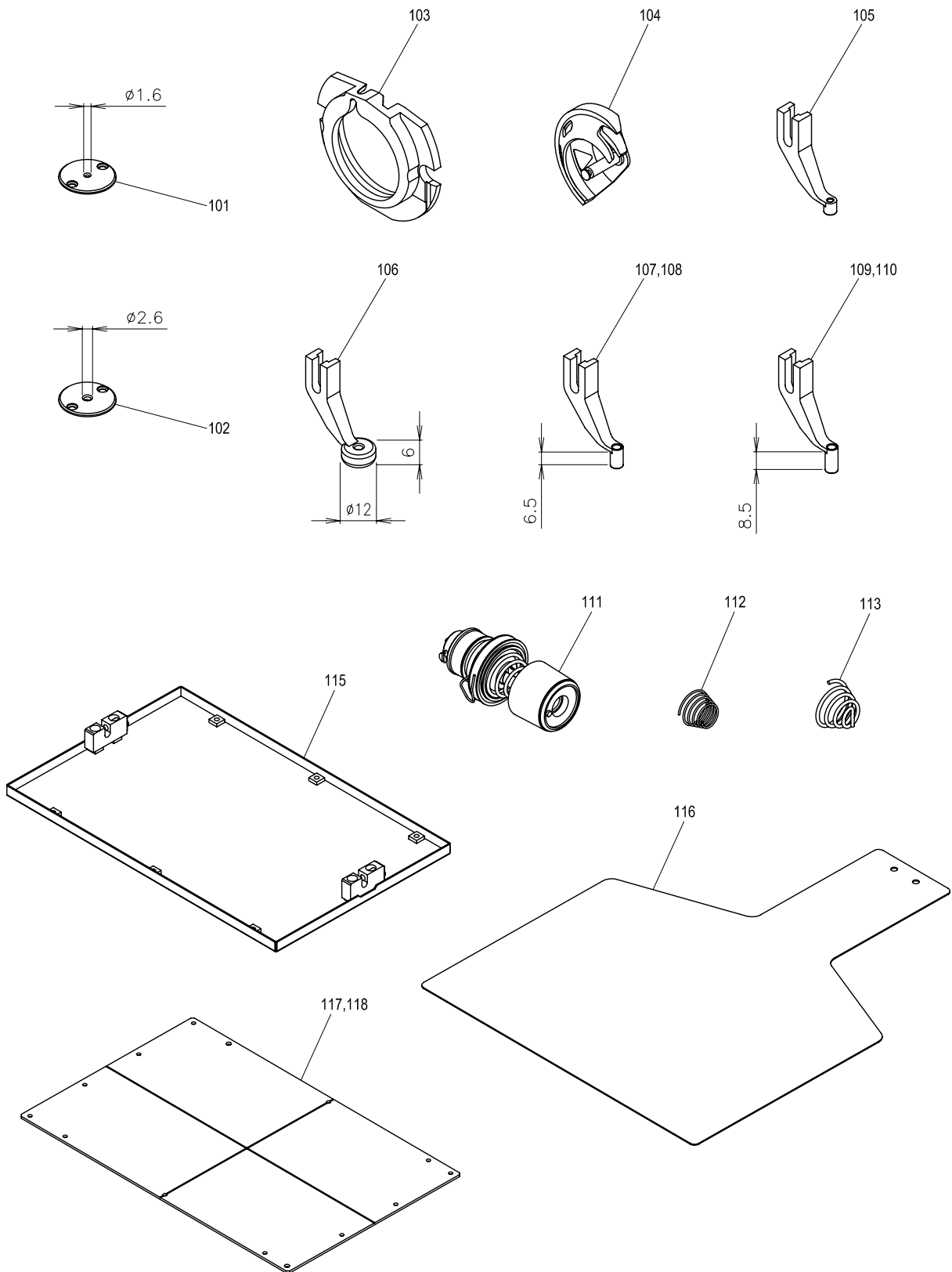

[T]オプションパーツ
OPTION PARTS

Fig no.	変更 Mod.	部品コード Parts no.	品名	Description	数量 Amt. Req.
T 101		MS03A0101	ハリイタ (ウスモ/ヨウ) 1.6	Needle plate (for light) 1.6	1
T 102		MS03A2101	ハリイタ (アツモ/ヨウ) 2.6	Needle plate (for heavy) 2.6	1
T 103		MS01A1616	ナカガマオサエ (アツモ/ヨウ)	Inner hook clamper (for heavy)	1
T 104		MS17A1120	ナカガマ (アツモ/ヨウ)	Inner hook (for heavy)	1
T 105		MV30A1256	ナカオサエ (ウスモ/ヨウ)	Presser foot (for light)	1
T 106		MV35A0106	サラオサエ 3	Presser foot 3	1
T 107		MS03A0256	ナカオサエ 3	Presser foot 3	1
T 108		MS03A1256	ナカオサエ 2	Presser foot 2	1
T 109		MA35A0256	ナカオサエ 3	Presser foot 3	1
T 110		MA35A1256	ナカオサエ 2	Presser foot 2	1
T 111		MS04E1210	ウワイトチョウセツキ (ウミ)	Thread tension regulator assy	1
T 112		MF10A1245	エンスイバネ (プリテンションヨウ)	Spring (for pretension)	1
T 113		MN10A3245	エンスイバネ (ウワイトチョウセツキヨウ)	Spring (for thread tension regulator)	1
T 115		MB62E3105	ソトオサエクミタテ (アナナシ)	Clamp frame assy (blank)	1
T 116		MB62A0272	シタオサエイタ (アナナシ)	Feed plate (blank)	1
T 117		MB62A0762	ナカオサエイタ (2T,ケガキセンアリ)	Clamp plate (with line)	1
T 118		MB62A1762	ナカオサエイタ (2T,ケガキセンナシ)	Clamp plate	1

索引
INDEX-1

部品コード Parts No.	ページ Page	Fig No.	部品コード Parts No.	ページ Page	Fig No.	部品コード Parts No.	ページ Page	Fig No.	部品コード Parts No.	ページ Page	Fig No.
K14M71725402	... P27	... P 115	M90806002	... P3	... B 129	M91058004	... P7	... D 101	M93004021	... P17	... J 108
K14M90451403	... P29	... Q 102	M90809065	... P31	... R 131	M91058020	... P13	... G 113	M93202047	... P13	... G 131
M800E1CON	... P27	... P 119	M90814004	... P17	... J 102	M91059004	... P9	... E 103	M93220035	... P13	... G 130
M82510FUS	... P31	... R 109	M90815002	... P9	... E 130	M91066004	... P3	... B 136	M94001017	... P3	... B 121
M860A0FSW	... P33	... S 126	M90816004	... P17	... J 121	M91067004	... P33	... S 102		... P17	... J 113
M90001043	... P33	... S 105	M90823050	... P3	... B 109	M91071004	... P3	... B 138		... P21	... L 118
M90001060	... P11	... F 128	M90825002	... P15	... H 102		... P17	... J 144	M94001037	... P19	... K 109
M90101017	... P15	... H 152	M90853002	... P11	... F 126		... P27	... P 129	M94003099	... P25	... N 116
M90204060	... P5	... C 163	M90859004	... P3	... B 123	M91101017	... P15	... H 138		... P27	... P 102
M90306041	... P33	... S 107		... P7	... D 104	M91101046	... P5	... C 149	M94006017	... P19	... K 129
M90307053	... P23	... M 108		... P19	... K 118	M91102045	... P15	... H 164	M94007017	... P17	... J 157
M90316050	... P27	... P 120	M90875045	... P23	... M 109	M91104045	... P15	... H 150	M94008017	... P17	... J 120
M90317050	... P17	... J 101	M90883080	... P3	... B 137	M91108001	... P15	... H 162	M94008070	... P21	... L 117
	... P23	... M 107	M90901002	... P5	... C 162	M91109045	... P15	... H 158	M94012017	... P21	... L 123
M90323050	... P11	... F 130	M90906003	... P3	... B 120	M91110002	... P3	... B 127	M94015021	... P21	... L 114
M90325065	... P13	... G 128		... P15	... H 127	M91112002	... P15	... H 106	M95001017	... P21	... L 110
M90330065	... P9	... E 105	M90909003	... P3	... B 125	M91119002	... P9	... E 142	M95001021	... P11	... F 123
M90359037	... P7	... D 108		... P13	... G 115	M91127015	... P15	... H 101	M95001031	... P33	... S 103
M90406040	... P29	... Q 108	M90920002	... P5	... C 108	M91129015	... P15	... H 130	M95002001	... P11	... F 104
M90406064	... P9	... E 140	M90922002	... P13	... G 139	M91131002	... P13	... G 146	M95002017	... P3	... B 118
M90409041	... P33	... S 121	M90939002	... P5	... C 109	M91182080	... P3	... B 135		... P15	... H 161
M90421050	... P3	... B 139	M90971004	... P27	... P 103	M91203002	... P11	... F 101		... P17	... J 106
	... P9	... E 102	M90990002	... P3	... B 114	M91214015	... P15	... H 133	M95003001	... P9	... E 122
	... P19	... K 128		... P7	... D 113	M91219015	... P13	... G 147		... P9	... E 144
	... P21	... L 112		... P9	... E 136	M91224001	... P15	... H 131		... P11	... F 133
M90422050	... P15	... H 109		... P15	... H 119	M91276004	... P5	... C 102	M95003017	... P13	... G 150
	... P17	... J 133	M91004067	... P5	... C 120		... P27	... P 126		... P33	... S 125
M90423060	... P13	... G 145	M91005067	... P5	... C 122	M91382045	... P15	... H 112	M95003021	... P15	... H 141
M90424053	... P15	... H 108	M91007045	... P15	... H 107		... P21	... L 125	M95004017	... P17	... J 132
M90439037	... P27	... P 114	M91007075	... P21	... L 113	M91503001	... P11	... F 111	M95004020	... P5	... C 160
	... P33	... S 127	M91010089	... P31	... R 129	M91504031	... P13	... G 144		... P13	... G 156
M90500085	... P11	... F 115	M91011004	... P5	... C 144	M91506001	... P13	... G 136	M95004021	... P11	... F 107
M90504065	... P21	... L 106	M91013004	... P5	... C 103	M91520002	... P9	... E 112		... P15	... H 151
M90505037	... P19	... K 110		... P21	... L 109	M91551015	... P13	... G 125	M95005017	... P15	... H 111
M90511050	... P3	... B 117	M91035089	... P27	... P 123	M91572045	... P13	... G 122		... P17	... J 158
	... P15	... H 160	M91053020	... P5	... C 142	M91576045	... P15	... H 145		... P19	... K 127
	... P17	... J 153		... P9	... E 120		... P31	... R 126	M95006017	... P13	... G 154
	... P21	... L 111		... P19	... K 113	M91602001	... P9	... E 118	M95006020	... P9	... E 143
	... P33	... S 124	M91054004	... P3	... B 103	M91602046	... P5	... C 117	M95011021	... P17	... J 146
M90512050	... P17	... J 105		... P5	... C 140	M91603003	... P13	... G 121	M95013021	... P17	... J 114
M90513065	... P15	... H 136		... P15	... H 118	M91606001	... P9	... E 133	M95015021	... P17	... J 141
M90532060	... P21	... L 107		... P23	... M 101		... P13	... G 129	M95031021	... P19	... K 107
M90601064	... P5	... C 123		... P25	... N 105	M91610046	... P5	... C 155	M95037021	... P21	... L 103
M90604065	... P17	... J 136		... P27	... P 101	M91652020	... P15	... H 146	M95043095	... P17	... J 152
M90605010	... P15	... H 122	M91055020	... P5	... C 119	M91688015	... P13	... G 109	M95044095	... P17	... J 131
M90611060	... P19	... K 121		... P21	... L 126	M91689015	... P13	... G 107	M95051021	... P15	... H 163
M90624053	... P31	... R 125	M91056004	... P13	... G 104	M91801035	... P13	... G 101	M96001001	... P17	... J 127
M90630050	... P31	... R 124		... P15	... H 142	M91802006	... P9	... E 132	M96002001	... P17	... J 130
M90631050	... P3	... B 112		... P19	... K 122	M91802045	... P11	... F 105	M96002017	... P3	... B 113
	... P13	... G 123		... P23	... M 102		... P13	... G 102		... P31	... R 123
M90632050	... P13	... G 133		... P33	... S 109	M91803022	... P3	... B 108	M96002020	... P11	... F 114
M90710050	... P29	... Q 103	M91057004	... P3	... B 128	M91910080	... P3	... B 105	M96004052	... P15	... H 129
M90802003	... P11	... F 129		... P27	... P 116	M92008045	... P29	... Q 105	M96020021	... P31	... R 122
	... P23	... M 112	M91057020	... P5	... C 128	M92514045	... P19	... K 104	M97318099	... P33	... S 119
M90802053	... P29	... Q 104		... P23	... M 117	M93001050	... P9	... E 106	M97319099	... P33	... S 117

索引
INDEX-2

部品コード Parts No.	ページ Page	Fig No.	部品コード Parts No.	ページ Page	Fig No.	部品コード Parts No.	ページ Page	Fig No.	部品コード Parts No.	ページ Page	Fig No.
M97320099	... P33	... S 118	MB60A0694	... P9	... E 111	MB62A0767	... P17	... J 138	ME10E0270	... P23	... M 901
M97321099	... P33	... S 901	MB60A0719	... P29	... Q 107	MB62A0777	... P33	... S 116	ME10E0452	... P11	... F 902
M97356099	... P23	... M 103	MB60A0740	... P11	... F 102	MB62A0921	... P19	... K 102	ME10E1830	... P3	... B 102
M98003015	... P11	... F 108	MB60A0750	... P3	... B 111	MB62A0950	... P21	... L 101	ME10E3601	... P23	... M 104
M99002022	... P19	... K 115	MB60A0915	... P23	... M 105	MB62A0957	... P21	... L 122	ME20A0406	... P9	... E 101
M99006063	... P5	... C 130	MB60A1368	... P29	... Q 106	MB62A0975	... P21	... L 104	ME20A1780	... P25	... N 132
	... P13	... G 114	MB60A1429	... P17	... J 115	MB62A1352	... P7	... D 114	ME20E0990	... P31	... R 901
MA04A1530	... P5	... C 104	MB60A1601	... P5	... C 118	MB62A1434	... P21	... L 105	ME25A0230	... P9	... E 121
MA10A0120	... P11	... F 121	MB60A1620	... P33	... S 111	MB62A1453	... P11	... F 132	ME25A0389	... P27	... P 107
MA10A0123	... P11	... F 119	MB60A1780	... P25	... N 128	MB62A1454	... P17	... J 128	ME25A0408	... P27	... P 108
	... P31	... R 102	MB60A1990	... P31	... R 106	MB62A1477	... P17	... J 109	ME25A0416	... P9	... E 145
MA10B2476	... P15	... H 125	MB60A2352	... P27	... P 118	MB62A1523	... P17	... J 142	ME25A0434	... P13	... G 153
MA10E0746	... P15	... H 117	MB60A2601	... P17	... J 116	MB62A1599	... P27	... P 121	ME25A0454	... P9	... E 139
MA16A0495	... P27	... P 127	MB60A2620	... P3	... B 141	MB62A1601	... P7	... D 102	ME25A0477	... P13	... G 149
MA16E0210	... P5	... C 904		... P33	... S 110	MB62A1762	... P35	... T 118	ME25A0484	... P27	... P 109
MA20A0194	... P5	... C 127	MB60A3957	... P29	... Q 109	MB62A1957	... P21	... L 119	ME25A0530	... P5	... C 110
MA20A0257	... P7	... D 103	MB60A5339	... P27	... P 110	MB62A2359	... P7	... D 111	ME25A0551	... P5	... C 107
MA20A0392	... P15	... H 134	MB60A5601	... P27	... P 113	MB62A2599	... P27	... P 122	ME25A0571	... P13	... G 152
MA20A0458	... P7	... D 105	MB60A5780	... P27	... P 111	MB62A2921	... P19	... K 112	ME25A0600	... P5	... C 101
MA20A0476	... P5	... C 105	MB60A6780	... P27	... P 112	MB62A4477	... P17	... J 118	ME25A0601	... P13	... G 151
MA20A0584	... P5	... C 141	MB60A8601	... P7	... D 106	MB62A4601	... P3	... B 122	ME25A0682	... P9	... E 141
MA20A0603	... P15	... H 113	MB60E0150	... P29	... Q 901	MB62A5352	... P7	... D 116	ME25A0692	... P19	... K 103
MA20A0613	... P31	... R 116	MB60E0234	... P9	... E 904	MB62A5454	... P19	... K 117	ME25A0738	... P13	... G 148
MA20A0650	... P19	... K 126	MB60E0682	... P9	... E 113	MB62A6339	... P7	... D 119	ME25A0781	... P19	... K 106
MA20A0734	... P33	... S 115	MB60E1682	... P9	... E 901	MB62A6352	... P7	... D 118	ME25A0921	... P19	... K 111
MA20A0740	... P11	... F 113	MB60E2148	... P25	... N 111	MB62E0131	... P33	... S 104	ME25A0950	... P5	... C 106
MA20A0980	... P23	... M 118	MB60E2750	... P5	... C 129	MB62E0148	... P25	... N 129	ME25A1454	... P13	... G 155
MA20A1780	... P25	... N 133	MB60E3339	... P23	... M 902	MB62E0450	... P11	... F 117	ME25A1833	... P9	... E 137
MA20A1910	... P15	... H 137	MB60E6339	... P3	... B 124	MB62E0599	... P27	... P 901	ME25A2339	... P27	... P 106
MA20A6571	... P27	... P 128	MB61A0436	... P23	... M 113	MB62E0776	... P33	... S 101	ME25E0190	... P5	... C 902
MA20A8571	... P27	... P 124	MB61A0571	... P17	... J 129	MB62E0849	... P3	... B 106	ME25E0331	... P9	... E 906
	... P33	... S 123	MB61A0601	... P3	... B 101	MB62E0956	... P11	... F 901	ME25E0688	... P25	... N 118
MA20E3688	... P25	... N 123	MB61A0767	... P17	... J 143	MB62E0957	... P17	... J 103	ME25E1688	... P25	... N 120
MA21P0454	... P17	... J 137	MB61A1454	... P17	... J 150	MB62E0975	... P15	... H 139	ME25E3688	... P25	... N 127
MA22A0477	... P21	... L 120	MB61A1477	... P21	... L 116	MB62E1148	... P25	... N 121	ME25Y0105	... P19	... K 901
MA22A2957	... P21	... L 121	MB61A2477	... P19	... K 125	MB62E2601	... P17	... J 104	ME25Y0272	... P19	... K 116
MA30A0571	... P31	... R 130	MB61A2767	... P17	... J 149	MB62E3105	... P35	... T 115	ME25Y0273	... P19	... K 124
MA35A0256	... P35	... T 109	MB61A3454	... P21	... L 102	MB62E3148	... P25	... N 110	ME25Y0339	... P7	... D 110
MA35A1256	... P35	... T 110	MB61A5601	... P33	... S 120	MB62E4148	... P25	... N 119	ME25Y0350	... P9	... E 124
MA35A2572	... P9	... E 138	MB61E0519	... P15	... H 114	ME03A0270	... P23	... M 119	ME25Y0407	... P17	... J 117
MA35A6758	... P17	... J 140	MB61E0982	... P23	... M 116	ME03A0838	... P15	... H 128	ME25Y0408	... P27	... P 105
MA45A0778	... P17	... J 135	MB61E1519	... P23	... M 106	ME03E5688	... P25	... N 122	ME25Y0454	... P19	... K 101
MB02A0608	... P31	... R 118	MB62A0263	... P21	... L 124	ME10A0148	... P11	... F 112	ME25Y0455	... P19	... K 114
MB02A1608	... P31	... R 117	MB62A0272	... P35	... T 116	ME10A0261	... P13	... G 103	ME25Y0470	... P3	... B 115
MB05E0519	... P15	... H 144	MB62A0339	... P3	... B 107	ME10A0572	... P13	... G 105	ME25Y0477	... P17	... J 112
MB25A0426	... P3	... B 116	MB62A0352	... P5	... C 131	ME10A0742	... P3	... B 104	ME25Y0595	... P29	... Q 101
MB45A0767	... P17	... J 126	MB62A0454	... P15	... H 132	ME10A0763	... P13	... G 111	ME25Y0691	... P31	... R 902
MB45A2476	... P17	... J 156	MB62A0456	... P17	... J 125	ME10A0833	... P11	... F 103	ME25Y0760	... P11	... F 116
MB60A0201	... P33	... S 113	MB62A0523	... P17	... J 134	ME10A0956	... P13	... G 124	ME25Y0797	... P33	... S 112
MB60A0366	... P27	... P 117	MB62A0572	... P21	... L 115	ME10A1101	... P15	... H 123	ME25Y0920	... P17	... J 111
MB60A0419	... P31	... R 104	MB62A0601	... P7	... D 107	ME10A1252	... P13	... G 142	ME25Y0957	... P17	... J 110
MB60A0420	... P33	... S 108	MB62A0626	... P13	... G 140	ME10A1780	... P25	... N 101	ME25Y0975	... P15	... H 153
MB60A0429	... P17	... J 119	MB62A0707	... P21	... L 108	ME10A1956	... P13	... G 118	ME25Y1339	... P7	... D 112
MB60A0560	... P31	... R 127	MB62A0757	... P27	... P 125	ME10A6910	... P13	... G 110	ME25Y1477	... P17	... J 155
MB60A0601	... P3	... B 126	MB62A0762	... P35	... T 117	ME10A7910	... P13	... G 112	ME25Y2339	... P7	... D 115

索引
INDEX-3

部品コード Parts No.	ページ Page	Fig No.	部品コード Parts No.	ページ Page	Fig No.	部品コード Parts No.	ページ Page	Fig No.	部品コード Parts No.	ページ Page	Fig No.
ME25Y3339	... P7	... D 117	MG43A0181	... P5	... C 150	MS02A1454	... P17	... J 154	MV30A0256	... P13	... G 141
	... P7	... D 120	MG50A0740	... P9	... E 114	MS02A1477	... P23	... M 114	MV30A1256	... P35	... T 105
ME26A0470	... P15	... H 120	MG51A0201	... P33	... S 114	MS02A1976	... P31	... R 113	MV35A0106	... P35	... T 106
ME26C0339	... P3	... B 134	MG75A0265	... P13	... G 135	MS02A2456	... P17	... J 139	MV88A0740	... P9	... E 116
ME26C0390	... P19	... K 105	MG75A1476	... P5	... C 111	MS02A2976	... P31	... R 112			
ME26C0484	... P27	... P 104	MM10A1479	... P31	... R 120	MS02A4729	... P23	... M 111			
ME26C0758	... P17	... J 145	MM11A0245	... P5	... C 115	MS02B0257	... P19	... K 119			
ME26C0920	... P17	... J 107	MM11A0352	... P11	... F 110	MS02E0460	... P13	... G 119			
ME40A0426	... P19	... K 123	MM11A0556	... P5	... C 152	MS02E0983	... P23	... M 110			
ME40A0571	... P13	... G 157	MM11A0702	... P5	... C 116	MS03A0101	... P35	... T 101			
ME40A0963	... P33	... S 122	MN10A0135	... P25	... N 107	MS03A0181	... P31	... R 110			
ME62C1758	... P17	... J 148	MN10A1456	... P9	... E 104	MS03A0256	... P35	... T 107			
MF00A0181	... P5	... C 145	MN10A3245	... P35	... T 113	MS03A0262	... P13	... G 138			
MF00A0608	... P31	... R 119	MN52A1245	... P5	... C 153	MS03A0417	... P5	... C 126			
MF00A2780	... P25	... N 106		... P31	... R 107		... P31	... R 103			
MF00E0550	... P5	... C 903	MN60A0620	... P3	... B 140	MS03A0703	... P13	... G 132			
MF01A0181	... P9	... E 131		... P25	... N 117	MS03A1256	... P35	... T 108			
MF01A0259	... P9	... E 107	MN60A0750	... P15	... H 110	MS03A1572	... P13	... G 134			
MF01A0476	... P9	... E 110	MN70A1780	... P13	... G 116	MS03A2101	... P35	... T 102			
MF01A0565	... P31	... R 108	MN72A1694	... P9	... E 109	MS03A2780	... P25	... N 113			
MF01A1476	... P9	... E 108	MS01A0121	... P11	... F 125	MS03A6154	... P13	... G 106			
MF10A0149	... P31	... R 121	MS01A0160	... P3	... B 132	MS03E0662	... P9	... E 134			
MF10A0181	... P5	... C 161	MS01A0192	... P15	... H 135	MS04E1210	... P35	... T 111			
MF10A0187	... P5	... C 156	MS01A0329	... P11	... F 127	MS05A0976	... P31	... R 133			
MF10A0267	... P13	... G 137	MS01A0348	... P15	... H 147	MS05A1976	... P31	... R 132			
MF10A0325	... P9	... E 135	MS01A0361	... P3	... B 119	MS06A0567	... P31	... R 128			
MF10A0553	... P5	... C 157	MS01A0383	... P9	... E 905	MS07A0228	... P15	... H 105			
MF10A0555	... P5	... C 114	MS01A0477	... P3	... B 133	MS08A0454	... P15	... H 156			
MF10A0709	... P5	... C 158	MS01A0508	... P11	... F 106	MS08A0616	... P11	... F 120			
MF10A1245	... P35	... T 112	MS01A0572	... P11	... F 131	MS08A0708	... P15	... H 154			
MF10A1555	... P5	... C 147	MS01A0611	... P11	... F 122	MS08A0740	... P25	... N 115			
MF10A2740	... P25	... N 102	MS01A0660	... P9	... E 126	MS09A0950	... P11	... F 124			
MF20A0130	... P33	... S 106	MS01A0663	... P9	... E 125	MS10A0232	... P9	... E 903			
MF21D0181	... P9	... E 128	MS01A0891	... P11	... F 109	MS10A0780	... P25	... N 131			
MF36A0245	... P5	... C 148	MS01A1392	... P15	... H 159	MS10A0976	... P31	... R 115			
MF36A0750	... P15	... H 103	MS01A1476	... P15	... H 124	MS10A0982	... P23	... M 115			
MF36A1180	... P5	... C 143	MS01A1572	... P15	... H 148	MS10A1456	... P3	... B 110			
MF40E0193	... P31	... R 105	MS01A1616	... P35	... T 103	MS10A1740	... P9	... E 115			
MF60A0700	... P13	... G 126	MS01A1739	... P3	... B 131	MS10A1976	... P31	... R 136			
MF60A0742	... P25	... N 103	MS01A1740	... P25	... N 112	MS10A2976	... P31	... R 137			
MF60A2740	... P9	... E 123	MS01A1976	... P31	... R 111	MS13A0572	... P19	... K 120			
MF60A5740	... P25	... N 125	MS01A2392	... P15	... H 157	MS14A0350	... P5	... C 121			
MF70A0350	... P13	... G 143	MS01A2572	... P15	... H 155	MS14A0553	... P5	... C 113			
MF70A1180	... P5	... C 159	MS01A3352	... P15	... H 901	MS14A0572	... P5	... C 124			
MF80A0352	... P9	... E 117	MS01A8796	... P25	... N 109	MS14A0682	... P9	... E 119			
MF80A0780	... P25	... N 114	MS01A9796	... P25	... N 130	MS14A0740	... P25	... N 126			
MF90A0361	... P15	... H 104	MS01E0351	... P15	... H 149	MS14A0838	... P15	... H 126			
MF90A0553	... P5	... C 146	MS01E0430	... P15	... H 140	MS14A1180	... P5	... C 112			
MF90A0976	... P31	... R 134	MS01E0580	... P9	... E 902	MS14A1620	... P25	... N 104			
MG30A0664	... P9	... E 127	MS02A0128	... P9	... E 129	MS14A3601	... P15	... H 143			
MG30A0740	... P13	... G 117		... P31	... R 101	MS14A3780	... P25	... N 124			
MG30A0760	... P13	... G 901	MS02A0463	... P13	... G 902	MS14E0180	... P5	... C 901			
MG30A0833	... P13	... G 120	MS02A0479	... P31	... R 135	MS17A0125	... P11	... F 118			
MG30B0226	... P13	... G 108	MS02A0778	... P19	... K 108	MS17A1120	... P35	... T 104			
MG30B0740	... P13	... G 127	MS02A0976	... P31	... R 114	MT60A0802	... P5	... C 154			

MEMO

A series of horizontal dashed lines for writing.



お問い合わせは下記へどうぞ

F A システム事業本部 機器計画部 駆動機器グループ 〒100-8310 東京都千代田区丸の内 2-7-3 (東京ビル)
代表電話番号 (03)3218-6631 代表 F A X 番号 (03)3218-6823



FACTORY AUTOMATION SYSTEM GROUP

2-7-3, Marunouchi Chiyoda-ku Tokyo 100-8310, Japan

Fax : +81-3-3218-6821