



三菱工業用ミシン部品カタログ

Industrial Sewing Machine Parts Catalog

Model PLK-J6040

目次	CONTENTS	Page
A 全体構成	Construction	1
B 本体関係 (1)	Arm bed & it's accessories (1)	2
C 本体関係 (2)	Arm bed & it's accessories (2)	4
D 本体関係 (3)	Arm bed & it's accessories (3)	6
E 本体関係 (4)	Arm bed & it's accessories (4)	8
F 縫い機構	Sewing mechanism	10
G デジタルテンション機構	Digital tension mechanism	12
H 中押え・ワイパー機構	Presser bar lifting mechanism & Wiper mechanism	14
J かま台機構	Hook saddle mechanism	16
K 糸切り機構	Thread trimming mechanism	18
L X-Yテーブル機構	X-Y table mechanism	20
M チャッキング装置	Jig eject system	22
N 配線配管関係	Cable component & Pneumatic control unit	24
P 給油機構	Oil lubrication mechanism	26
Q テーブル関係	Table & Stand	28
R 付属品	Accessories	30
S オプションパーツ	Option parts	32
索引	Index	34

部品コードの採番形式

MITSUBISHI SPARE PARTS No. Designation system

1. 部品コードについて CONCERNING PARTS CODE.

部品をご注文される場合は、部品コードをお知らせください。
Please inform the part number, when these parts are ordered.

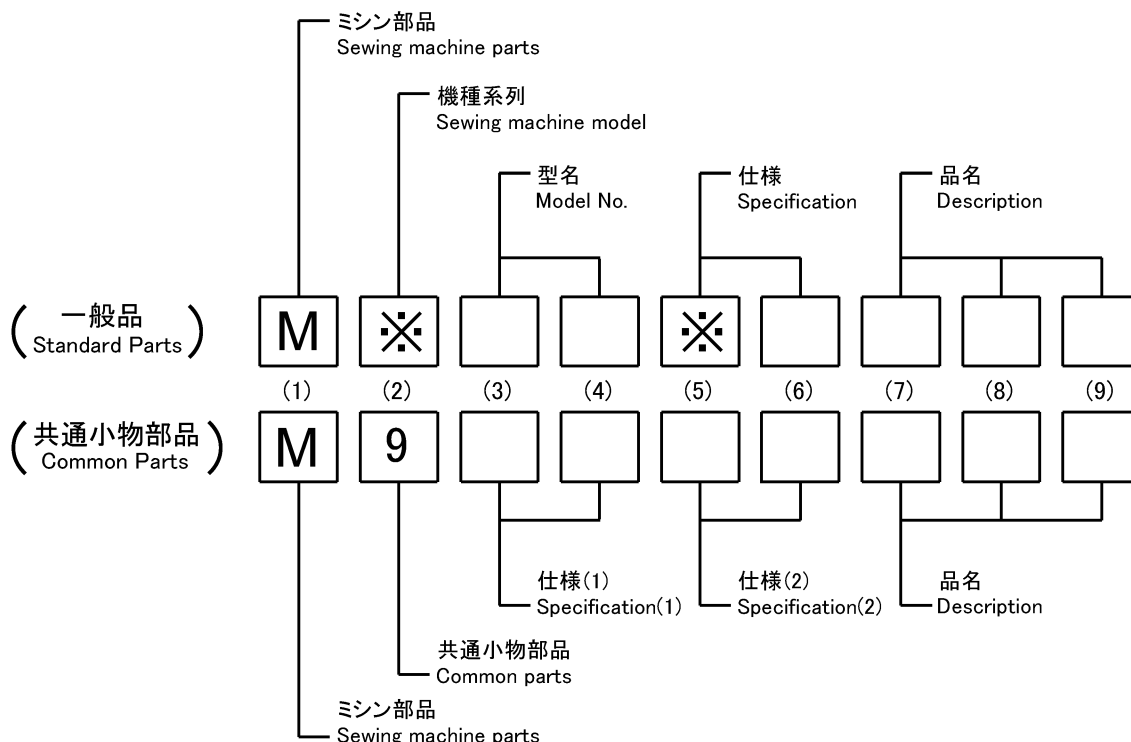

[例] Example

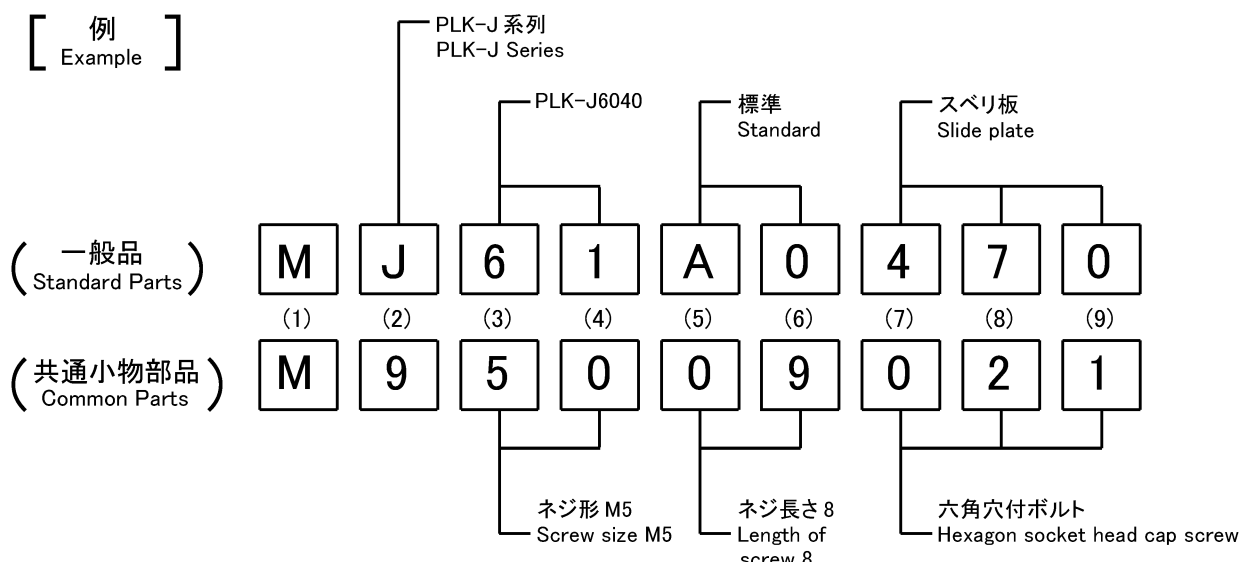

2. 変更マークについて CONCERNING MODIFICATION MARK.

変更マーク欄に * 記号のある部品は、形状、寸法などの変更履歴がありますので、ご注文の際にはご使用の製品の製造番号と合わせてご覧ください。

The parts marked with * in the modification column has been changed the shape or size etc. So when these modified parts are ordered please inform the serial number of the sewing machine.

注：一般品についての機種型名は、その部品が最初に使用された機種型名を示します。従って長期にわたる場合は、機種の改廃が行われるため、当初の機種以外の機種で使用されている場合があります。

Sewing machine Models, of Standard Parts are Indicated model of these parts are registered firstly. Parts are used for not only the indicated model, but also another models, in reason of New development, improvement after.

A 全体構成
CONSTRUCTION

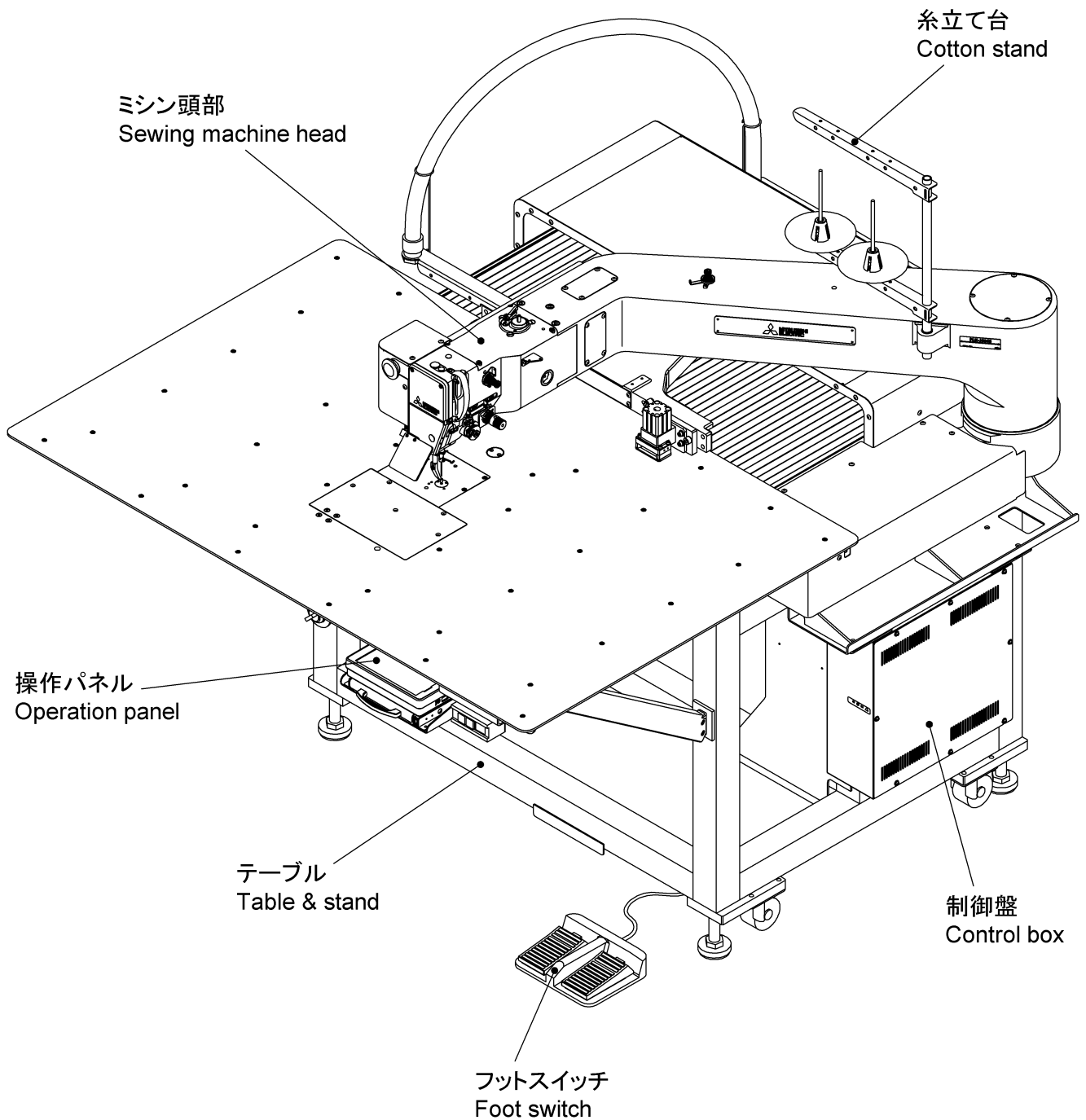

注1 : Fig.No.の採番していない部品は単体で支給することは出来ません。セットにて支給いたします。

Remarks 1) The parts which Fig.No. are not marked are not available individually.
It can be supplied with the whole component.

B 本体関係 (1)
ARM BED & IT'S ACCESSORIES (1)

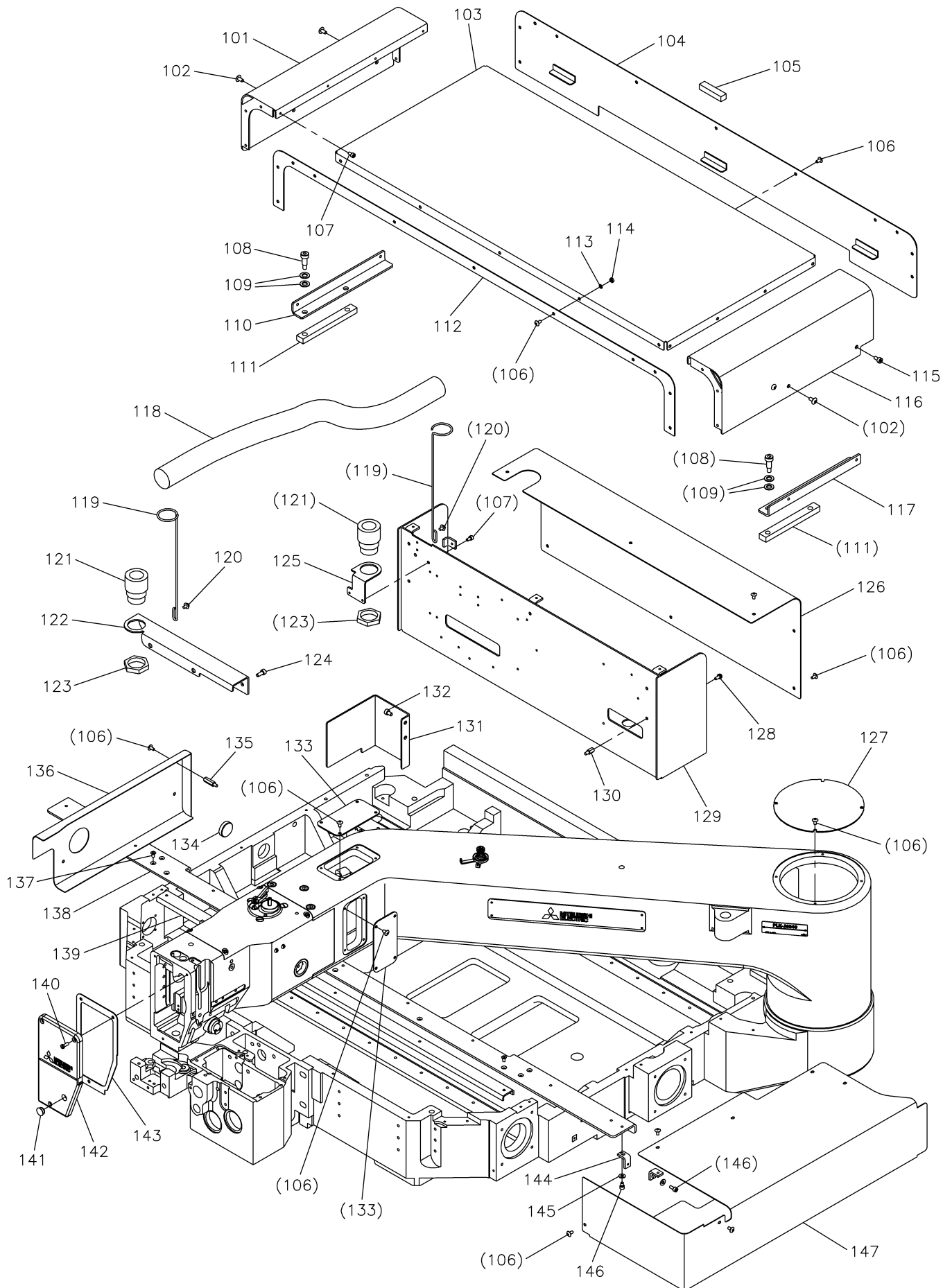

[B] 本体関係(1)

ARM BED & IT'S ACCESSORIES (1)

Fig no.	変更 Mod.	部品コード Parts no.	品名	Description	数量 Amt. Req.
B 101		MJ60A1339	X-Yカバー ヒタリ	X-Y cover (left)	1
☆ B 102		M90503036	PTラスネジ M5X10	Truss screw M5X10	3
B 103		MJ60A2339	X-Yカバー ウエ	X-Y cover (upper)	1
B 104		MJ60A4339	X-Yカバー ウシロ	X-Y cover (rear)	1
B 105		MJ60A0416	ゴムイタ A	Rubber plate A	3
☆ B 106		M90403036	トラスネジ M4X8	Truss screw M4X8	52
☆ B 107		M94008017	セフティソケット M4X6	Safety socket bolt M4X6	10
B 108		M98002031	ストリッパホルト	Stripper bolt	4
B 109		M90825050	コサガネ 8	Small washer 8	8
B 110		MJ60A2601	X-Yカバー トリツケイタ ヒタリ	X-Y cover adapter (left)	1
B 111		MJ60A1416	ゴムイタ B	Rubber plate B	2
B 112		MJ60A3339	X-Yカバー マエ	X-Y cover (front)	1
☆ B 113		M90422050	コサガネ 4	Small washer 4	10
☆ B 114		M91007045	ナット M4	Nut M4	10
☆ B 115		M95053021	ロッカクアナツキホルト M5X6	Socket bolt M5X6	1
B 116		MJ60A0339	X-Yカバー クミタテ ミキ	X-Y cover assy (right)	1
B 117		MJ60A1601	X-Yカバー トリツケイタ ミキ	X-Y cover adapter (right)	1
B 118		MJ60A0567	フレキシブルチューブ	Flexible tube	1
B 119		MJ60A1780	ホルダクミタテ	Holder assy	2
☆ B 120		M91071004	SW-MW プライマナネジ M4X8	SW-MW pan screw M4X8	4
B 121		MJ60A1422	コネクター	Connector	2
B 122		MJ60A0601	コネクタトリツケイタ	Connector bracket	1
B 123		M95025045	ロッカクナット	Nut	2
☆ B 124		M95003021	ロッカクアナツキホルト M5X12	Socket bolt M5X12	2
B 125		MJ60B1601	コネクタトリツケイタ	Connector bracket	1
B 126		MJ60A7339	キバンボックスカバー	Print circuit board box cover	1
B 127		MJ60A1742	アームフタ	Arm cover	1
☆ B 128		K14S90203410	SW-PW Pナネジ M4X10	SW-PW pan screw M4X10	5
B 129		MJ60A0696	キバンボックス	Print circuit board box	1
B 130		MJ60A2476	スペーサホルト	Spacer bolt	5
B 131		MJ60A8339	カバー	Cover	1
B 132		M95009021	ロッカクアナツキホルト M5X8	Socket bolt M5X8	2
B 133		MJ60B3339	アームカバー	Arm cover	2
B 134		MJ60A1500	ゴムセン φ33.5	Rubber plug φ33.5	1
B 135		MJ60A4476	スペーサホルト	Spacer bolt	4
B 136		MJ60A5339	アームソクメンカバー	Cover	1
☆ B 137		M90449037	Pサラネジ M4X8	Countersunk screw M4X8	9
B 138		MJ60A0799	ホキョウイタ ウシロ	Stiffening plate (rear)	1
B 139		MJ60A0161	ウラアテイタ	Stiffening plate (back)	1
☆ B 140		M90991002	ヒラネジ M4X12	Flat screw M4X12	3
☆ B 141		M91182080	セン φ11.8	Rubber plug φ11.8	1
B 142		MJ60A0830	メンイタ	Face cover	1
B 143		MJ60A0691	ガスケット	Gasket	1
☆ B 144		MB62A4601	トリツケイタ	Adapter	2
☆ B 145		M90421050	ミカキサガネ 4	Large washer 4	2
☆ B 146		M94002017	セフティソケット M4X8	Safety socket bolt M4X8	2
B 147		MJ60A0849	モータカバー	Motor cover	1

C 本体関係 (2)
ARM BED & IT'S ACCESSORIES (2)

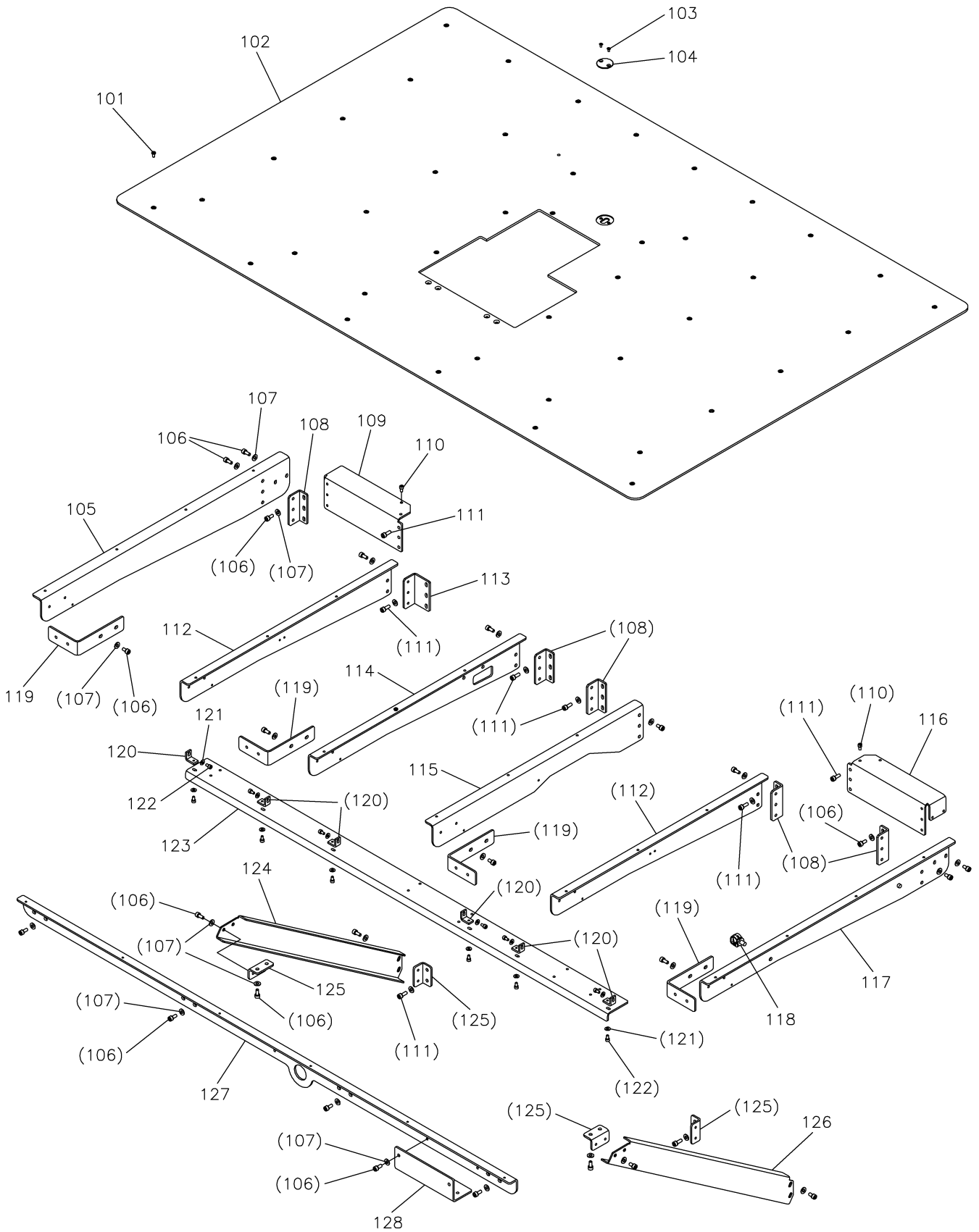

[C] 本体関係(2)

ARM BED & IT'S ACCESSORIES (2)

Fig no.	変更 Mod.	部品コード Parts no.	品名	Description	数量 Amt. Req.
☆ C 101		M90990002	ヒラネジ M4X8	Flat screw M4X8	41
C 102		MJ61A0470	スベリ板	Slide plate	1
☆ C 103		M91304010	Pサラネジ M3X6	Countersunk screw M3X6	2
C 104		MJ61A0742	チョウセイフタ	Adjustment cover	1
C 105		MJ60A3429	サエカナグ D	Bracket D	1
☆ C 106		M95005017	セフティソケット M5X10	Safety socket bolt M5X10	58
☆ C 107		M90511050	ミキサガネ 5	Large washer 5	74
☆ C 108		MA20A0361	Lカタカナグ	L-type bracket	5
C 109		MJ60A2758	サエカナグブラケット ヒダリ	Bracket (left)	1
☆ C 110		M94001017	セフティソケット M4X10	Safety socket bolt M4X10	4
☆ C 111		M95002017	セフティソケット M5X12	Safety socket bolt M5X12	22
C 112		MJ60A1429	サエカナグ B	Bracket B	2
☆ C 113		ME60A0361	Lカタカナグ	L-type bracket	1
C 114		MJ60A4429	サエカナグ E	Bracket E	1
C 115		MJ60A0429	サエカナグ A	Bracket A	1
C 116		MJ60A1758	サエカナグブラケット ミキ	Bracket (right)	1
C 117		MJ60A2429	サエカナグ C	Bracket C	1
☆ C 118		MH40A1620	ホルダクリップ	Holder clip	2
☆ C 119		ME40A0758	ブラケット	Bracket	4
☆ C 120		MB62A4601	トリツケイタ	Adapter	6
☆ C 121		M90421050	ミキサガネ 4	Large washer 4	12
☆ C 122		M94002017	セフティソケット M4X8	Safety socket bolt M4X8	12
C 123		MJ60A0426	サポート2	Supporter 2	1
C 124		MJ60A2426	サポート1 ヒダリ	Supporter 1 (left)	1
☆ C 125		ME60A1361	Lカタカナグ	L-type bracket	4
C 126		MJ60A1426	サポート1 ミキ	Supporter 1 (right)	1
C 127		MJ60A1799	ホキョウイタ マエ	Stiffening plate (front)	1
C 128		MJ60B2601	SWトリツケイタ	Switch adapter	1

D 本体関係 (3)
ARM BED & IT'S ACCESSORIES (3)

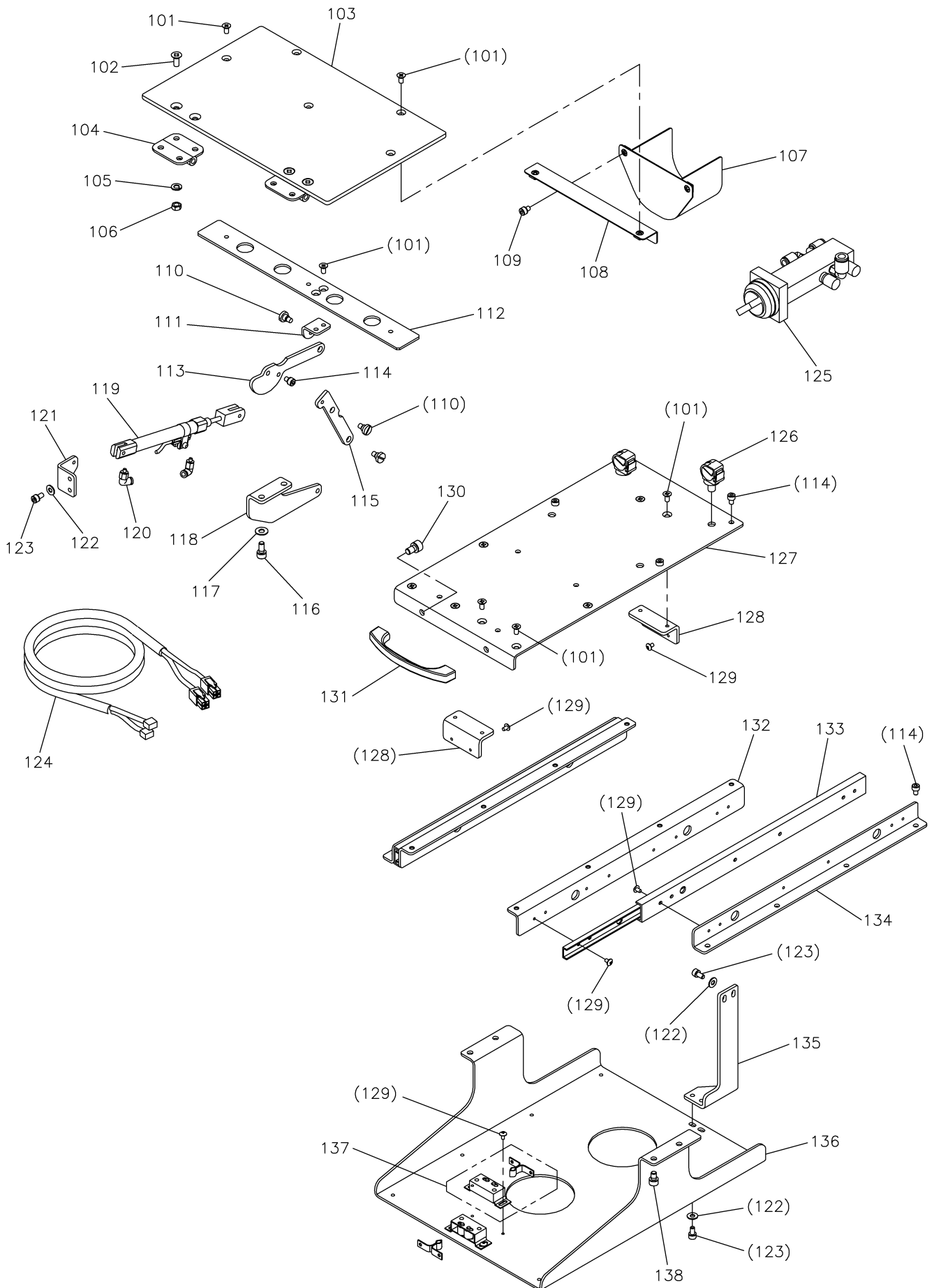

[D] 本体関係(3)

ARM BED & IT'S ACCESSORIES (3)

Fig no.	変更 Mod.	部品コード Parts no.	品名	Description	数量 Amt. Req.
☆ D 101		M90449037	Pサラネジ M4X8	Countersunk screw M4X8	15
D 102		M90522037	Pサラネジ M5X10	Countersunk screw M5X10	8
D 103		MJ61A3742	スベリイタ フタ	Flap plate	1
D 104		MH50A0739	ヒンジ	Hinge	2
D 105		M90522050	サラネサガネ 5	Conical spring washer 5	8
D 106		M91384045	トメナット M5	Nut M5	8
D 107		MJ61A0339	ショウメンカマカバー-A	Hook cover A	1
D 108		MJ61A1339	ショウメンカマカバー-B	Hook cover B	1
☆ D 109		M94008017	セフティソケット M4X6	Safety socket bolt M4X6	2
☆ D 110		M91127015	ヒラネジダンツキ 11/64(40)X5	Shoulder bolt 11/64(40)X5	3
D 111		MJ60A0739	ヒンジ1	Hinge 1	1
D 112		MJ60A0237	カイヘイウライタ	Stopper plate	1
D 113		MJ60A1910	リンク1	Link 1	1
☆ D 114		M94001021	ロッカクアナツキホルト M4X6	Socket bolt M4X6	13
D 115		MJ60A2910	リンク2	Link 2	1
☆ D 116		M95005017	セフティソケット M5X10	Safety socket bolt M5X10	2
☆ D 117		M90511050	ミカキサガネ 5	Washer 5	2
D 118		MJ60A1739	ヒンジ2	Hinge 2	1
D 119		MJ60A0434	エアシリンダ	Air cylinder	1
D 120		MB61A1571	エルボユニオン	Connector	2
D 121		MJ60A8601	シリンダトリツケイタ	Cylinder bracket	1
☆ D 122		M90421050	ミカキサガネ 4	Large washer 4	6
☆ D 123		M94002017	セフティソケット M4X8	Safety socket bolt M4X8	6
D 124		MJ60A8508	ケーブル(ホビンマト/イトキリセンサ)	Cable (flap plate/TRIM sensor)	1
D 125		MJ60A1599	メカニカルバルブ	Mechanical operated valve	1
☆ D 126		MH40A0620	ホルダクリップ	Holder clip	2
D 127		MJ60A0595	レールテンイタ	Top panel	1
☆ D 128		MH40A2601	ウケトリツケイタ	Bracket	2
☆ D 129		M90302036	トラスコネジ M3X5	Truss screw M3X5	32
☆ D 130		M96008017	セフティソケット M6X10	Safety socket bolt M6X10	2
D 131		MJ60A0602	トッテ	Handle	1
☆ D 132		MH40A1958	レールウエ	Rail (upper)	2
☆ D 133		MH40A2958	スライドレール	Slide rail	2
☆ D 134		MH40A0958	レールシタ	Rail (lower)	2
D 135		MJ60A2799	ホキョウイタ	Stiffening plate	1
D 136		MJ60A1770	PALトリツケベース	PAL base	1
☆ D 137		MH40A0809	ローラーキャッチ	Roller catch	2
☆ D 138		M95003017	セフティソケット M5X8	Safety socket bolt M5X8	4

E 本体関係 (4)
ARM BED & IT'S ACCESSORIES (4)

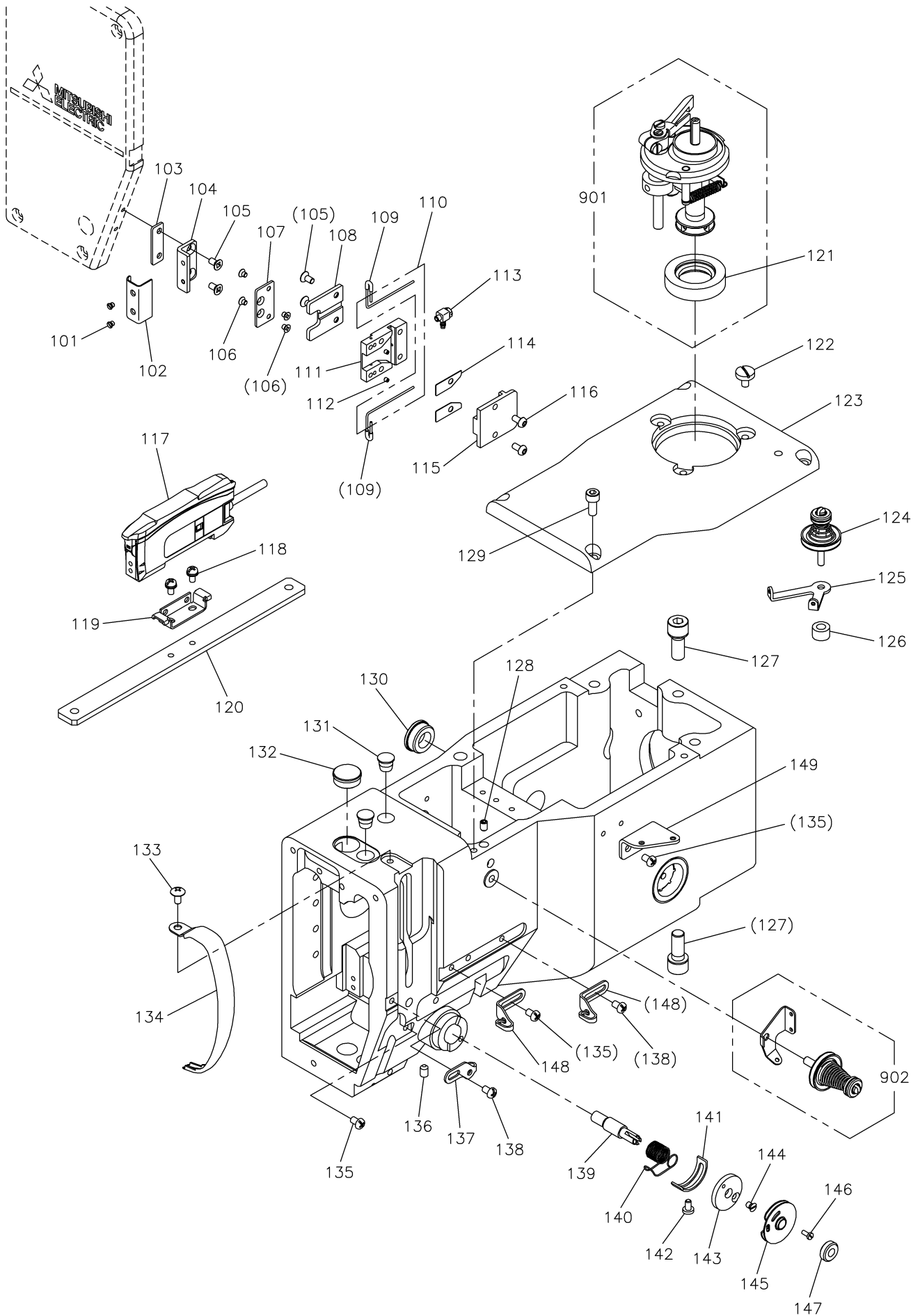

[E] 本体関係(4)

ARM BED & IT'S ACCESSORIES (4)

Fig no.	変更 Mod.	部品コード Parts no.	品名	Description	数量 Amt. Req.
☆ E 101		M90605010	サラネジ 2/32(56)X2.8	Countersunk screw 2/32(56)X2.8	2
E 102		MJ61A2339	カバー	Cover	1
E 103		MJ61A0476	ベーススペーサ	Base spacer	1
E 104		MJ61A0758	ブラケット	Bracket	1
E 105		M90858004	Pサラネジ M3X6	Countersunk screw M3X6	4
E 106		M92000010	サラネジ M2.5X3	Countersunk screw M2.5X3	4
E 107		MJ61A0601	トリツケイタ	Adapter	1
E 108		MJ61A0770	ハイセンベース	Wiring base	1
E 109		MJ61A0567	ビニールチューブ	Tube	2
E 110		MJ61A0757	ファイバユニット	Optical fiber unit	1
E 111		MJ61A1770	メインベース	Main base	1
E 112		M92004020	ロッカアナツキメネジ M2X2	Set screw M2X2	2
E 113		MJ61A0571	カンツキテ	Connector	1
E 114		MJ61A1476	スペーサ	Spacer	2
E 115		MJ61A1742	ベースフタ	Base cover	1
E 116		M93000022	ロッカアナツキボタンホルト M3X6	Button bolt M3X6	2
E 117		MJ61A1757	ファイバアンプミタテ	Optical fiber amplifier assy	1
☆ E 118		M90859004	SW-PWプラマイナネジ M3X6	SW-PW pan screw M3X6	2
E 119		MJ61A0602	トリツケカナグ	Holder	1
E 120		MJ61A1601	アンプトリツケイタ	Amplifier adapter plate	1
E 121		MH10A0417	ゴムワ	Rubber ring	1
E 122		M91150003	マルヒラネジ 11/64(40)X8	Flat screw 11/64(40)X8	3
E 123		MJ60A0600	トップカバー	Top cover	1
E 124		MH25E0210	チョウセツキクミタテ	Thread tension Regulator assy	1
☆ E 125		MS14A1180	イトアンナイ	Thread guide	1
E 126		MH25A1476	スペーサ	Spacer	1
E 127		M98004017	セフティソケット M8X20	Safety socket bolt M8X20	6
☆ E 128		M91053020	ロッカアナツキメネジ M4X6	Set screw M4X6	1
☆ E 129		M95003021	ロッカアナツキホルト M5X12	Socket bolt M5X12	4
☆ E 130		M91910080	ゴムセン φ19	Rubber plug φ19	1
☆ E 131		M90883080	ゴムセン φ8.8	Rubber plug φ8.8	2
E 132		MJ60A0500	ゴムセン φ17	Rubber plug φ17	1
☆ E 133		M90403036	トラスネジ M4X8	Truss screw M4X8	1
E 134		MH10A0584	テンヒンカバー	Thread take-up lever guard	1
☆ E 135		M91011004	プラマイナネジ M4X6	Pan screw M4X6	4
E 136		M91051020	ロッカアナツキメネジ M4X8	Set screw M4X8	1
☆ E 137		MH10A0181	イトアンナイ	Thread guide	1
E 138		M91084004	プラマイナネジ M4X6	Pan screw M4X6	2
E 139		MP10B0554	チョウジク	Thread tension stud	1
E 140		MP60A1187	イトリハネ	Thread take-up spring	1
E 141		MN10A0477	ストッパ	Stopper	1
☆ E 142		M90920002	ヒラネジ 9/64(40)X6.5	Flat screw 9/64(40)X6.5	1
E 143		MJ60A6770	イトリベース	Thread take-up base	1
E 144		M90907010	サラネジ 9/64(40)X5	Countersunk screw 9/64(40)X5	1
E 145		MN10E0175	イタクミタテ	Plate complete	1
E 146		M90602003	マルヒラネジ 3/32(56)X6	Flat screw 3/32(56)X6	1
E 147		M91603046	ツマミナット	Thumb nut	1
☆ E 148		MG43A0181	イトアンナイ	Thread guide	2
E 149		MH10A3181	イトアンナイ	Thread guide	1
E 901		MJ61E0190	イトマキソウチクミタテ	Bobbin winder complete	1
☆ E 902		MH10E0550	イトチョウセツキクミタテ	Thread tension Regulator assy	1

☆印はPLK-G6030共通部品を示します。

☆ indicates PLK-G6030 common parts.

F 縫い機構
SEWING MECHANISM

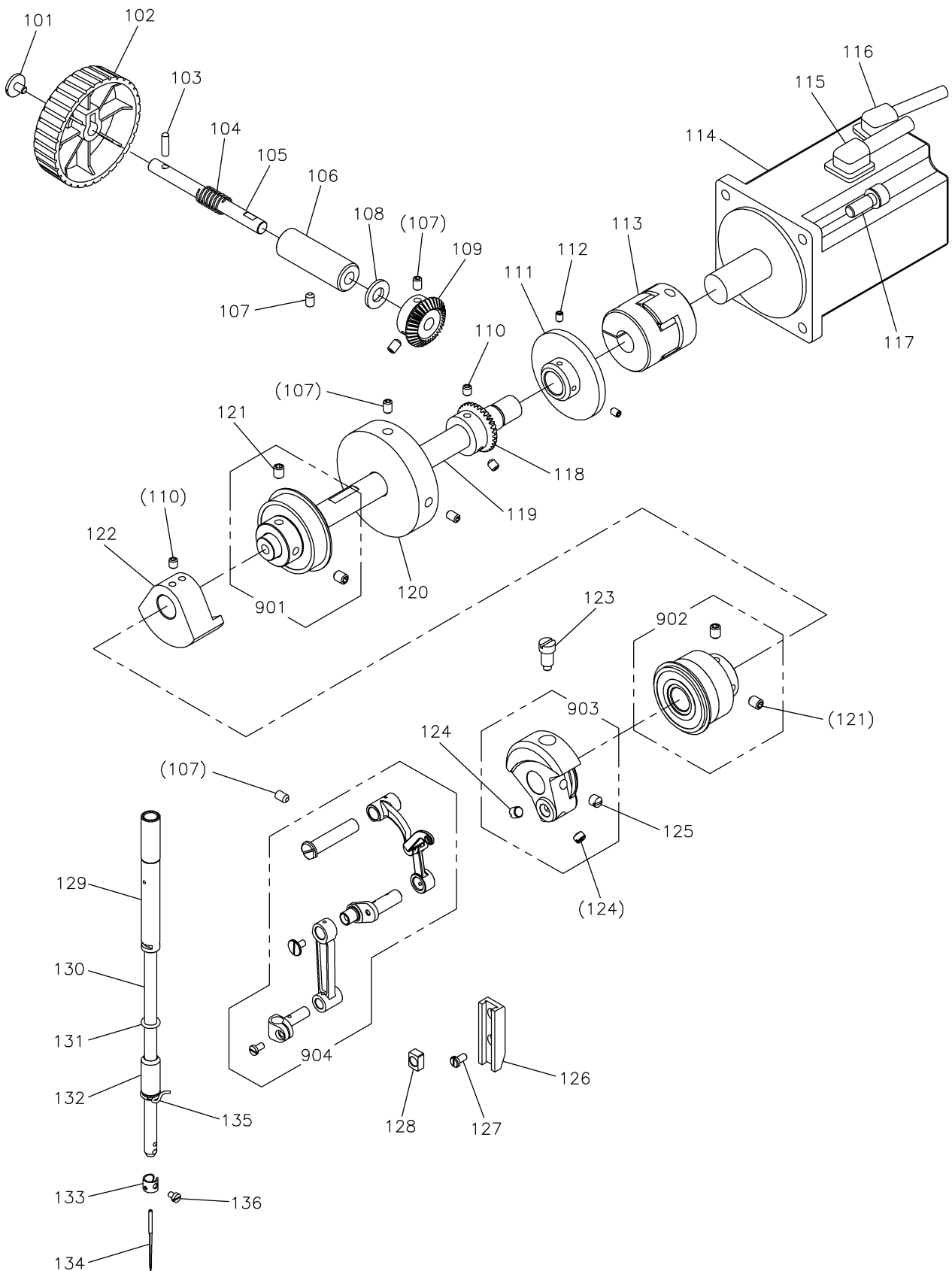

[F]縫い機構

SEWING MECHANISM

Fig no.	変更 Mod.	部品コード Parts no.	品名	Description	数量 Amt. Req.
☆ F 101		M91119002	ヒラネジ 11/64(40)X6.8	Flat screw 11/64(40)X6.8	1
F 102		MJ60A0682	プーリー	Hand pulley	1
☆ F 103		M90406064	スプリングピン 4X14	Spring pin ϕ 4X14	1
☆ F 104		MH10A0572	ツルマキバネ	Spring	1
F 105		MH10A0454	シク	Shaft	1
F 106		MH10A0833	メタル	Bushing	1
☆ F 107		M95004020	ロッカクアナツキトメネジ M5X8	Set screw M5X8	6
☆ F 108		MH10A0416	カンショウゴム	Rubber cushion	1
☆ F 109		MH10A0722	マイタキヤ	Gear	1
☆ F 110		M95002020	ロッカクアナツキトメネジ M5X6	Set screw M5X6	4
☆ F 111		MS14A0682	プーリー	Pulley	1
☆ F 112		M91053020	ロッカクアナツキトメネジ M4X6	Set screw M4X6	2
F 113		MJ60A0364	カップリング	Coupling	1
F 114		MJ60A2848	サーボモータ(シュシク)	Servomotor (upper shaft)	1
F 115		MJ60A9508	ケーブル(シュシクモータテンゲン)	Cable (upper shaft moter power)	1
F 116		MJ60A0508	ケーブル(シュシクモータエンコーダ)	Cable (upper shaft moter encoder)	1
☆ F 117		M96001017	セフテイソケット M6X16	Safety socket bolt M6X16	4
☆ F 118		MH10A1722	ウワジクマイタキヤ	Gear	1
F 119		MJ60A0230	ウワジク	Upper shaft	1
F 120		MJ60A0383	イナーシャ	Inertia rotor	1
☆ F 121		M91650020	ロッカクアナツキトメネジ M6X8	Set screw M6X8	4
F 122		MJ60A0721	バランス	Balance weight	1
☆ F 123		M91802006	ヒラネジホウサキ 9/32(28)	Set screw 9/32(28)	1
☆ F 124		M91606001	トメネジ 1/4(40)X6	Set screw 1/4(40)X6	2
☆ F 125		M91602001	トメネジ 1/4(40)X4	Set screw 1/4(40)X4	1
☆ F 126		MS01A0155	アンナイダイ	Guide bracket	1
☆ F 127		M90990002	ヒラネジ M4X8	Flat screw M4X8	2
☆ F 128		MF10A0325	カクコマ	Square block	1
☆ F 129		MH10A0663	ハリホウメタルウエ	Needle bar bushing (upper)	1
☆ F 130		MS01A0660	ハリホウ	Needle bar	1
☆ F 131		M90500085	リング	O-ring	1
F 132		MJ60A0664	ハリホウメタルシタ	Needle bar bushing (lower)	1
☆ F 133		MF21D0181	イトアンナイ	Thread guide	1
☆ F 134		MS02A0128	ミシンハリ DPX17-18	Needle DPX17 #18	1
☆ F 135		MF01A0181	イトアンナイ	Thread guide	1
☆ F 136		M90815002	ヒラネジ 1/8(44)X4.5	Flat screw 1/8(44)X4.5	1
F 901		MJ60E0456	シクウケクミタテ(ウワジクウシロ)	Ball bearing assy (rear)	1
F 902		MH10E0456	シクウケクミタテ(ウワジクマエ)	Ball bearing assy (front)	1
☆ F 903		MS01A0383	クランクミタテ	Crank assy	1
☆ F 904		MS01E0580	テンピンハリクミタテ	Thread take-up lever assy	1

G デジタルテンション機構
DIGITAL TENSION MECHANISM

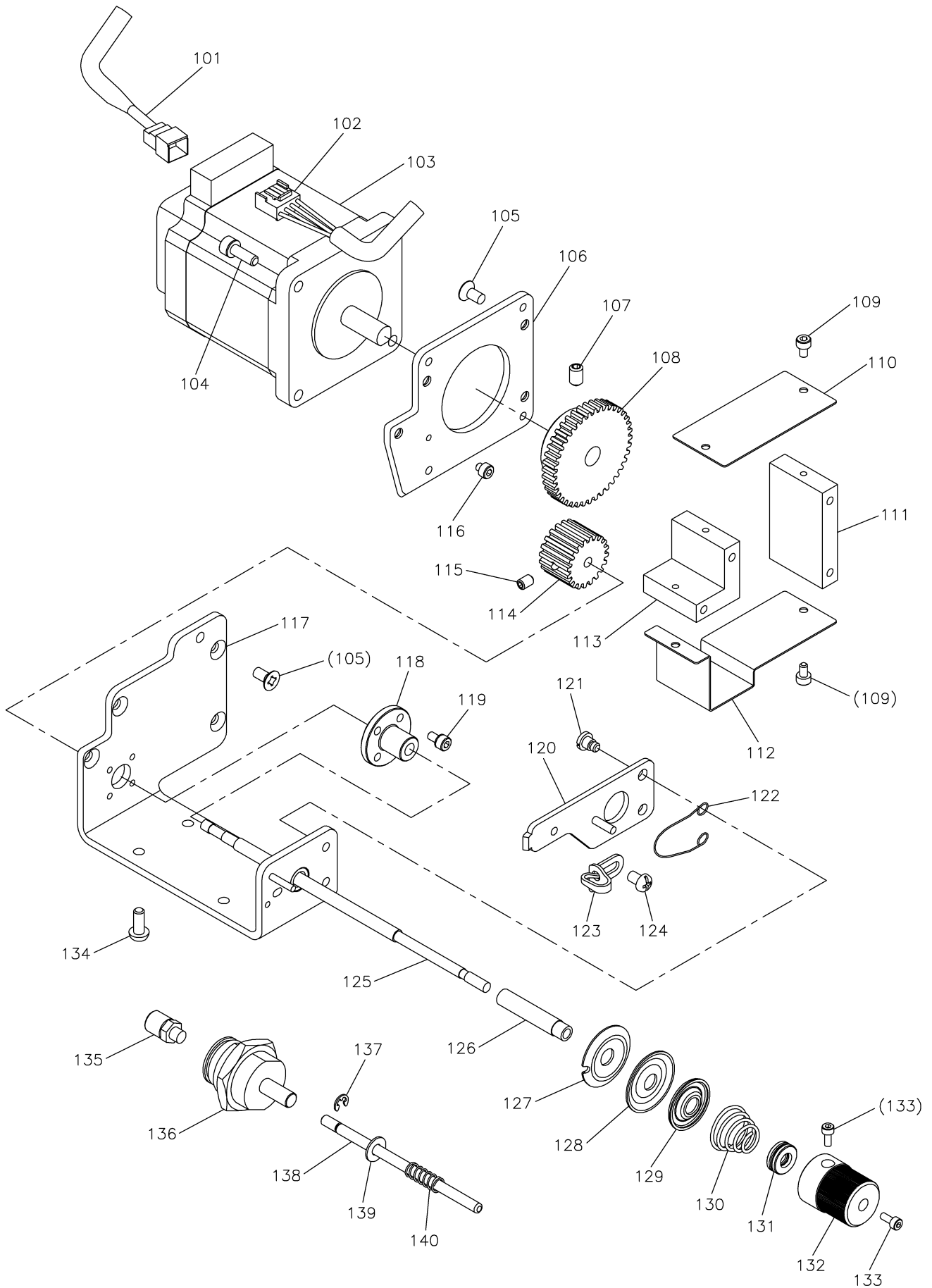

[G] デジタルテンション機構
DIGITAL TENSION MECHANISM

Fig no.	変更 Mod.	部品コード Parts no.	品名	Description	数量 Amt. Req.
G 101		MJ60A7508	ケーブル(PF/DTモータエンコーダ)	Cable (PF/DT moter encoder)	1
G 102		MJ60A6508	ケーブル(PF/DTモータテンゲン)	Cable (PF/DT moter power)	1
G 103		MH13A0848	ステップモータ	Stepping motor	1
☆ G 104		M94007017	セフティソケット M4X12	Safety socket bolt M4X12	4
☆ G 105		M91400010	Pサラネジ M4X8	Countersunk screw M4X8	8
G 106		MJ60A5770	モータベース	Motor base	1
☆ G 107		M95004020	ロッカアナツキメネジ M5X8	Set screw M5X8	1
G 108		MJ60A1722	ヒラハグルマ	Gear	1
☆ G 109		M93003021	ロッカアナツキホルト M3X6	Socket bolt M3X6	4
G 110		MJ60A9339	カバーA	Cover A	1
G 111		MJ60A1751	モータブロックA	Motor block A	1
G 112		MJ60B0339	カバーB	Cover B	1
G 113		MJ60A2751	モータブロックB	Motor block B	1
G 114		MJ60A0722	ヒラハグルマクミタテ	Gear assy	1
☆ G 115		M91053020	ロッカアナツキメネジ M4X6	Set screw M4X6	1
G 116		M93022021	ロッカアナツキホルト M3X3	Socket bolt M3X3	1
G 117		MJ60A0770	ユニットベースクミタテ	Unit base assy	1
G 118		M92453047	ショウケイオクリネジナット	Feed screw nut	1
G 119		M94003017	セフティソケット M3X6	Safety socket bolt M3X6	4
G 120		MJ60A0220	イトルメイタクミタテ	Tension releasing plate assy	1
G 121		M90902015	ヒラネジダツキ 9/64(40)X3	Shoulder bolt 9/64(40)X3	2
G 122		MJ60A0851	モトシハネ	Reverse spring	1
G 123		MG43A1181	イトアンナイ	Thread guide	1
☆ G 124		M91011004	フラマイナネジ M4X6	Pan screw M4X6	1
G 125		MJ60A0471	スベリネジ	Slide screw	1
G 126		MJ60A0482	チョウシスリーブ	Thread tension sleep	1
G 127		ML10A0555	チョウシガラ	Thread tension disc	1
☆ G 128		MF10A0555	チョウシガラ	Thread tension disc	1
G 129		MJ60A0556	チョウシガラオサエ	Thread tension releasing disc	1
G 130		MJ60A0245	エンスイハネ φ1.2	Thread tension spring φ1.2	1
G 131		MJ60A4456	スラストタマシクウケ	Thrust ball bearing	1
G 132		MJ60A0573	ツマミ	Thumb nut	1
G 133		M92001021	ロッカアナツキホルト M2.5X6	Socket bolt M2.5X6	2
G 134		M94036021	ロッカアナツキボタンホルト M4X10	Button bolt M4X10	4
G 135		MJ60A0625	ホースニップル	Hose nipple	1
G 136		MJ60A1434	ピンシリンダ	Pin cylinder	1
☆ G 137		M90512065	Eタイプメワ 3	E-type retaining ring 3	1
G 138		M90434060	ピン	Pin	1
☆ G 139		M90421050	ミキサガネ 4	Large washer 4	1
☆ G 140		MH10A2701	ハネ	Spring	1

H 中押え・ワイパー機構
PRESSER BAR LIFTING & WIPER MECHANISM

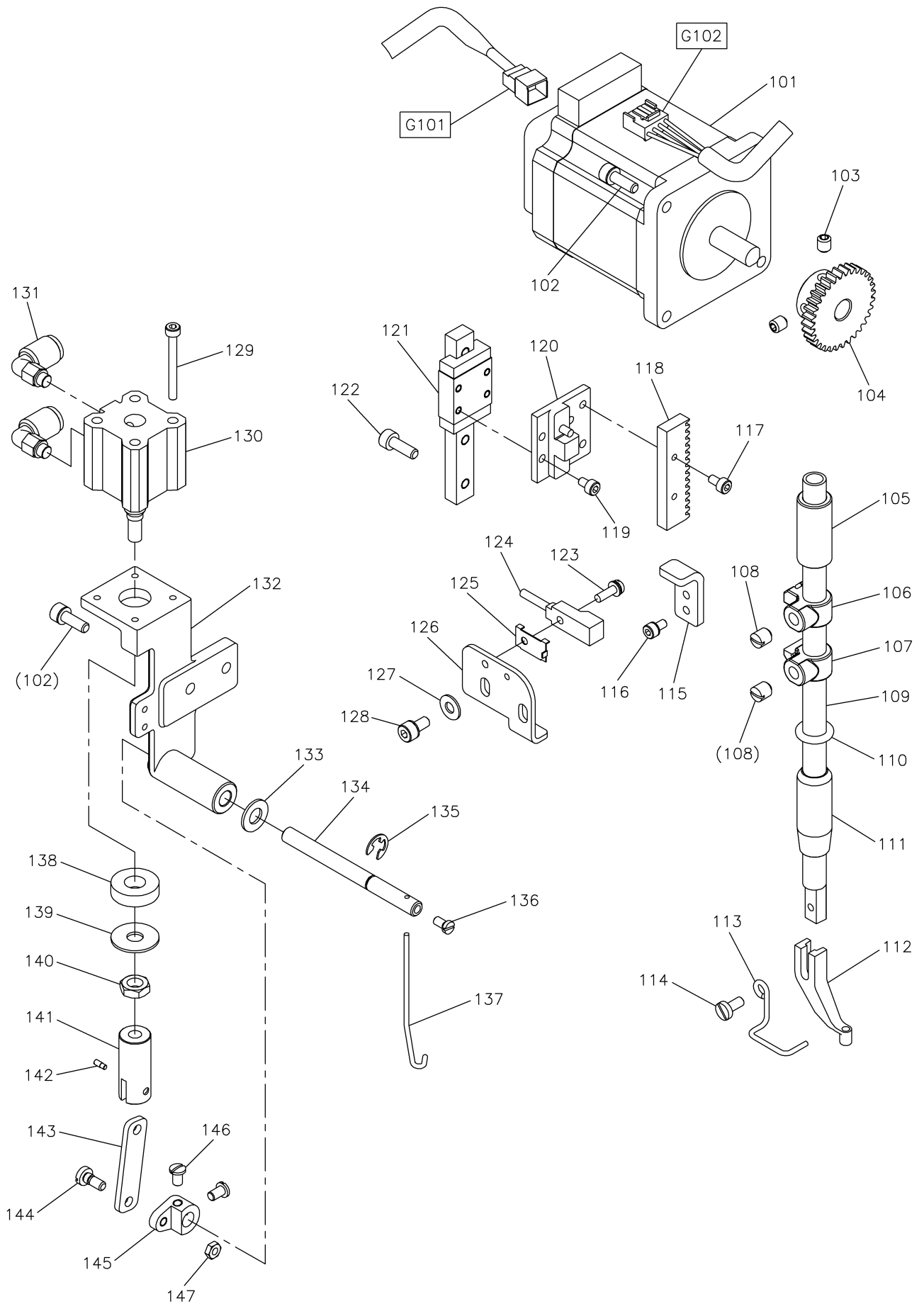

[H] 中押し・ワイパー機構

PRESSER BAR LIFTING & WIPER MECHANISM

Fig no.	変更 Mod.	部品コード Parts no.	品名	Description	数量 Amt. Req.
H 101		MJ60A0848	ステッピングモータ	Stepping motor	1
☆ H 102		M94007017	セフティソケット M4X12	Safety socket bolt M4X12	6
☆ H 103		M94001001	ナイロックトメネジ M5X6	Set screw M5X6	2
H 104		MJ60A2722	ヒラハグルマ	Gear	1
H 105		MJ60A0267	オサエホウメタル ウエ	Presser bar bushing (upper)	1
H 106		MJ60A0751	ナカオサエジョウゲブロック A	Presser bar lifting block A	1
H 107		MJ60A3751	ナカオサエジョウゲブロック B	Presser bar lifting block B	1
☆ H 108		M91506001	トメネジ 15/64(28)X7	Set screw 15/64(28)X7	2
H 109		MJ60A0262	オサエホウ	Presser bar	1
☆ H 110		M90600085	リング	O-ring	1
☆ H 111		MH10A0267	オサエホウメタル シタ	Presser bar bushing (lower)	1
☆ H 112		MV30A0256	オサエ φ3	Presser foot φ3	1
☆ H 113		MH10A0626	ニードルガード	Needle guard	1
☆ H 114		M90922002	ヒラネジ 9/64(40)X8	Flat screw 9/64(40)X8	1
H 115		MJ60A0477	ストップ	Stopper	1
H 116		M94012017	セフティソケット M3X8	Safety socket bolt M3X8	2
☆ H 117		M93002021	ロッカアナツキホルト M3X8	Socket bolt M3X8	2
H 118		MJ60A0901	ラック	Rack	1
☆ H 119		M93003021	ロッカアナツキホルト M3X6	Socket bolt M3X6	4
H 120		MJ60A2770	ナカオサエレンケツベースクミタ	Connecting base assy	1
H 121		MJ60A2920	リニアガイド	Liner motion guide	1
☆ H 122		M94003021	ロッカアナツキホルト M4X12	Socket bolt M4X12	4
H 123		M90971004	SW-PWフライマイナベネジ M3X10	SW-PW pan screw M3X10	1
H 124		MJ60A0484	キンセツスイッチ(ナカオサエ)	Detector	1
☆ H 125		MH10A0602	トリツケカナク	Holder	1
H 126		MJ60A5601	ケンシュツキトリツケイタ	Detector bracket	1
☆ H 127		M90421050	ミカキザガネ 4	Large washer 4	2
☆ H 128		M94001017	セフティソケット M4X10	Safety socket bolt M4X10	2
H 129		M93008021	ロッカアナツキホルト M3X30	Socket bolt M3X30	4
H 130		MJ60A2434	エアシリンダ	Air cylinder	1
H 131		MJ60A0422	エルボユニオン	Connector	2
H 132		MJ60A0982	ワイパートリツケイタ	Wiper setting plate	1
☆ H 133		M90631050	ミカキザガネ 6	Large washer 6	1
H 134		MJ60A0983	ワイパーシャフト	Wiper shaft	1
☆ H 135		M90505065	E型外メワ 5	E-type retaining ring 5	1
☆ H 136		M90806002	ヒラネジ 1/8(44)X6	Flat screw 1/8(44)X6	1
☆ H 137		MH10A0980	ワイパー	Wiper	1
H 138		M98002052	ウレタンワッシャ	Rubber cushion	1
☆ H 139		M90634050	ザガネ	Washer	1
H 140		M91581045	ロッカナット M6	Nut M6	1
H 141		MJ60A0571	ツギテ	Connector	1
☆ H 142		M90910033	ピンネジ 9/64(40)X4	Screw 9/64(40)X4	1
H 143		MJ60A3910	リンク	Wiper connecting rod	1
☆ H 144		M90932015	ヒラネジダツキ 9/64(40)X9	Shoulder bolt 9/64(40)X9	1
☆ H 145		MH10A0981	ワイパーウテ	Wiper adapter	1
☆ H 146		M90909003	マルヒラネジ 9/64(40)X6	Flat screw 9/64(40)X6	2
☆ H 147		M90901045	ナット 9/64(40)	Nut 9/64(40)	1

J かま台機構
HOOK SADDLE MECHANISM

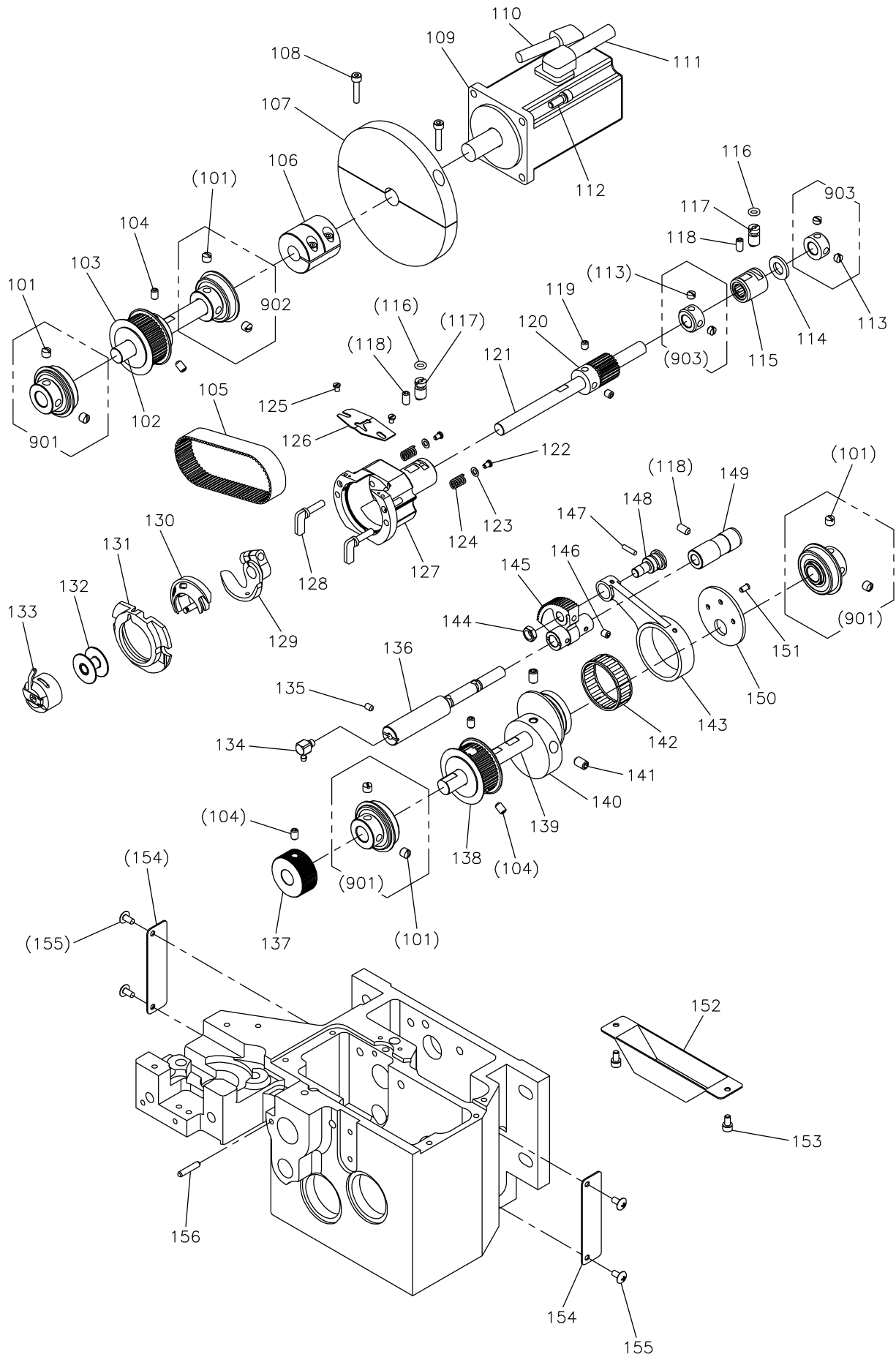

[J]かま台機構

HOOK SADDLE MECHANISM

Fig no.	変更 Mod.	部品コード Parts no.	品名	Description	数量 Amt. Req.
☆ J 101		M91606001	トメネジ 1/4(40)X6	Set screw 1/4(40)X6	8
J 102		MJ61A0454	モータシク	Motor shaft	1
J 103		MJ61A0767	タイミングプーリ	Belt pulley	1
☆ J 104		M95004020	ロッカクアナツキトメネジ M5X8	Set screw M5X8	5
J 105		MJ61A0523	タイミングベルト	Timing belt	1
J 106		MJ60A1364	カップリング	Coupling	1
J 107		MJ61A0383	イナーシャ	Inertia rotor	1
J 108		M94015021	ロッカクアナツキホルト M4X20	Socket bolt M4X20	2
J 109		MJ60A1848	サーボモータ(シタジク)	Servomotor (lower shaft)	1
J 110		MJ60A1508	ケーブル(シタジクモータエンコーダ)	Cable (lower shaft moter encoder)	1
J 111		MJ60B1508	ケーブル(シタジクモータテンケン)	Cable (lower shaft moter power)	1
J 112		M95014017	セフティソケット M5X14	Safety socket bolt M5X14	4
☆ J 113		M91503001	トメネジ 15/64(28)X4.5	Set screw 15/64(28)X4.5	4
J 114		M90903050	ワッシャ	Washer	1
J 115		MJ61A0452	シタジクメタルミタテ	Lower shaft bushing assy	1
☆ J 116		M90500085	リング	O-ring	2
J 117		MJ61A0761	ヘンジンシク	Eccentric shaft	2
J 118		M95001020	ロッカクアナツキトメネジ M5X10	Set screw M5X10	3
☆ J 119		M94001001	トメネジ M5X6	Set screw M5X6	2
J 120		MJ61A0722	ヒラハグルマ	Gear	1
J 121		MJ61A0450	シタジク	Lower shaft	1
☆ J 122		M90802003	マルヒラネジ 1/8(44)X4.5	Flat screw 1/8(44)X4.5	2
☆ J 123		M90306050	ザガネ	Washer	2
☆ J 124		MS01A0572	ツルマキバネ	Spring	2
☆ J 125		M90853002	ヒラネジ 1/8(40)X4	Flat screw 1/8(40)X4	2
☆ J 126		MS01A0329	カマイトアンナイ	Shuttle race thread guide	1
J 127		MJ61A0121	ソトガマクミタテ	Shuttle race assy	1
☆ J 128		MS09A0950	カマオサエツマミ	Shuttle hook clamp	2
☆ J 129		MS01A0611	ドライバ	Hook driver	1
☆ J 130		MA10A0120	ナカガマ	Shuttle hook	1
☆ J 131		MS08A0616	ナカガマオサエ	Shuttle hook retainer	1
☆ J 132		MA10A0123	ボビン	Bobbin	1
☆ J 133		MS17A0125	ボビンケース	Bobbin case	1
J 134		MJ61A1571	カンツキテ	Connector	1
☆ J 135		M91053020	ロッカクアナツキトメネジ M4X6	Set screw M4X6	1
J 136		MJ61A0887	ヨウトウシククミタテ	Rock shaft assy	1
J 137		MJ61A0682	テマワシプーリ	Hand pulley	1
J 138		MJ61A1767	タイミングプーリ	Belt pulley	1
J 139		MJ61A1761	ヘンシンリンシク	Eccentric cam shaft	1
J 140		MJ61A0760	ヘンシンリン	Eccentric cam	1
J 141		M91602020	ロッカクアナツキトメネジ 1/4(40)X10	Set screw 1/4(40)X10	2
J 142		MJ61A0628	ニードルベアリング	Needle bearing	1
J 143		MJ61A0975	ヘンシンロッド	Eccentric rod	1
☆ J 144		M91802045	ナット 9/32(28)	Nut 9/32(28)	1
J 145		MH10A0683	セクタハグルマ	Sector gear	1
☆ J 146		M95002020	ロッカクアナツキトメネジ M5X6	Set screw M5X6	1
J 147		MH10A0740	フェルト	Felt	1
J 148		M91817015	ヒラネジダツキ 9/32(28)	Flat screw 9/32(28)	1
J 149		MH10A0669	ヨウトウシクメタル	Rock shaft bushing	1
J 150		MJ61A2742	ヘンシンリンフタ	Eccentric cam cover	1
J 151		M90902011	マルサラネジ 9/64(40)X7	Countersunk screw 9/64(40)X7	3
J 152		MJ61A3339	イナーシャカバー	Inertia rotor cover	1
☆ J 153		M94002017	セフティソケット M4X8	Safety socket bolt M4X8	2
J 154		MJ61A4339	ソクメンカバー	Cover	2
☆ J 155		M90403036	トラスネジ M4X8	Truss screw M4X8	4
☆ J 156		M90001060	ヘイコウピン φ4X18	Parallel pin φ4X18	1
J 901		MF13E6456	シクウケクミタテ	Ball bearing assy	3
J 902		MJ61E0456	シクウケクミタテ	Ball bearing assy	1
☆ J 903		MJ61E0352	カラークミタテ	Collar assy	2

☆印はPLK-G6030共通部品を示します。

☆ indicates PLK-G6030 common parts.

K 糸切り機構
THREAD TRIMMING MECHANISM

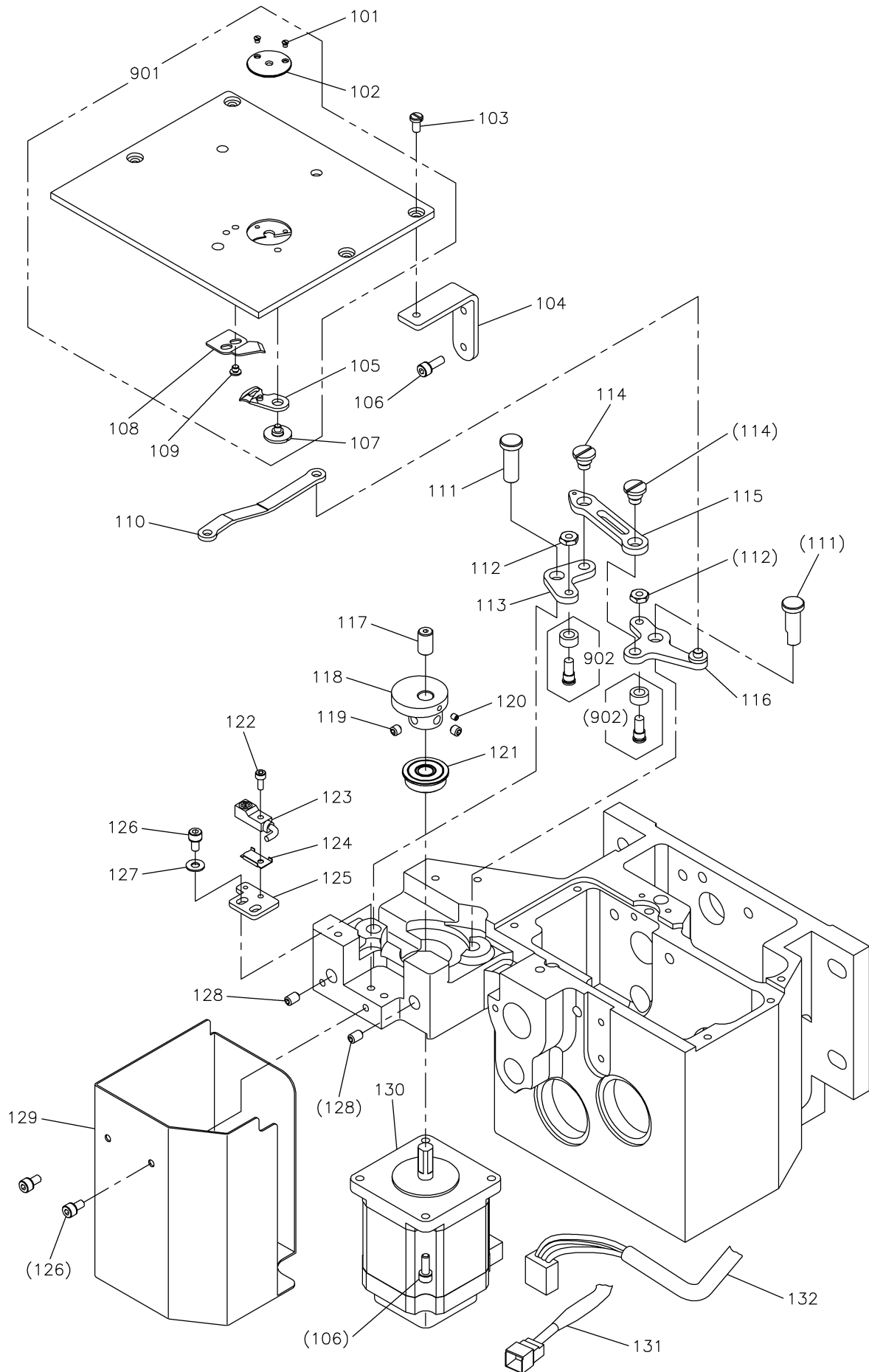

[K]糸切り機構

THREAD TRIMMING MECHANISM

Fig no.	変更 Mod.	部品コード Parts no.	品名	Description	数量 Amt. Req.
☆ K 101		M90605010	サラネジ 3/32(56)X2.8	Countersunk screw 3/32(56)X2.8	2
K 102		MJ61A1101	ハリイタ φ2.2	Needle plate φ2.2	1
☆ K 103		M90990002	ヒラネジ M4X8	Flat screw M4X8	4
K 104		MJ61A1758	トリツケブラケット	Bracket	1
K 105		MH13S0834	イトウメス	Movable knife	1
☆ K 106		M94007017	セフティソケット M4X12	Safety socket bolt M4X12	6
K 107		M90934015	ダンツキネジ 9/64(40)X3.1	Shoulder bolt 9/64(40)X3.1	1
K 108		MH13S0838	コテイメス	Fixed knife	1
☆ K 109		M90906003	マルヒラネジ 9/64(40)X3.2	Flat screw 9/64(40)X3.2	2
K 110		MH13S2910	リンク	Link	1
K 111		M90822060	ピン	Pin	2
K 112		M91201045	ナット 3/16(28)	Nut 3/16 (28)	2
K 113		MJ60A1950	レバー2	Lever 2	1
☆ K 114		M91690015	ヒラネジダンツキ 1/4(40)X4	Flat screw 1/4(40)X4	2
K 115		MJ60A0910	リンク	Link	1
K 116		MJ61A0950	レバー1	Lever 1	1
K 117		M90807063	ロッカアナツキピン	Hexagon socket head pin	1
K 118		MJ61A0350	イトキリカム	Thread trimmer cam	1
☆ K 119		M95004021	ロッカアナツキトメネジ M5X5	Set screw M5X5	2
☆ K 120		M91057020	ロッカアナツキトメネジ M3X4	Set screw M3X4	1
K 121		M91001075	ジクウケ	Ball bearing	1
☆ K 122		M93002021	ロッカアナツキホルト M3X8	Socket bolt M3X8	1
K 123		MJ60A1484	キンセツスイッチ(イトキリ)	Detector	1
☆ K 124		MH10A0602	トリツケカナク	Holder	1
K 125		MJ61A2601	ケンシュツキトリツケイタ	Detector bracket	1
☆ K 126		M94002017	セフティソケット M4X8	Safety socket bolt M4X8	4
☆ K 127		M90421050	ミカキサガネ 4	Washer 4	2
☆ K 128		M95004020	ロッカアナツキトメネジ M5X8	Set screw M5X8	2
K 129		MJ61A5339	モータカバー	Motor cover	1
K 130		MH13A0848	ステッピングモータ	Stepping motor	1
K 131		MJ60A5508	ケーブル(イトキリモータエンコーダ)	Cable (TRIM moter encoder)	1
K 132		MJ60A4508	ケーブル(イトキリモータデンゲン)	Cable (TRIM moter power)	1
K 901		MJ61E0472	スベリイタクミタテ	Slide plate assy	1
K 902		MF01E0411	コロ・コロジククミタテ	Cam follower. Shoulder screw assy	2

L X-Yテーブル機構
X-Y TABLE MECHANISM

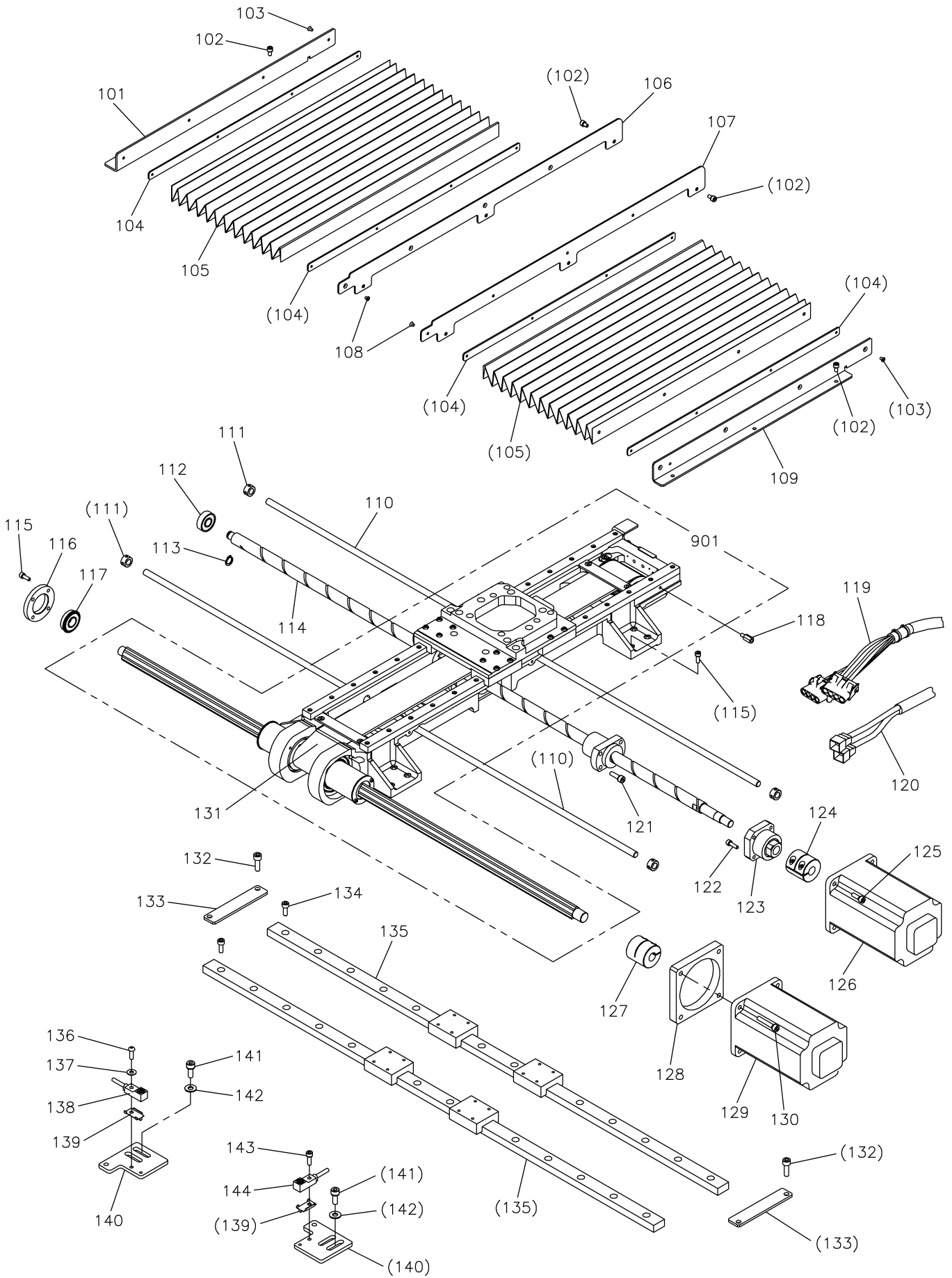

[L]X-Yテーブル機構
X-Y TABLE MECHANISM

Fig no.	変更 Mod.	部品コード Parts no.	品名	Description	数量 Amt. Req.
L	101	MJ60A1228	シャバラトリツケイタ ヒダリ	Shutter adapter (left)	1
☆ L	102	M94002017	セフティソケット M4X8	Safety socket bolt M4X8	12
L	103	M91303010	フライサランジ M3X5	Countersunk screw M3X5	8
L	104	MJ60A0420	シャバラコテイタ	Shutter fixed plate	4
L	105	MJ60A0458	シャバラ	Shutter	2
L	106	MJ60A1359	ガイドイタ ヒダリ	Guide plate (left)	1
L	107	MJ60A0359	ガイドイタ ミキ	Guide plate (right)	1
L	108	M91305010	フライサランジ M3X4	Countersunk screw M3X4	8
L	109	MJ60A0228	シャバラトリツケイタ ミキ	Shutter adapter (right)	1
L	110	MJ60A2454	シャフト	Shaft	2
L	111	MJ60A0352	セットカラー	Set collar	4
L	112	MS02A2456	ジクウケ	Ball bearing	1
L	113	M90516065	Cカ外メワ 10	C-type retaining ring 10	1
L	114	MJ60A0786	ボールネジ	Ball screw	1
☆ L	115	M94007017	セフティソケット M4X12	Safety socket bolt M4X12	20
L	116	MJ60A4780	ベアリングホルダ	Bearing holder	1
☆ L	117	MH40A0456	ジクウケ	Ball bearing	1
L	118	MJ60A5476	スペーサ	Spacer	6
L	119	MJ60B4508	ケーブル(XYモータテンゲン)	Cable (XY moter power)	1
L	120	MJ60B5508	ケーブル(XYモータエンコーダ)	Cable (XY moter encoder)	1
☆ L	121	M95001017	セフティソケット M5X20	Safety socket bolt M5X20	4
☆ L	122	M94019017	セフティソケット M4X14	Safety socket bolt M4X14	4
L	123	MJ60A4426	サポートユニット	Support unit	1
L	124	MJ60A2364	カップリング	Coupling	1
☆ L	125	M95004017	セフティソケット M5X16	Safety socket bolt M5X16	4
L	126	MJ60C1508	ステッピングモータ X	Stepping motor X	1
L	127	MJ60A1364	カップリング	Coupling	1
L	128	MJ60A6476	モータスペーサ	Motor spacer	1
L	129	MJ60C2508	ステッピングモータ Y	Stepping motor Y	1
L	130	M95007017	セフティソケット M5X30	Safety socket bolt M5X30	4
L	131	MJ60A0523	タイミングベルト	Timing belt	1
☆ L	132	M96002017	セフティソケット M6X12	Safety socket bolt M6X12	4
L	133	MJ60A1477	Xストップ	X stopper	2
☆ L	134	M95003021	ロッカアナツキホルト M5X12	Socket bolt M5X12	28
L	135	MJ60A0920	リニアガイド	Liner motion guide	2
☆ L	136	M91606022	ロッカアナツキボタンホルト M3X10	Button bolt M3X10	1
☆ L	137	M90316050	ミカキサガネ 3	Large washer 3	1
L	138	MJ60A2484	キンセツスイッチ(Xジク)	Detector X	1
☆ L	139	MH10A0602	トリツケカナク	Holder	2
L	140	MJ60A6601	ケンシュツキトリツケイタ	Detector bracket	2
☆ L	141	M94001017	セフティソケット M4X10	Safety socket bolt M4X10	4
☆ L	142	M90421050	ミカキサガネ 4	Large washer 4	4
☆ L	143	M93002021	ロッカアナツキホルト M3X8	Socket bolt M3X8	1
L	144	MJ60A3484	キンセツスイッチ(Yジク)	Detector Y	1
L	901	MJ60E0747	外ウフレームクミタテ	Drive frame assy	1

M チャッキング装置
JIG EJECT SYSTEM

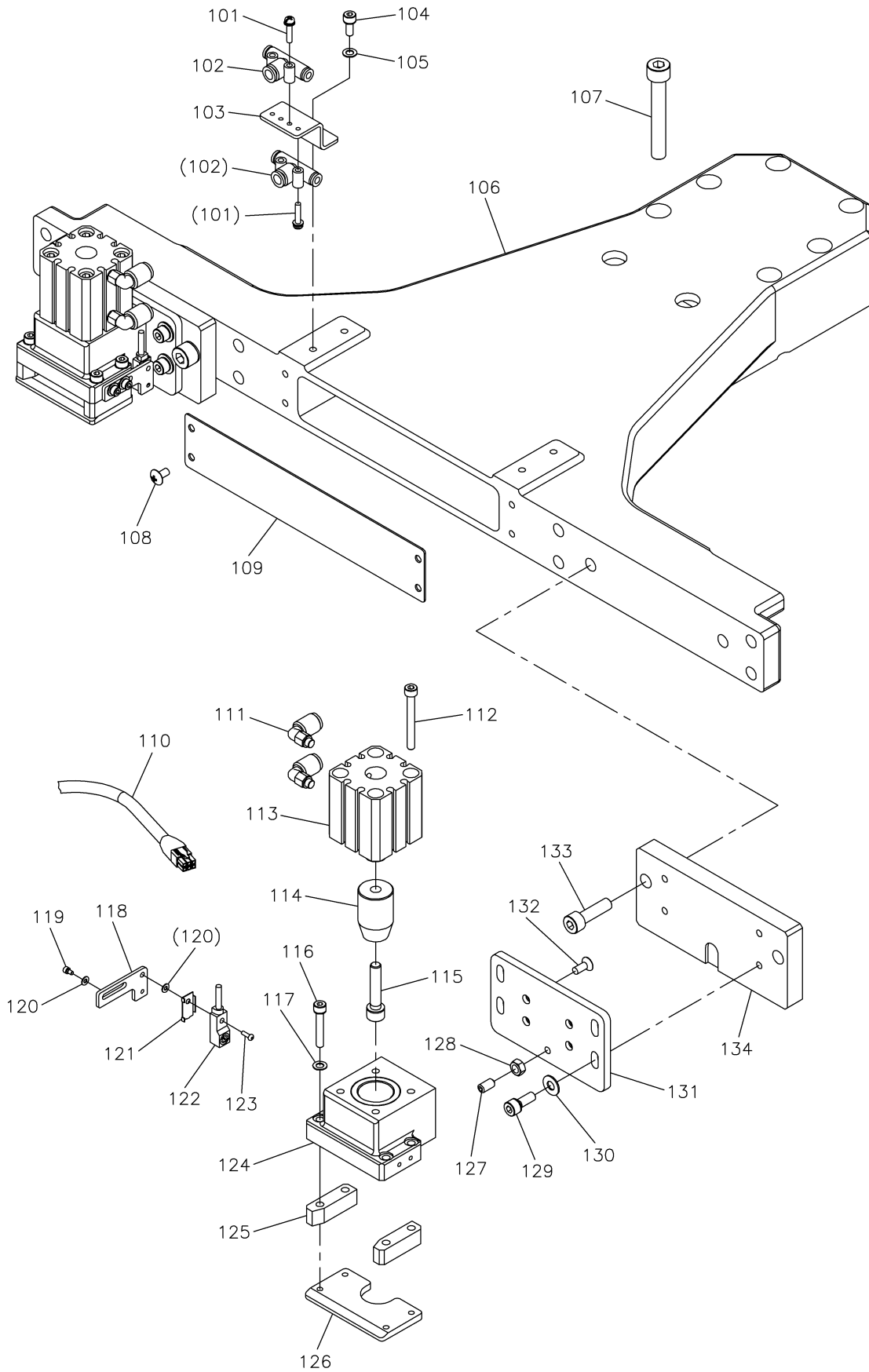

[M]チャッキング装置
JIG EJECT SYSTEM

Fig Mo.	変更 Mod.	部品コード Parts no.	品名	Description	数量 Amt. Req.
☆ M	101	M90864004	SW-PW ^ラ マイナ ^ベ ネジ M3X14	SW-PW pan screw M3X14	4
☆ M	102	MJ60A3571	クダツギ ^テ	T-type quick joint	2
☆ M	103	MJ60A1420	ツギ ^テ コテイ ^イ タ	Air fitting bracket	1
☆ M	104	M94007017	セフ ^テ イソ ^ケ ット M4X12	Safety socket bolt M4X12	1
☆ M	105	M90421050	ミカ ^キ サ ^ガ ネ 4	Large washer 4	1
M	106	MJ60A5747	オサ ^エ フ ^レ ーム	Clamp frame	1
M	107	M98003021	ロツ ^カ ク ^ア ナツ ^キ ホ ^ル ト M8X55	Socket bolt M8X55	6
☆ M	108	M90403036	トラス ^ネ ジ M4X8	Truss screw M4X8	4
M	109	MJ60A3742	フ ^タ	Cover	1
M	110	MJ60B2508	ケー ^ブ ル(チャ ^ク キング ^セ ンサ)	Cable (jig eject sensor)	1
M	111	MB61A1571	エル ^ホ ユ ^ニ オン	Connector	4
☆ M	112	M95035021	ロツ ^カ ク ^ア ナツ ^キ ホ ^ル ト M5X45	Socket bolt M5X45	8
M	113	MJ60A3434	ウス ^カ タ ^シ リン ^ダ	Air cylinder	2
M	114	MJ60A0755	テー ^パ ーフ ^ッ シャ	Taper pusher	2
M	115	M96007017	セフ ^テ イソ ^ケ ット M6X30	Safety socket bolt M6X30	2
M	116	M94025017	セフ ^テ イソ ^ケ ット M4X25	Safety socket bolt M4X25	8
☆ M	117	M90422050	コ ^ザ ガ ^ネ 4	Small washer 4	8
M	118	MJ60A4601	セン ^サ トリ ^ツ ケ ^イ タ	Detector bracket	2
M	119	M94012017	セフ ^テ イソ ^ケ ット M3X8	Safety socket bolt M3X8	4
☆ M	120	M90316050	ミカ ^キ サ ^ガ ネ 3	Large washer 3	6
☆ M	121	MH10A0602	トリ ^ツ ケ ^カ ナ ^ガ	Holder	2
M	122	MJ60A4484	キン ^セ ツ ^ス イ ^ッ チ(チャ ^ク キング)	Detector	2
☆ M	123	M91606022	ロツ ^カ ク ^ア ナツ ^キ ホ ^ル ト ^タ ン ^ホ ル ^ト M3X10	Button bolt M3X10	2
M	124	MJ60E1747	ジ ^グ フ ^レ ーム ^ク ミ ^タ テ	Jig eject flame assy	2
M	125	MJ60A2359	サイ ^ト ガ ^イ ト	Side guide	4
M	126	MJ60A3359	アン ^ダ ー ^ガ イ ^ト	Under guide	2
M	127	M95001020	ロツ ^カ ク ^ア ナツ ^キ ト ^メ ネ ^ジ M5X10	Set screw M5X10	2
☆ M	128	M91382045	ナ ^ツ M5	Nut M5	2
☆ M	129	M95014017	セフ ^テ イソ ^ケ ット M5X14	Safety socket bolt M5X14	8
☆ M	130	M90511050	ミカ ^キ サ ^ガ ネ 5	Large washer 5	8
M	131	MJ60A4770	ジ ^グ ベ ^ー ス	Jig eject base	2
M	132	M91500010	Pサ ^ラ ネ ^ジ M5X12	Countersunk screw M5X12	8
☆ M	133	M98001017	セフ ^テ イソ ^ケ ット M8X25	Safety socket bolt M8X25	4
M	134	MJ60A0476	ス ^ペ ー ^サ	Spacer	2

N 配線・配管関係
CABLE COMPONENT & PNEUMATIC CONTROL UNIT

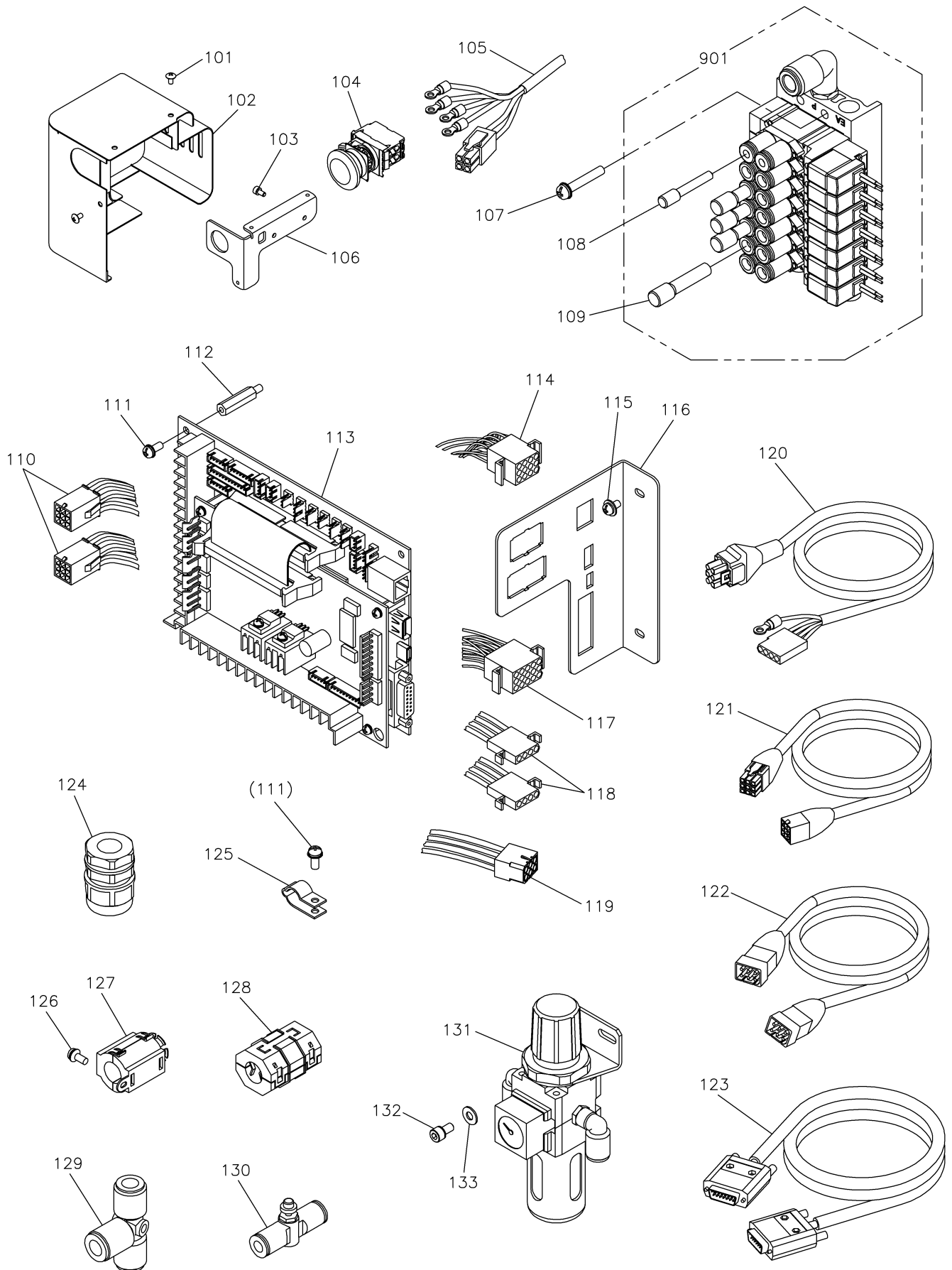

[N]配線・配管関係

CABLE COMPONENT & PNEUMATIC CONTROL UNIT

Fig no.	変更 Mod.	部品コード Parts no.	品名	Description	数量 Amt. Req.
☆ N 101		M90403036	トラスネジ M4X8	Truss screw M4X8	3
N 102		MJ60B5339	トウフカバー	Head cover	1
☆ N 103		M94002017	セフティソケット M4X8	Safety socket bolt M4X8	2
N 104		MJ60A5484	トチュウテイスイツチ	Stop switch	1
N 105		MJ60B0508	ケーブル(トチュウテイシ/PFセンサ)	Cable (stop switch/PF sensor)	1
N 106		MJ60A9601	スイッチトリツケイタ	Stop switch bracket	1
N 107		M91066004	SW-PWプラマイナヘネジ M4X25	SW-PW pan screw M4X25	4
N 108		MA30A0757	プラグ	Plug	1
N 109		MB62A0757	プラグ	Plug	4
N 110		MJ60B9508	ケーブル(フカンクモータエンコーダ)	Cable (DT/TRIM moter encoder)	1
☆ N 111		K14S90203410	SW-PW Pナヘネジ M4X10	SW-PW pan screw M4X10	11
N 112		MJ60A3476	スペーサボルト	Spacer bolt	4
N 113		M800J2MIF	MIFキバン PLK-J2-MIF	Print circuit board PLK-J2-MIF	1
N 114		MJ60B6508	ケーブル(MIFニューリヨク)	Cable (MIF input)	1
☆ N 115		M91071004	SW-MWプラマイナヘネジ M4X8	SW-MW pan screw M4X8	2
N 116		MJ60A3601	MIFコネクタトリツケイタ	MIF connector bracket	1
N 117		MJ60B7508	ケーブル(MIFシュツリヨク)	Cable (MIF output)	1
N 118		MJ60B8508	ケーブル(フカンクモータデンゲン)	Cable (DT/TRIM moter power)	1
N 119		MJ60C0508	ケーブル(MIFデンゲン)	Cable (MIF power)	1
N 120		MJ60A2508	ケーブル(PFモータデンゲン)	Cable (PF moter power)	1
N 121		MJ60A3508	ケーブル(PFモータエンコーダ)	Cable (PF moter encoder)	1
N 122		MJ60B3508	ケーブル(MIFキバンデンゲン)	Cable (MIF power)	1
☆ N 123		M97320099	ケーブル(MIFキバンシンゴウ)	Cable (MIF signal pulse)	1
N 124		MB60A5780	ケーブルグラント	Cable gland	3
☆ N 125		MB60A0620	ナイロンクリップ FG	Nylon clip FG	5
☆ N 126		M91056004	SW-PWプラマイナヘネジ M4X10	SW-PW pan screw M4X10	4
☆ N 127		K14M19400102	フェライトコア	Ferritic core	5
N 128		MJ60A0413	フェライトコア	Ferritic core	1
N 129		MJ60A1571	チース	T-shape connector	1
N 130		MH60T0497	スピードコントローラ	Speed controller	2
☆ N 131		ME40A0963	フィルタレギュレータ	Filter regulator	1
☆ N 132		M95003017	セフティソケット M5X8	Safety socket bolt M5X8	2
☆ N 133		M90511050	ミカキサガネ 5	Large washer 5	2
N 901		MJ60E0599	デンジベンクミタテ	Solenoid valve complete	1

P 給油機構
OIL LUBRICATION MECHANISM

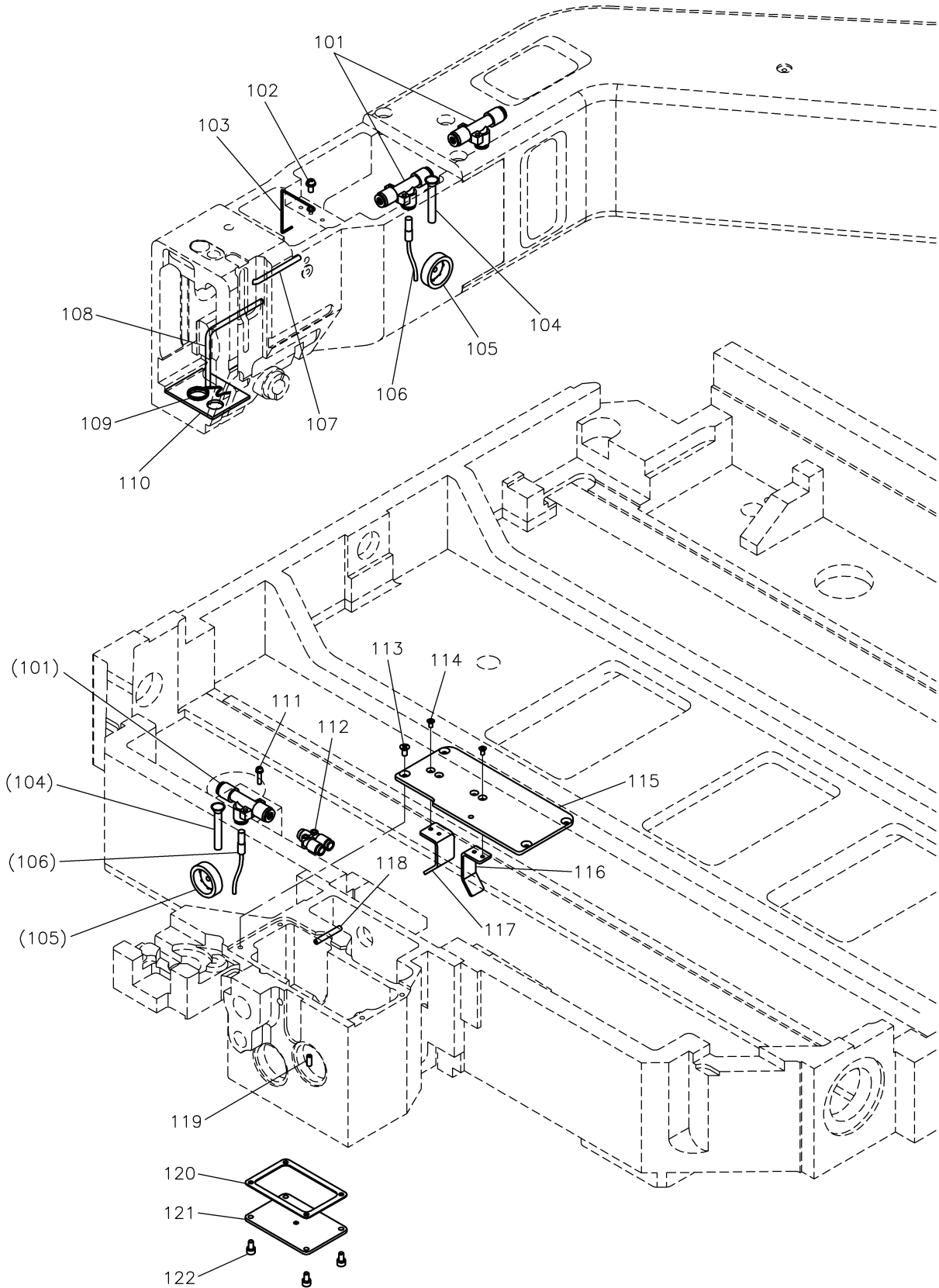

[P]給油機構

OIL LUBRICATION MECHANISM

Fig no.	変更 Mod.	部品コード Parts no.	品 名	Description	数量 Amt. Req.
P 101		MJ60A2571	シクウエジェクタ	Vacuum ejector	3
☆ P 102		M91056004	SW-PWプラマイナベネジ M4X10	SW-PW pan screw M4X10	1
P 103		ME20A2780	ホルダ	Holder	1
☆ P 104		MA20A6688	パイプ 43L	Pipe 43L	2
☆ P 105		MN10A0135	アブラマト	Oil gauge	2
P 106		MJ60E1688	キュウユパイプクミタテ	Filler pipe assy	1
P 107		MJ60A0688	オイルパイプ A	Oil pipe A	1
P 108		MJ60A1688	オイルパイプ B	Oil pipe B	1
☆ P 109		MF00A2780	ホルダ	Holder	1
P 110		MJ60A0740	フェルト	Felt	1
☆ P 111		M90864004	SW-PWプラマイナベネジ M3X14	SW-PW pan screw M3X14	2
P 112		MJ61A0422	ユニオンY	Y-type quick joint	3
☆ P 113		M90449037	Pサラネジ M4X8	Countersunk screw M4X8	6
☆ P 114		M91304010	Pサラネジ M3X6	Countersunk screw M3X6	2
P 115		MJ61A6339	ギヤカバー	Gear cover	1
P 116		MJ61A0426	グリスサポータA	Grease supporter A	1
P 117		MJ61A1426	グリスサポータB	Grease supporter B	1
P 118		MJ61A0688	オイルパイプC	Oil pipe C	1
P 119		MJ61A1688	オイルパイプD	Oil pipe D	1
P 120		MJ61A0691	ガスケット	Gasket	1
P 121		MJ61A0516	ソコフタクミタテ	Bottom cover assy	1
☆ P 122		M94002017	セフティソケット M4X8	Safety socket bolt M4X8	4

Q テーブル関係
TABLE & STAND

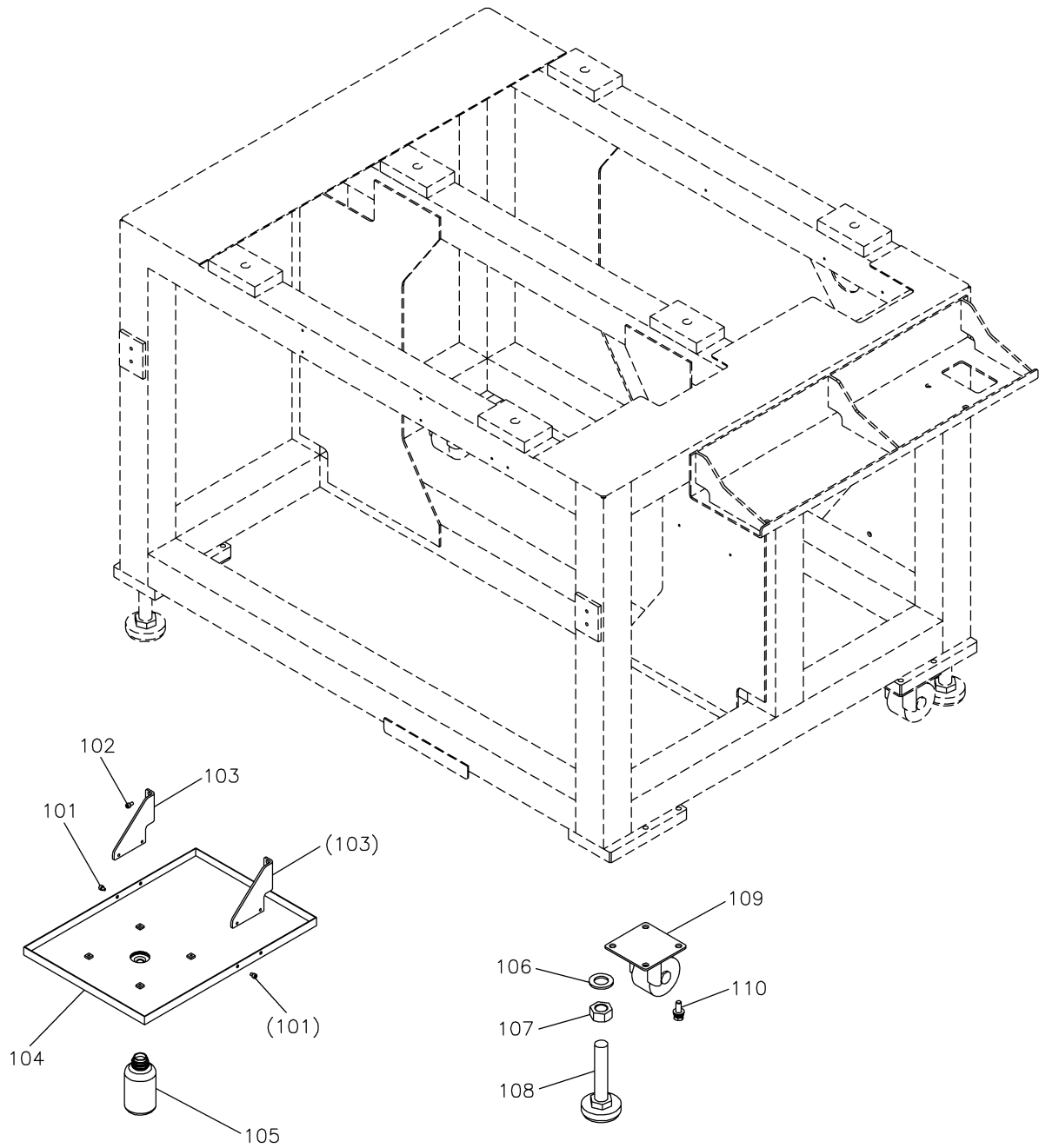

[Q]テーブル関係
TABLE & STAND

Fig no.	変更 Mod.	部品コード Parts no.	品 名	Description	数量 Amt. Req.
☆ Q 101		M94008017	セフティソケット M4X6	Safety socket bolt M4X6	4
☆ Q 102		M94002017	セフティソケット M4X8	Safety socket bolt M4X8	4
Q 103		MJ60A5426	オイルパンササエ	Oil pan bracket	2
Q 104		MJ60A0131	アブラウケクミタテ	Oil pan assy	1
☆ Q 105		MF20A0130	アブラビン	Oil bottle	1
☆ Q 106		M92002050	サガネ 20	Washer 20	4
☆ Q 107		M95021045	ナット M20	Nut M20	4
☆ Q 108		MA35A0166	アシヤスタフット	Ajustor foot	4
☆ Q 109		ME40A0368	キャスター	Castor	4
☆ Q 110		M92058022	SW-PWロッカケホルト M8X25	SW-PW hexagon bolt M8X25	16

R 付属品
ACCESSORIES

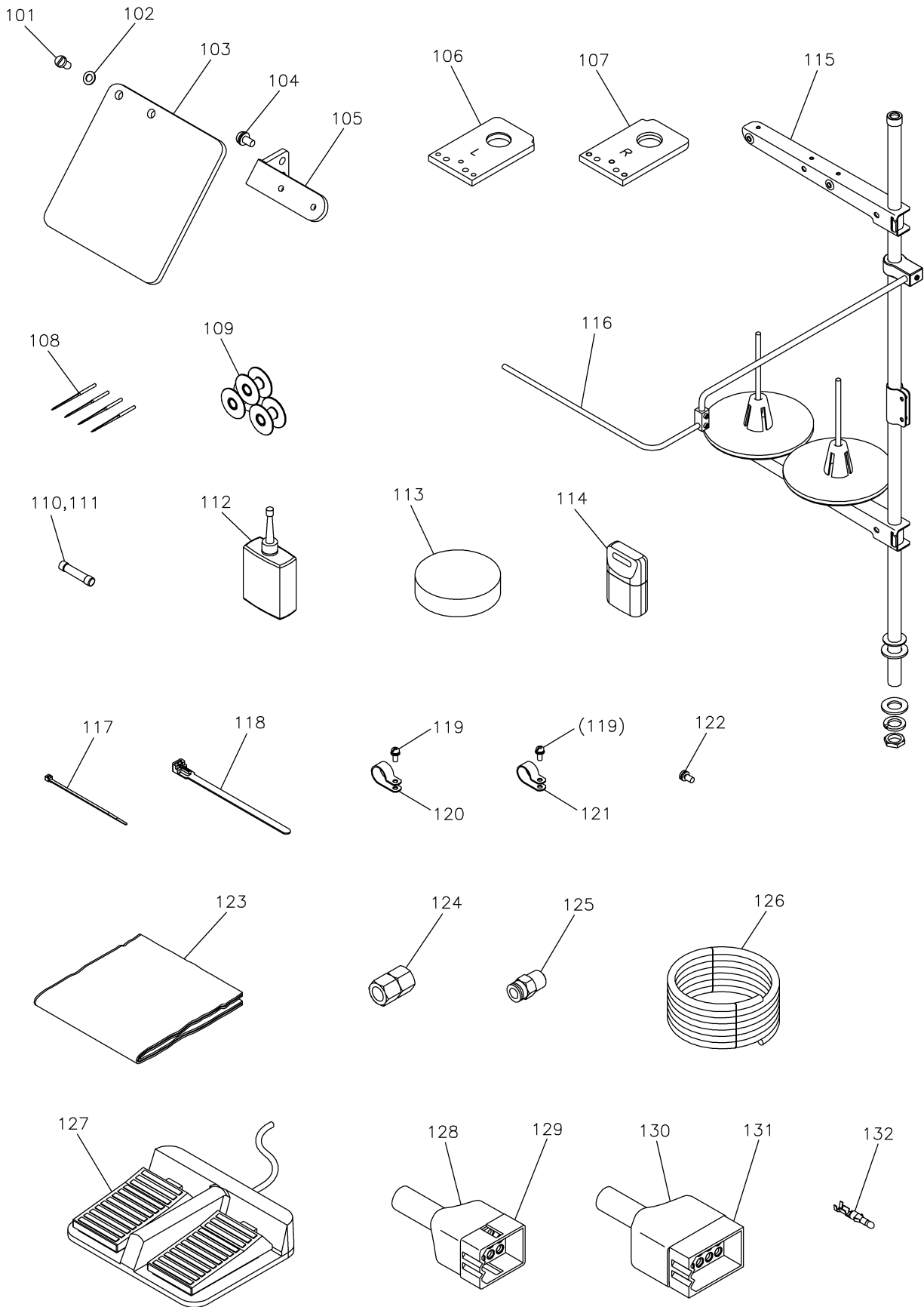

[R] 付属品
ACCESSORIES

Fig no.	変更 Mod.	部品コード Parts no.	品名	Description	数量 Amt. Req.
☆ R 101		M90806002	ヒラネジ 1/8(44)X6	Flat screw 1/8(44)X6	2
☆ R 102		M90317050	コザガネ 3	Small washer 3	2
☆ R 103		MH10A0160	アイガード	Eye guard	1
☆ R 104		M90859004	SW-PWプラマイナヘネジ M3X6	SW-PW pan screw M3X6	2
R 105		MJ60B0601	アイガードトリツケイタ	Eye guard bracket	1
R 106		MJ60A2780	ホルダ(L)	Jig eject holder (left)	1
R 107		MJ60A3780	ホルダ(R)	Jig eject holder (right)	1
☆ R 108		MS02A0128	ミシンハリ DPX17#18	Needle DPX17#18	4
☆ R 109		MA10A0123	ホビン	Bobbin	3
☆ R 110		K14M46000158	ヒューズ 2.5A	Fuse 2.5A	1
☆ R 111		K14M46000159	ヒューズ 20A	Fuse 20A	1
☆ R 112		MF10A0149	アブラサシ	Oiler	1
R 113		MJ60A1419	ホウシゴム	Rubber cushion	4
R 114		MJ60E0991	USBメモリ	USB memory	1
☆ R 115		MH10E0193	イトタテダセット	Cotton stand assy	1
R 116		ME35E0180	イトアンナイクミタテ	Thread guide assy	1
☆ R 117		MF06A1620	ケツクバンド L=100	Cable tie L=100	1
☆ R 118		MB60A0201	ケツクバンド L=140	Cable tie L=140	3
☆ R 119		M91056004	SW-PWプラマイナヘネジ M4X10	SW-PW pan screw M4X10	2
☆ R 120		MB60A2620	ナイロンクリップ 10N	Nylon clip 10N	1
☆ R 121		MB60A1620	ナイロンクリップ 8N	Nylon clip 8N	1
☆ R 122		K14S90203410	SW-PW Pナヘネジ M4X10	Screw M4X10	1
☆ R 123		MA20A0734	ビニールカバー	Polyethylene cover	1
☆ R 124		M91010089	ロッカクソケット	Socket	1
☆ R 125		MA30A0571	ワンタッチツギテ	Quickjoint	1
☆ R 126		MS06A0567	ウレタンチューブ	Air tube	1
☆ R 127		M860A0FSW	フットスイッチ	Foot switch	1
☆ R 128		K14M96821809	ナイロンキャップ 12P	Nylon cap 12P	1
☆ R 129		K14M94319012	コネクタ 12P	Connector 12P	1
☆ R 130		K14M96822602	ナイロンキャップ 15P	Nylon cap 15P	1
☆ R 131		K14M94319015	コネクタ 15P	Connector 15P	1
☆ R 132		K14M77014710	ターミナル	Terminal	30

S オプションパーツ
OPTION PARTS

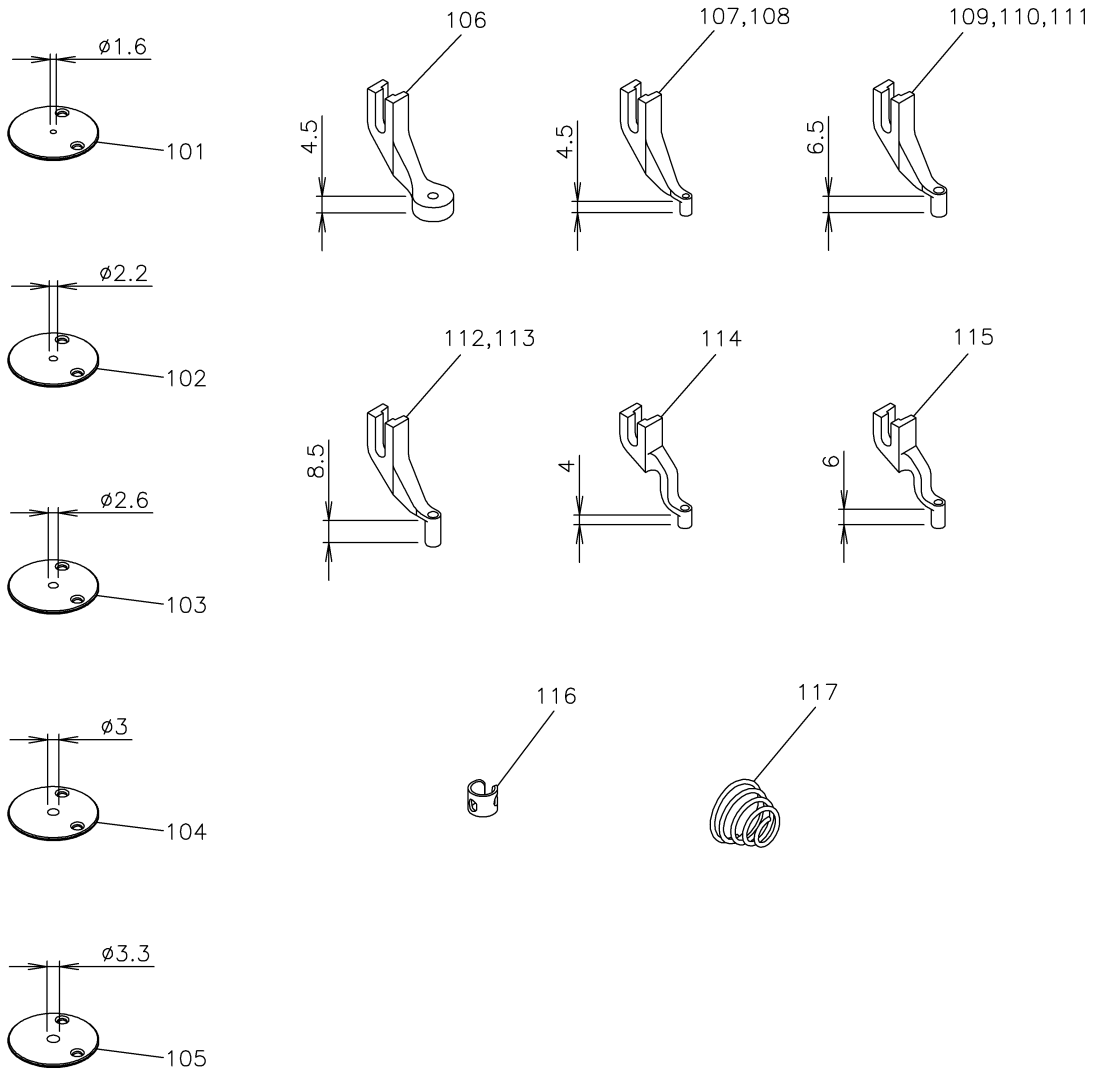

[S]オプションパーツ
OPTION PARTS

Fig no.	変更 Mod.	部品コード Parts no.	品 名	Description	数量 Amt. Req.
S 101		MJ61A0101	ハリタ φ1.6	Needle plate φ1.6	1
S 102		MJ61A1101	ハリタ φ2.2 (ヒョウジユン)	Needle plate φ2.2 (standard)	1
S 103		MJ61A2101	ハリタ φ2.6	Needle plate φ2.6	1
S 104		MJ61A3101	ハリタ φ3	Needle plate φ3	1
S 105		MJ61A4101	ハリタ φ3.3	Needle plate φ3.3	1
☆ S 106		MV35A0106	サラオサエ φ3	Presser foot φ3	1
☆ S 107		MV30A0256	ナカオサエ φ3 (ヒョウジユン)	Presser foot φ3 (standard)	1
☆ S 108		MV30A1256	ナカオサエ φ2	Presser foot φ2	1
☆ S 109		MB10M0256	ナカオサエ φ3.3	Presser foot φ3.3	1
☆ S 110		MS03A0256	ナカオサエ φ3	Presser foot φ3	1
☆ S 111		MS03A1256	ナカオサエ φ2	Presser foot φ2	1
☆ S 112		MA35A0256	ナカオサエ φ3	Presser foot φ3	1
☆ S 113		MA35A1256	ナカオサエ φ2	Presser foot φ2	1
☆ S 114		MA21A0256	ナカオサエ φ2.5	Presser foot φ2.5	1
☆ S 115		MA21A1256	ナカオサエ φ2.5	Presser foot φ2.5	1
☆ S 116		MG42A0181	イトアンナイ(アツモ/ヨウ)	Thread guide (for heavy)	1
S 117		MJ60A1245	エンスイハネ φ1.6	Thread tension spring φ1.6	1

索引
INDEX-1

部品コード Parts No.	ページ Page	Fig No.	部品コード Parts No.	ページ Page	Fig No.	部品コード Parts No.	ページ Page	Fig No.	部品コード Parts No.	ページ Page	Fig No.
K14M19400102	*** P25	*** N 127	M90631050	*** P15	*** H 133	M91201045	*** P19	*** K 112	M94003021	*** P15	*** H 122
K14M46000158	*** P31	*** R 110	M90634050	*** P15	*** H 139	M91303010	*** P21	*** L 103	M94007017	*** P13	*** G 104
K14M46000159	*** P31	*** R 111	M90802003	*** P17	*** J 122	M91304010	*** P5	*** C 103	↑	*** P15	*** H 102
K14M77014710	*** P31	*** R 132	M90806002	*** P15	*** H 136	↑	*** P27	*** P 114	↑	*** P19	*** K 106
K14M94319012	*** P31	*** R 129	↑	*** P31	*** R 101	M91305010	*** P21	*** L 108	↑	*** P21	*** L 115
K14M94319015	*** P31	*** R 131	M90807063	*** P19	*** K 117	M91382045	*** P23	*** M 128	↑	*** P23	*** M 104
K14M96821809	*** P31	*** R 128	M90815002	*** P11	*** F 136	M91384045	*** P7	*** D 106	M94008017	*** P3	*** B 107
K14M96822602	*** P31	*** R 130	M90822060	*** P19	*** K 111	M91400010	*** P13	*** G 105	↑	*** P7	*** D 109
K14S90203410	*** P3	*** B 128	M90825050	*** P3	*** B 109	M91500010	*** P23	*** M 132	↑	*** P29	*** Q 101
↑	*** P25	*** N 111	M90853002	*** P17	*** J 125	M91503001	*** P17	*** J 113	M94012017	*** P15	*** H 116
↑	*** P31	*** R 122	M90858004	*** P9	*** E 105	M91506001	*** P15	*** H 108	↑	*** P23	*** M 119
M800J2MIF	*** P25	*** N 113	M90859004	*** P9	*** E 118	M91581045	*** P15	*** H 140	M94015021	*** P17	*** J 108
M860A0FSW	*** P31	*** R 127	↑	*** P31	*** R 104	M91602001	*** P11	*** F 125	M94019017	*** P21	*** L 122
M90001060	*** P17	*** J 156	M90864004	*** P23	*** M 101	M91602020	*** P17	*** J 141	M94025017	*** P23	*** M 116
M90302036	*** P7	*** D 129	↑	*** P27	*** P 111	M91603046	*** P9	*** E 147	M94036021	*** P13	*** G 134
M90306050	*** P17	*** J 123	M90883080	*** P9	*** E 131	M91606001	*** P11	*** F 124	M95001017	*** P21	*** L 121
M90316050	*** P21	*** L 137	M90901045	*** P15	*** H 147	↑	*** P17	*** J 101	M95001020	*** P17	*** J 118
↑	*** P23	*** M 120	M90902011	*** P17	*** J 151	M91606022	*** P21	*** L 136	↑	*** P23	*** M 127
M90317050	*** P31	*** R 102	M90902015	*** P13	*** G 121	↑	*** P23	*** M 123	M95002017	*** P5	*** C 111
M90403036	*** P3	*** B 106	M90903050	*** P17	*** J 114	M91650020	*** P11	*** F 121	M95002020	*** P11	*** F 110
↑	*** P9	*** E 133	M90906003	*** P19	*** K 109	M91690015	*** P19	*** K 114	↑	*** P17	*** J 146
↑	*** P17	*** J 155	M90907010	*** P9	*** E 144	M91802006	*** P11	*** F 123	M95003017	*** P7	*** D 138
↑	*** P23	*** M 108	M90909003	*** P15	*** H 146	M91802045	*** P17	*** J 144	↑	*** P25	*** N 132
↑	*** P25	*** N 101	M90910033	*** P15	*** H 142	M91817015	*** P17	*** J 148	M95003021	*** P3	*** B 124
M90406064	*** P11	*** F 103	M90920002	*** P9	*** E 142	M91910080	*** P9	*** E 130	↑	*** P9	*** E 129
M90421050	*** P3	*** B 145	M90922002	*** P15	*** H 114	M92000010	*** P9	*** E 106	↑	*** P21	*** L 134
↑	*** P5	*** C 121	M90932015	*** P15	*** H 144	M92001021	*** P13	*** G 133	M95004017	*** P21	*** L 125
↑	*** P7	*** D 122	M90934015	*** P19	*** K 107	M92002050	*** P29	*** Q 106	M95004020	*** P11	*** F 107
↑	*** P13	*** G 139	M90971004	*** P15	*** H 123	M92004020	*** P9	*** E 112	↑	*** P13	*** G 107
↑	*** P15	*** H 127	M90990002	*** P5	*** C 101	M92058022	*** P29	*** Q 110	↑	*** P17	*** J 104
↑	*** P19	*** K 127	↑	*** P11	*** F 127	M92453047	*** P13	*** G 118	↑	*** P19	*** K 128
↑	*** P21	*** L 142	↑	*** P19	*** K 103	M93000022	*** P9	*** E 116	M95004021	*** P19	*** K 119
↑	*** P23	*** M 105	M90991002	*** P3	*** B 140	M93002021	*** P15	*** H 117	M95005017	*** P5	*** C 106
M90422050	*** P3	*** B 113	M91001075	*** P19	*** K 121	↑	*** P19	*** K 122	↑	*** P7	*** D 116
↑	*** P23	*** M 117	M91007045	*** P3	*** B 114	↑	*** P21	*** L 143	M95007017	*** P21	*** L 130
M90434060	*** P13	*** G 138	M91010089	*** P31	*** R 124	M93003021	*** P13	*** G 109	M95009021	*** P3	*** B 132
M90449037	*** P3	*** B 137	M91011004	*** P9	*** E 135	↑	*** P15	*** H 119	M95014017	*** P17	*** J 112
↑	*** P7	*** D 101	↑	*** P13	*** G 124	M93008021	*** P15	*** H 129	↑	*** P23	*** M 129
↑	*** P27	*** P 113	M91051020	*** P9	*** E 136	M93022021	*** P13	*** G 116	M95021045	*** P29	*** Q 107
M90500085	*** P11	*** F 131	M91053020	*** P9	*** E 128	M94001001	*** P15	*** H 103	M95025045	*** P3	*** B 123
↑	*** P17	*** J 116	↑	*** P11	*** F 112	↑	*** P17	*** J 119	M95035021	*** P23	*** M 112
M90503036	*** P3	*** B 102	↑	*** P13	*** G 115	M94001017	*** P5	*** C 110	M95053021	*** P3	*** B 115
M90505065	*** P15	*** H 135	↑	*** P17	*** J 135	↑	*** P15	*** H 128	M96001017	*** P11	*** F 117
M90511050	*** P5	*** C 107	M91056004	*** P25	*** N 126	↑	*** P21	*** L 141	M96002017	*** P21	*** L 132
↑	*** P7	*** D 117	↑	*** P27	*** P 102	M94001021	*** P7	*** D 114	M96007017	*** P23	*** M 115
↑	*** P23	*** M 130	↑	*** P31	*** R 119	M94002017	*** P3	*** B 146	M96008017	*** P7	*** D 130
↑	*** P25	*** N 133	M91057020	*** P19	*** K 120	↑	*** P5	*** C 122	M97320099	*** P25	*** N 123
M90512065	*** P13	*** G 137	M91066004	*** P25	*** N 107	↑	*** P7	*** D 123	M98001017	*** P23	*** M 133
M90516065	*** P21	*** L 113	M91071004	*** P3	*** B 120	↑	*** P17	*** J 153	M98002031	*** P3	*** B 108
M90522037	*** P7	*** D 102	↑	*** P25	*** N 115	↑	*** P19	*** K 126	M98002052	*** P15	*** H 138
M90522050	*** P7	*** D 105	M91084004	*** P9	*** E 138	↑	*** P21	*** L 102	M98003021	*** P23	*** M 107
M90600085	*** P15	*** H 110	M91119002	*** P11	*** F 101	↑	*** P25	*** N 103	M98004017	*** P9	*** E 127
M90602003	*** P9	*** E 146	M91127015	*** P7	*** D 110	↑	*** P27	*** P 122	MA10A0120	*** P17	*** J 130
M90605010	*** P9	*** E 101	M91150003	*** P9	*** E 122	↑	*** P29	*** Q 102	MA10A0123	*** P17	*** J 132
↑	*** P19	*** K 101	M91182080	*** P3	*** B 141	M94003017	*** P13	*** G 119	MA10A0123	*** P31	*** R 109

索引
INDEX-2

部品コード Parts No.	ページ Page	Fig No.	部品コード Parts No.	ページ Page	Fig No.	部品コード Parts No.	ページ Page	Fig No.	部品コード Parts No.	ページ Page	Fig No.
MA20A0361	*** P5	*** C 108	MH10A0669	*** P17	*** J 149	MJ60A0482	*** P13	*** G 126	MJ60A1599	*** P7	*** D 125
MA20A0734	*** P31	*** R 123	MH10A0683	*** P17	*** J 145	MJ60A0484	*** P15	*** H 124	MJ60A1601	*** P3	*** B 117
MA20A6688	*** P27	*** P 104	MH10A0722	*** P11	*** F 109	MJ60A0500	*** P9	*** E 132	MJ60A1688	*** P27	*** P 108
MA21A0256	*** P33	*** S 114	MH10A0740	*** P17	*** J 147	MJ60A0508	*** P11	*** F 116	MJ60A1722	*** P13	*** G 108
MA21A1256	*** P33	*** S 115	MH10A0833	*** P11	*** F 106	MJ60A0523	*** P21	*** L 131	MJ60A1739	*** P7	*** D 118
MA30A0571	*** P31	*** R 125	MH10A0980	*** P15	*** H 137	MJ60A0556	*** P13	*** G 129	MJ60A1742	*** P3	*** B 127
MA30A0757	*** P25	*** N 108	MH10A0981	*** P15	*** H 145	MJ60A0567	*** P3	*** B 118	MJ60A1751	*** P13	*** G 111
MA35A0166	*** P29	*** Q 108	MH10A1722	*** P11	*** F 118	MJ60A0571	*** P15	*** H 141	MJ60A1758	*** P5	*** C 116
MA35A0256	*** P33	*** S 112	MH10A2701	*** P13	*** G 140	MJ60A0573	*** P13	*** G 132	MJ60A1770	*** P7	*** D 136
MA35A1256	*** P33	*** S 113	MH10A3181	*** P9	*** E 149	MJ60A0595	*** P7	*** D 127	MJ60A1780	*** P3	*** B 119
MB10M0256	*** P33	*** S 109	MH10E0193	*** P31	*** R 115	MJ60A0600	*** P9	*** E 123	MJ60A1799	*** P5	*** C 127
MB60A0201	*** P31	*** R 118	MH10E0456	*** P11	*** F 902	MJ60A0601	*** P3	*** B 122	MJ60A1848	*** P17	*** J 109
MB60A0620	*** P25	*** N 125	MH10E0550	*** P9	*** E 902	MJ60A0602	*** P7	*** D 131	MJ60A1910	*** P7	*** D 113
MB60A1620	*** P31	*** R 121	MH13A0848	*** P13	*** G 103	MJ60A0625	*** P13	*** G 135	MJ60A1950	*** P19	*** K 113
MB60A2620	*** P31	*** R 120	↑	*** P19	*** K 130	MJ60A0664	*** P11	*** F 132	MJ60A2339	*** P3	*** B 103
MB60A5780	*** P25	*** N 124	MH13S0834	*** P19	*** K 105	MJ60A0682	*** P11	*** F 102	MJ60A2359	*** P23	*** M 125
MB61A1571	*** P7	*** D 120	MH13S0838	*** P19	*** K 108	MJ60A0688	*** P27	*** P 107	MJ60A2364	*** P21	*** L 124
↑	*** P23	*** M 111	MH13S2910	*** P19	*** K 110	MJ60A0691	*** P3	*** B 143	MJ60A2426	*** P5	*** C 124
MB62A0757	*** P25	*** N 109	MH25A1476	*** P9	*** E 126	MJ60A0696	*** P3	*** B 129	MJ60A2429	*** P5	*** C 117
MB62A4601	*** P3	*** B 144	MH25E0210	*** P9	*** E 124	MJ60A0721	*** P11	*** F 122	MJ60A2434	*** P15	*** H 130
↑	*** P5	*** C 120	MH40A0456	*** P21	*** L 117	MJ60A0722	*** P13	*** G 114	MJ60A2454	*** P21	*** L 110
ME20A2780	*** P27	*** P 103	MH40A0620	*** P7	*** D 126	MJ60A0739	*** P7	*** D 111	MJ60A2476	*** P3	*** B 130
ME35E0180	*** P31	*** R 116	MH40A0809	*** P7	*** D 137	MJ60A0740	*** P27	*** P 110	MJ60A2484	*** P21	*** L 138
ME40A0368	*** P29	*** Q 109	MH40A0958	*** P7	*** D 134	MJ60A0751	*** P15	*** H 106	MJ60A2508	*** P25	*** N 120
ME40A0758	*** P5	*** C 119	MH40A1620	*** P5	*** C 118	MJ60A0755	*** P23	*** M 114	MJ60A2571	*** P27	*** P 101
ME40A0963	*** P25	*** N 131	MH40A1958	*** P7	*** D 132	MJ60A0770	*** P13	*** G 117	MJ60A2601	*** P3	*** B 110
ME60A0361	*** P5	*** C 113	MH40A2601	*** P7	*** D 128	MJ60A0786	*** P21	*** L 114	MJ60A2722	*** P15	*** H 104
ME60A1361	*** P5	*** C 125	MH40A2958	*** P7	*** D 133	MJ60A0799	*** P3	*** B 138	MJ60A2751	*** P13	*** G 113
MF00A2780	*** P27	*** P 109	MH50A0739	*** P7	*** D 104	MJ60A0830	*** P3	*** B 142	MJ60A2758	*** P5	*** C 109
MF01A0181	*** P11	*** F 135	MH60T0497	*** P25	*** N 130	MJ60A0848	*** P15	*** H 101	MJ60A2770	*** P15	*** H 120
MF01E0411	*** P19	*** K 902	MJ60A0131	*** P29	*** Q 104	MJ60A0849	*** P3	*** B 147	MJ60A2780	*** P31	*** R 106
MF06A1620	*** P31	*** R 117	MJ60A0161	*** P3	*** B 139	MJ60A0851	*** P13	*** G 122	MJ60A2799	*** P7	*** D 135
MF10A0149	*** P31	*** R 112	MJ60A0220	*** P13	*** G 120	MJ60A0901	*** P15	*** H 118	MJ60A2848	*** P11	*** F 114
MF10A0325	*** P11	*** F 128	MJ60A0228	*** P21	*** L 109	MJ60A0910	*** P19	*** K 115	MJ60A2910	*** P7	*** D 115
MF10A0555	*** P13	*** G 128	MJ60A0230	*** P11	*** F 119	MJ60A0920	*** P21	*** L 135	MJ60A2920	*** P15	*** H 121
MF13E6456	*** P17	*** J 901	MJ60A0237	*** P7	*** D 112	MJ60A0982	*** P15	*** H 132	MJ60A3339	*** P3	*** B 112
MF20A0130	*** P29	*** Q 105	MJ60A0245	*** P13	*** G 130	MJ60A0983	*** P15	*** H 134	MJ60A3359	*** P23	*** M 126
MF21D0181	*** P11	*** F 133	MJ60A0262	*** P15	*** H 109	MJ60A1228	*** P21	*** L 101	MJ60A3429	*** P5	*** C 105
MG42A0181	*** P33	*** S 116	MJ60A0267	*** P15	*** H 105	MJ60A1245	*** P33	*** S 117	MJ60A3434	*** P23	*** M 113
MG43A0181	*** P9	*** E 148	MJ60A0339	*** P3	*** B 116	MJ60A1339	*** P3	*** B 101	MJ60A3476	*** P25	*** N 112
MG43A1181	*** P13	*** G 123	MJ60A0352	*** P21	*** L 111	MJ60A1359	*** P21	*** L 106	MJ60A3484	*** P21	*** L 144
MH10A0160	*** P31	*** R 103	MJ60A0359	*** P21	*** L 107	MJ60A1364	*** P17	*** J 106	MJ60A3508	*** P25	*** N 121
MH10A0181	*** P9	*** E 137	MJ60A0364	*** P11	*** F 113	↑	*** P21	*** L 127	MJ60A3571	*** P23	*** M 102
MH10A0267	*** P15	*** H 111	MJ60A0383	*** P11	*** F 120	MJ60A1416	*** P3	*** B 111	MJ60A3601	*** P25	*** N 116
MH10A0416	*** P11	*** F 108	MJ60A0413	*** P25	*** N 128	MJ60A1419	*** P31	*** R 113	MJ60A3742	*** P23	*** M 109
MH10A0417	*** P9	*** E 121	MJ60A0416	*** P3	*** B 105	MJ60A1420	*** P23	*** M 103	MJ60A3751	*** P15	*** H 107
MH10A0454	*** P11	*** F 105	MJ60A0420	*** P21	*** L 104	MJ60A1422	*** P3	*** B 121	MJ60A3780	*** P31	*** R 107
MH10A0572	*** P11	*** F 104	MJ60A0422	*** P15	*** H 131	MJ60A1426	*** P5	*** C 126	MJ60A3910	*** P15	*** H 143
MH10A0584	*** P9	*** E 134	MJ60A0426	*** P5	*** C 123	MJ60A1429	*** P5	*** C 112	MJ60A4339	*** P3	*** B 104
MH10A0602	*** P15	*** H 125	MJ60A0429	*** P5	*** C 115	MJ60A1434	*** P13	*** G 136	MJ60A4426	*** P21	*** L 123
↑	*** P19	*** K 124	MJ60A0434	*** P7	*** D 119	MJ60A1477	*** P21	*** L 133	MJ60A4429	*** P5	*** C 114
↑	*** P21	*** L 139	MJ60A0458	*** P21	*** L 105	MJ60A1484	*** P19	*** K 123	MJ60A4456	*** P13	*** G 131
↑	*** P23	*** M 121	MJ60A0471	*** P13	*** G 125	MJ60A1500	*** P3	*** B 134	MJ60A4476	*** P3	*** B 135
MH10A0626	*** P15	*** H 113	MJ60A0476	*** P23	*** M 134	MJ60A1508	*** P17	*** J 110	MJ60A4484	*** P23	*** M 122
MH10A0663	*** P11	*** F 129	MJ60A0477	*** P15	*** H 115	MJ60A1571	*** P25	*** N 129	MJ60A4508	*** P19	*** K 132

索引
INDEX-3

部品コード Parts No.	ページ Page	Fig No.	部品コード Parts No.	ページ Page	Fig No.	部品コード Parts No.	ページ Page	Fig No.	部品コード Parts No.	ページ Page	Fig No.
MJ60A4601	*** P23	*** M 118	MJ61A0450	*** P17	*** J 121	ML10A0555	*** P13	*** G 127			
MJ60A4770	*** P23	*** M 131	MJ61A0452	*** P17	*** J 115	MN10A0135	*** P27	*** P 105			
MJ60A4780	*** P21	*** L 116	MJ61A0454	*** P17	*** J 102	MN10A0477	*** P9	*** E 141			
MJ60A5339	*** P3	*** B 136	MJ61A0470	*** P5	*** C 102	MN10E0175	*** P9	*** E 145			
MJ60A5426	*** P29	*** Q 103	MJ61A0476	*** P9	*** E 103	MP10B0554	*** P9	*** E 139			
MJ60A5476	*** P21	*** L 118	MJ61A0516	*** P27	*** P 121	MP60A1187	*** P9	*** E 140			
MJ60A5484	*** P25	*** N 104	MJ61A0523	*** P17	*** J 105	MS01A0155	*** P11	*** F 126			
MJ60A5508	*** P19	*** K 131	MJ61A0567	*** P9	*** E 109	MS01A0329	*** P17	*** J 126			
MJ60A5601	*** P15	*** H 126	MJ61A0571	*** P9	*** E 113	MS01A0383	*** P11	*** F 903			
MJ60A5747	*** P23	*** M 106	MJ61A0601	*** P9	*** E 107	MS01A0572	*** P17	*** J 124			
MJ60A5770	*** P13	*** G 106	MJ61A0602	*** P9	*** E 119	MS01A0611	*** P17	*** J 129			
MJ60A6476	*** P21	*** L 128	MJ61A0628	*** P17	*** J 142	MS01A0660	*** P11	*** F 130			
MJ60A6508	*** P13	*** G 102	MJ61A0682	*** P17	*** J 137	MS01E0580	*** P11	*** F 904			
MJ60A6601	*** P21	*** L 140	MJ61A0688	*** P27	*** P 118	MS02A0128	*** P11	*** F 134			
MJ60A6770	*** P9	*** E 143	MJ61A0691	*** P27	*** P 120	↑	*** P31	*** R 108			
MJ60A7339	*** P3	*** B 126	MJ61A0722	*** P17	*** J 120	MS02A2456	*** P21	*** L 112			
MJ60A7508	*** P13	*** G 101	MJ61A0742	*** P5	*** C 104	MS03A0256	*** P33	*** S 110			
MJ60A8339	*** P3	*** B 131	MJ61A0757	*** P9	*** E 110	MS03A1256	*** P33	*** S 111			
MJ60A8508	*** P7	*** D 124	MJ61A0758	*** P9	*** E 104	MS06A0567	*** P31	*** R 126			
MJ60A8601	*** P7	*** D 121	MJ61A0760	*** P17	*** J 140	MS08A0616	*** P17	*** J 131			
MJ60A9339	*** P13	*** G 110	MJ61A0761	*** P17	*** J 117	MS09A0950	*** P17	*** J 128			
MJ60A9508	*** P11	*** F 115	MJ61A0767	*** P17	*** J 103	MS14A0682	*** P11	*** F 111			
MJ60A9601	*** P25	*** N 106	MJ61A0770	*** P9	*** E 108	MS14A1180	*** P9	*** E 125			
MJ60B0339	*** P13	*** G 112	MJ61A0887	*** P17	*** J 136	MS17A0125	*** P17	*** J 133			
MJ60B0508	*** P25	*** N 105	MJ61A0950	*** P19	*** K 116	MV30A0256	*** P15	*** H 112			
MJ60B0601	*** P31	*** R 105	MJ61A0975	*** P17	*** J 143	↑	*** P33	*** S 107			
MJ60B1508	*** P17	*** J 111	MJ61A1101	*** P19	*** K 102	MV30A1256	*** P33	*** S 108			
MJ60B1601	*** P3	*** B 125	↑	*** P33	*** S 102	MV35A0106	*** P33	*** S 106			
MJ60B2508	*** P23	*** M 110	MJ61A1339	*** P7	*** D 108						
MJ60B2601	*** P5	*** C 128	MJ61A1426	*** P27	*** P 117						
MJ60B3339	*** P3	*** B 133	MJ61A1476	*** P9	*** E 114						
MJ60B3508	*** P25	*** N 122	MJ61A1571	*** P17	*** J 134						
MJ60B4508	*** P21	*** L 119	MJ61A1601	*** P9	*** E 120						
MJ60B5339	*** P25	*** N 102	MJ61A1688	*** P27	*** P 119						
MJ60B5508	*** P21	*** L 120	MJ61A1742	*** P9	*** E 115						
MJ60B6508	*** P25	*** N 114	MJ61A1757	*** P9	*** E 117						
MJ60B7508	*** P25	*** N 117	MJ61A1758	*** P19	*** K 104						
MJ60B8508	*** P25	*** N 118	MJ61A1761	*** P17	*** J 139						
MJ60B9508	*** P25	*** N 110	MJ61A1767	*** P17	*** J 138						
MJ60C0508	*** P25	*** N 119	MJ61A1770	*** P9	*** E 111						
MJ60C1508	*** P21	*** L 126	MJ61A2101	*** P33	*** S 103						
MJ60C2508	*** P21	*** L 129	MJ61A2339	*** P9	*** E 102						
MJ60E0456	*** P11	*** F 901	MJ61A2601	*** P19	*** K 125						
MJ60E0599	*** P25	*** N 901	MJ61A2742	*** P17	*** J 150						
MJ60E0747	*** P21	*** L 901	MJ61A3101	*** P33	*** S 104						
MJ60E0991	*** P31	*** R 114	MJ61A3339	*** P17	*** J 152						
MJ60E1688	*** P27	*** P 106	MJ61A3742	*** P7	*** D 103						
MJ60E1747	*** P23	*** M 124	MJ61A4101	*** P33	*** S 105						
MJ61A0101	*** P33	*** S 101	MJ61A4339	*** P17	*** J 154						
MJ61A0121	*** P17	*** J 127	MJ61A5339	*** P19	*** K 129						
MJ61A0339	*** P7	*** D 107	MJ61A6339	*** P27	*** P 115						
MJ61A0383	*** P17	*** J 107	MJ61E0190	*** P9	*** E 901						
MJ61A0350	*** P19	*** K 118	MJ61E0352	*** P17	*** J 903						
MJ61A0422	*** P27	*** P 112	MJ61E0456	*** P17	*** J 902						
MJ61A0426	*** P27	*** P 116	MJ61E0472	*** P19	*** K 901						

三菱電機株式会社

お問い合わせは下記へどうぞ

FAシステム事業本部 機器計画部 駆動機器グループ 〒100-8310 東京都千代田区丸の内2-7-3(東京ビル)
代表電話番号 (03)3218-6631 代表FAX番号 (03)3218-6823

MITSUBISHI ELECTRIC CORPORATION

FACTORY AUTOMATION SYSTEM GROUP

Tokyo 100-8310, Japan

Fax : +81-3-3218-6821